



# SERVICE MANUAL

HF/VHF/UHF ALL MODE TRANSCEIVER  
**IC-706MKII**

---

---

---

---

S-14411XZ-C1  
June, 2007

Icom Inc.

---

## INTRODUCTION

This service manual describes the latest service information for the **IC-706MKIIG HF/VHF/UHF ALL MODE TRANSCEIVER** at the time of publication.

MODEL	VERSION	UT-106
IC-706MKIIG	USA	Available as an option
	EUR	
	FRA	
	ESP	
	OTH	
	ITA	
	ITR	
	CHN	
	USA-1	Built-in
	EUR-1	
	FRA-1	
	ESP-1	
	OTH-1	
	ITA-1	
	ITR-1	
	CHN-1	

## CAUTION

**NEVER** connect the transceiver to an AC outlet or to a DC power supply that uses more than 13.8 V. This will ruin the transceiver.

**DO NOT** expose the transceiver to rain, snow or any liquids.

**DO NOT** reverse the polarities of the power supply when connecting the transceiver.

**DO NOT** apply an RF signal of more than 20 dBm (100 mW) to the antenna connector. This could damage the transceiver's front-end.

To upgrade quality, any electrical or mechanical parts and internal circuits are subject to change without notice or obligation.



## ORDERING PARTS

Be sure to include the following four points when ordering replacement parts:

1. 10-digit Icom parts numbers
2. Component name
3. Equipment model name and unit name
4. Quantity required

### <ORDER EXAMPLE>

1110003491 S.IC TA31136FNG IC-706MKIIG MAIN UNIT 5 pieces  
8820001210 Screw 2438 screw IC-706MKIIG Top cover 10 pieces

Addresses are provided on the inside back cover for your convenience.

## REPAIR NOTES

1. Make sure the problem is internal before disassembling the transceiver.
2. **DO NOT** open the transceiver until the transceiver is disconnected from its power source.
3. **DO NOT** force any of the variable components. Turn them slowly and smoothly.
4. **DO NOT** short any circuits or electronic parts. An insulated tuning tool **MUST** be used for all adjustments.
5. **DO NOT** keep power ON for a long time when the transceiver is defective.
6. **DO NOT** transmit power into a Standard Signal Generator or a Sweep Generator.
7. **ALWAYS** connect a 50 dB to 60 dB attenuator between the transceiver and a Deviation Meter or Spectrum Analyzer when using such test equipment.
8. **READ** the instructions of test equipment thoroughly before connecting a test equipment to the transceiver.

---

## CONTENTS

---

**SECTION 1 SPECIFICATIONS**

**SECTION 2 INSIDE VIEWS**

**SECTION 3 CIRCUIT DESCRIPITON**

3-1	RECEIVER CIRCUITS.....	3-1
3-2	TRANSMITTER CIRCUITS.....	3-4
3-3	PLL CIRCUITS.....	3-6
3-4	LOGIC CIRCUITS.....	3-8

**SECTION 4 ADJUSTMENT PROCEDURES**

4-1	PREPARATION BEFORE SERVICING.....	4-1
4-2	PLL ADJUSTMENTS.....	4-2
4-3	TRANSMITTER ADJUSTMENTS.....	4-2
4-4	RECEIVER ADJUSTMENTS.....	4-8
4-4	SET MODE ADJUSTMENT.....	4-10

**SECTION 5 PARTS LIST**

**SECTION 6 MECHANICAL PARTS AND DISASSEMBLY**

**SECTION 7 SEMI-CONDUCTOR INFORMATION**

**SECTION 8 BOARD LAYOUTS**

**SECTION 9 BLOCK DIAGRAM**

**SECTION 10 VOLTAGE DIAGRAM**

	DISPALY AND VR BOARD'S.....	10-1
	MAIN UNIT AND HPF BOARD'S.....	10-2
	PLL UNIT.....	10-8
	FILTER BOARD.....	10-10
	PA UNIT AND DRIVER BOARD.....	10-11

# SECTION 1

# SPECIFICATIONS

## GENERAL

- Frequency coverage :
  - Receive 0.030 – 200.000 MHz\*
  - 430.000 – 470.000 MHz\*
  - Transmit 1.800 – 1.999 MHz\*
  - 3.500 – 3.999 MHz\*
  - 7.000 – 7.300 MHz\*
  - 10.100 – 10.150 MHz
  - 14.000 – 14.350 MHz
  - 18.068 – 18.168 MHz
  - 21.000 – 21.450 MHz
  - 24.890 – 24.990 MHz
  - 28.000 – 29.700 MHz
  - 50.000 – 54.000 MHz\*
  - 144.000 – 148.000 MHz\*
  - 430.000 – 450.000 MHz\*
- \*Depending on version.
- Mode : USB, LSB, CW, RTTY (FSK), AM, FM, WFM (WFM is for receiver only)
- Number of memory ch. : 107 (99 regular, 6 scan edges, 1 call)
- Antenna connector : SO-239 × 2  
(for HF/50 MHz and 144/440 MHz)/50 Ω
- Power supply requirement : 13.8 V DC ±15% (negative ground)
- Frequency stability : Less than ± 7 ppm from 1 min. to 60 min. after power ON. After that, rate of stability less than ±1 ppm/hr. at +25°C (+77°F). Temperature fluctuations 0°C to +50°C (+32°F to +122°F) less than ± 5 ppm.
- Current consumption :
  - Transmit max. power 20 A
  - Receive standby 1.8 A
  - max. audio 2.0 A
- Usable temperature range : -10°C to +60°C (+14°F to +140°F)
- Dimensions : 167(W) × 58(H) × 200(D) mm  
(projections not included) 6<sup>9</sup>/<sub>16</sub>(W) × 2<sup>9</sup>/<sub>32</sub>(H) × 7<sup>7</sup>/<sub>8</sub>(D) inch
- Weight : 2.45 kg (5 lb 6 oz)
- CI-V connector : 2-conductor 3.5 (d) mm (1/8")/8 Ω
- ACC connector : 13-pin

## TRANSMITTER

- Output power :
  - 1.8–50 MHz band SSB/CW/RTTY/FM 5–100 W
  - AM 2–40 W
  - 144 MHz band SSB/CW/RTTY/FM 5–50 W
  - AM 2–20 W
  - 440 MHz band SSB/CW/RTTY/FM 2–20 W
  - AM 2–8 W
- Modulation system :
  - SSB Balanced modulation
  - AM Low level modulation
  - FM Variable reactance modulation
- Spurious emissions :
  - Below 47.5 MHz Less than -50 dB (typical)
  - Above 47.5 MHz Less than -60 dB
- Carrier suppression : More than 40 dB
- Unwanted sideband supp. : More than 50 dB
- Microphone connector : 8-pin modular jack (600 Ω)
- KEY connector : 3-conductor 6.35 (d) mm (1/4")
- RTTY connector : 3-conductor 3.5 (d) mm (1/8")

## RECEIVER

- Receive system :
  - SSB/CW/AM/WFM Double superheterodyne
  - FM Triple superheterodyne

- Intermediate frequencies :

MODE	1st IF	2nd IF	3rd IF
SSB/AM-N/FM	69.0115 MHz	9.0115 MHz	455 kHz*
AM/FM-N	69.0100 MHz	9.0100 MHz	455 kHz*
CW	69.0106 MHz	9.0106 MHz	—
RTTY	69.0105 MHz	9.0105 MHz	—
WFM	70.7000 MHz	10.7000 MHz	—

\*FM or FM-N mode only

- Receive sensitivity : (pre-amp ON)

FREQUENCY	SSB/CW/RTTY	AM	FM
0.5 – 1.8 MHz	—	13 μV	—
1.8 – 28 MHz*	0.16 μV	2 μV	—
28 – 29.999 MHz	0.16 μV	2 μV	0.5 μV
50 MHz band	0.13 μV	1 μV	0.25 μV
144 MHz band	0.11 μV	1 μV	0.18 μV
440 MHz band	0.11 μV	1 μV	0.18 μV

Note: SSB, CW and AM modes are measured at 10 dB S/N; FM mode at 12 dB SINAD.

\*Except 4–4.5 MHz, 8–9 MHz.

- Squelch Sensitivity : (pre-amp ON)
  - SSB Less than 5.6 μV
  - FM Less than 0.32 μV
- Selectivity\* :
  - SSB, CW, RTTY More than 2.4 kHz/-6 dB
  - Less than 4.8 kHz/-60 dB
  - AM/FM-N More than 8.0 kHz/-6 dB
  - Less than 30 kHz/-40 dB
  - FM More than 12 kHz/-6 dB
  - Less than 30 kHz/-60 dB
- \*Without an optional filter unit and with mid bandwidth selected.
- Spurious and image rejection ratio:
  - HF band 70dB
  - 50 MHz band 65 dB (except IF through)
  - 144/440 MHz band 65 dB
- Audio output power : More than 2.0 W at 10% distortion  
(at 13.8 V DC)
- RIT variable range : ± 9.99 kHz
- PHONES connector : 3-conductor 3.5 (d) mm (1/8")/8 Ω
- EXT SP connector : 2-conductor 3.5 (d) mm (1/8")/8 Ω

All stated specifications are subject to change without notice or obligation.



# SECTION 2

# INSIDE VIEWS

## • MAIN AND FILTER BOARDS

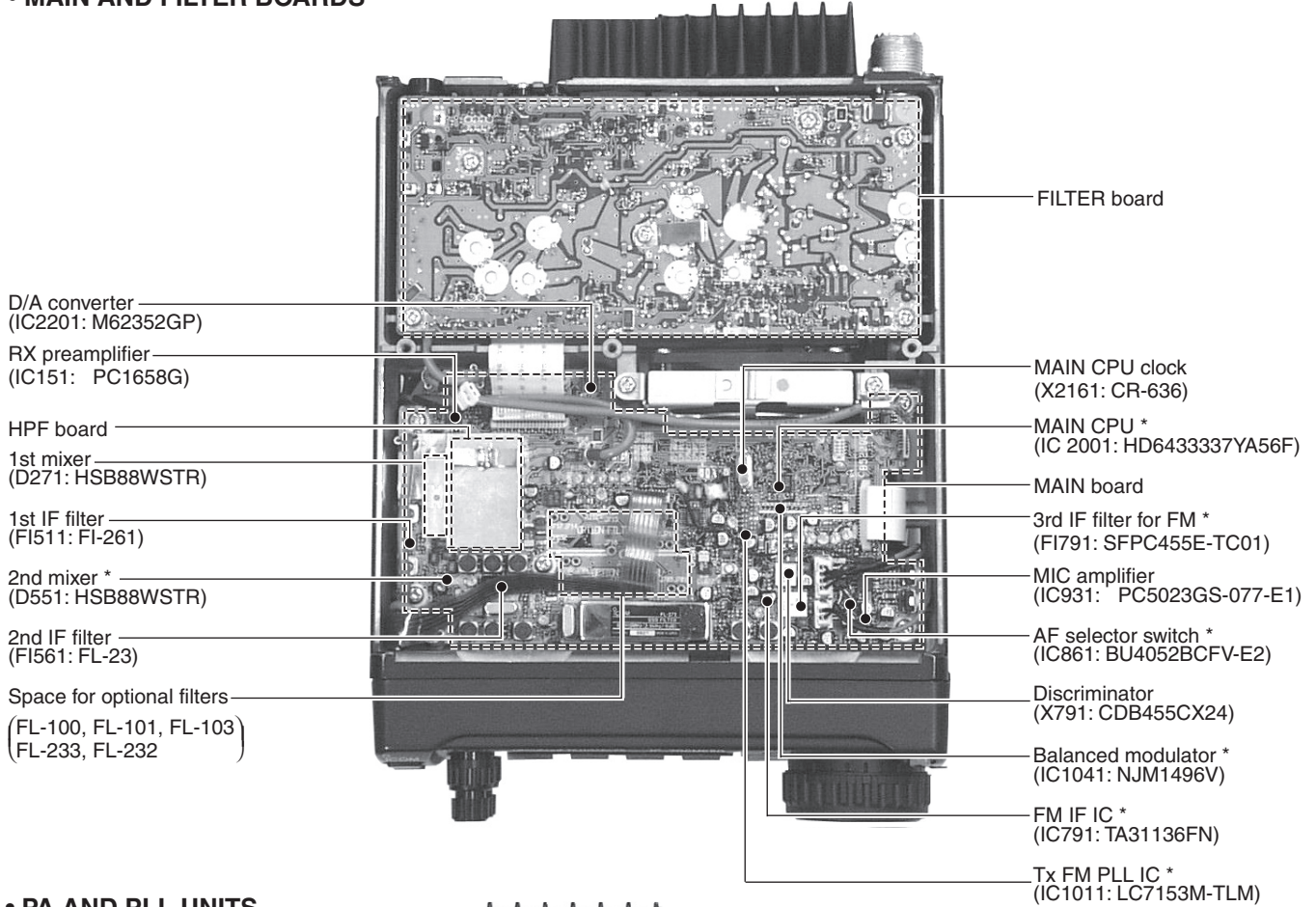

## • PA AND PLL UNITS

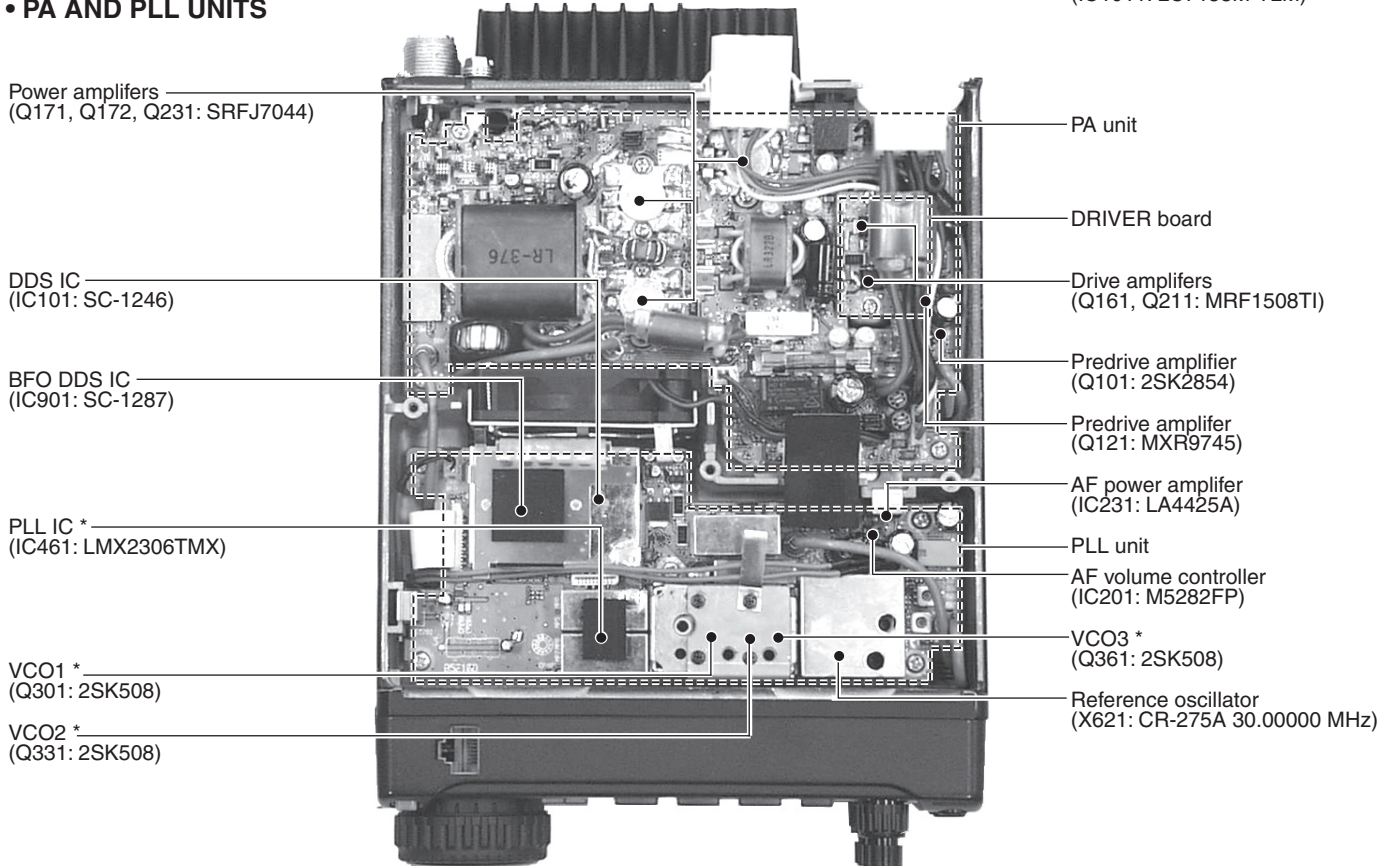

\*Located under side of the point

## 3-1 RECEIVER CIRCUITS

### 3-1-1 HF/50 MHz RF CIRCUIT

#### (FILTER, MAIN AND HPF BOARDS)

HF/50 MHz RF filters pass only the desired band signals and suppress any undesired band signals. The HF/50 MHz RF circuit has 7 low-pass filters and 8 high-pass filters for specified band use.

HF/50 MHz RF signals from the [ANT1] connector, pass through one of 7 low-pass filters as below, the transmit/receive switching relay (FILTER board; RL1) and low-pass filter (FILTER board; L1, L2, C1–C5), and are then applied to the MAIN board via J1 (FILTER board).

#### • Used RF low-pass filter (FILTER board)

Frequency (MHz)	Control signal	Entrance coil	Frequency (MHz)	Control signal	Entrance coil
0.03–2 MHz	L1	RL15	15–22 MHz	L5	RL11
2–4 MHz	L2	RL13	22–30 MHz	L6	RL7
4–8 MHz	L3	RL5	30–60 MHz	L7	RL3
8–15 MHz	L4	RL9			

The signals from the FILTER board are applied to or bypass the 20 dB attenuator (R122, R125, R126). The signals pass through the high-pass filter (L132, L133, C132–C137) to suppress strong signals below 1.6 MHz and are then applied to the HPF board via the “SAF” terminal.

#### (1) 0.03–2 MHz and 30–40 MHz

The signals pass through a low-pass filter (L101, L102, C101–C105), and then applied to the preamplifier circuit on the MAIN board.

#### (2) 2–30 MHz

The signals from the low-pass filter (L101, L102, C101–C105) are applied to one of 6 high-pass filters as at right above and are then applied to the preamplifier circuit on the MAIN board.

#### (3) 40–60 MHz

The signals pass through the low-pass filter (L172, L173, C172–C176) and the high-pass filter (L174, L175, C177–C181) via D171 and are then applied to the preamplifier circuit on the MAIN board.

#### • Used RF high-pass filter (HPF board)

Frequency (MHz)	Control signal	Entrance coil	Frequency (MHz)	Control signal	Entrance coil
0.03–2 MHz	THH	D111	15–22 MHz	L5H	D151
2–4 MHz	L2H	D121	22–30 MHz	L6H	D161
4–8 MHz	L3H	D131	30–40 MHz	THH	D111
8–15 MHz	L4H	D141	40–60 MHz	B7H	D171

### 3-1-2 VHF AND UHF RF CIRCUITS (PA UNIT)

The VHF and UHF RF circuits pass and amplify only the desired band signals and suppresses any undesired band signals. The both RF circuits have a preamplifier and band-pass filters respectively.

#### • VHF RF CIRCUIT

The VHF RF signals from the [ANT2] connector pass through the low-pass filter (L263–L265, C274–C276) and antenna switching circuit (D291–D293). The signals are applied to the bandpass filter (D403, D409, D408), and are then amplified at the preamplifier circuit (Q403). The amplified signals are then applied to the another bandpass filter (D407, D406, D410).

#### • UHF RF CIRCUIT

The UHF RF signals from the [ANT2] connector pass through the high-pass filter (L316, L317, C326–C327), low-pass filter (L313–L315, C322–C324) and antenna switching circuit (D341, D342, D343). The signals are amplified at the preamplifier circuit (Q453) between the 2 bandpass filters (D454, D453 and D454, D456).

The filtered signals are applied to the MAIN board via J481 (PA unit) and are then applied to the preamplifier circuit.

D403, D408, D409, D406, D407, D410, D454, D453, D454 and D456 are varactor diodes that tune the center frequency of an RF passband for wide bandwidth receiving and good image response rejection. On the VHF band, receiving signals are above 129 MHz, the switching diodes (D404, D405) are turned off by the control signal “2MBL” from PLL unit, then the varactor diodes (D408, D407) are disconnected.

## • RECEIVER CONSTRUCTION

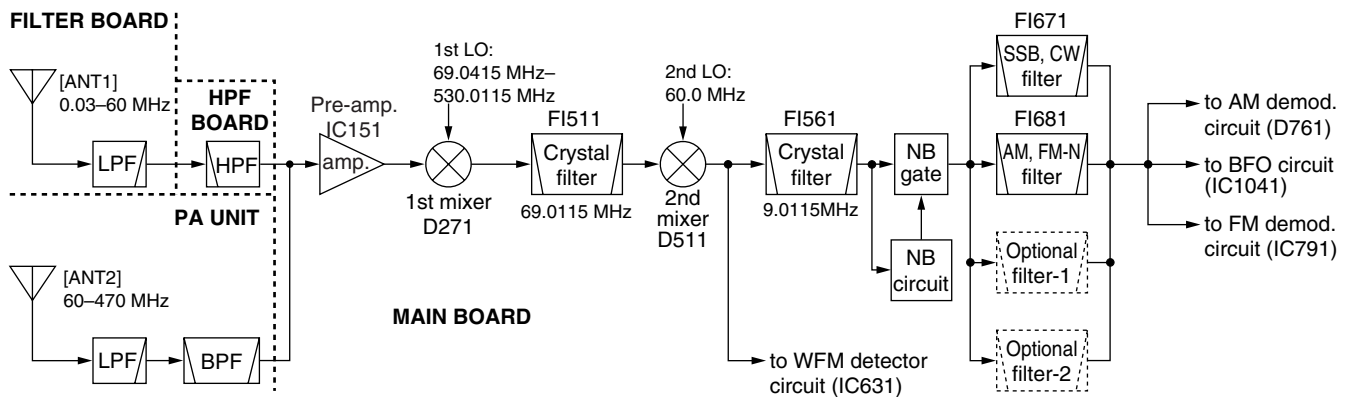

### 3-1-3 PREAMPLIFIER CIRCUIT (MAIN BOARD)

The preamplifier circuit in the IC-706MKIIG has approx. 15dB gain over a wide-band frequency range.

When the preamplifier is turned ON, the signals from the RF circuit are applied to the preamplifier (IC151) via D2182. Amplified or bypassed signals are applied to the 1st mixer circuit (D271).

### 3-1-4 1ST MIXER CIRCUIT (MAIN BOARD)

The 1st mixer circuit mixes the receive signals with the 1st LO signal to convert the receive signal frequencies to a 69 or 70.7 MHz 1st IF signal.

The signals from the preamplifier circuit, or signals which bypass the preamplifier, are passed through a low-pass filter and then applied to the 1st mixer (D271).

The 1st LO signals (69.0415–539.0115 MHz) enter the MAIN board from the PLL unit via J281. The LO signal is amplified at IC281, filtered by a low-pass filter, and then, applied to the 1st mixer.

#### • 1st IF frequency

Mode	1st IF
SSB/AM-N/FM	69.0115 MHz
AM/FM-N	69.0100 MHz
CW	69.0106 MHz
RTTY	69.0105 MHz
WFM	70.7000 MHz

### 3-1-5 1ST IF CIRCUIT (MAIN BOARD)

The 1st IF circuit filters and amplifies the 1st IF signals. The 1st IF signals are applied to a Crystal Filter (FI511) to suppress out-of-band signals.

The 69 MHz 1st IF signals (except WFM) pass through the crystal filter (FI511), however, the 70.7 MHz 1st IF signal (WFM) passes through a bandpass filter (L501–L505, C501–C506). Then the filtered signals are applied to the IF amplifier (IC521).

The AGC voltage is supplied to the transmit/receive switching circuit (D521, D522) and D521/D522 function as PIN attenuators for AGC operation.

The amplified signals are then applied to the 2nd mixer circuit (D551) via the bandpass filter (L542–L546, C542–C545).

### 3-1-6 2ND MIXER CIRCUIT (MAIN BOARD)

The 2nd mixer circuit mixes the 1st IF signals and 2nd LO signal (60.00 MHz) to convert the 1st IF to a 2nd IF.

The 1st IF signals from the band pass filter (L542–L546, C542–C545) are converted to 9 MHz or 10.7 MHz 2nd IF signals at the 2nd mixer (D551).

The 2nd IF signals are applied to the bandpass filter (FI561) to suppress undesired signals, such as the 2nd LO signal, and are then applied to the noise blanker gate (D561, D562).

#### • 2nd IF frequency

Mode	2nd IF
SSB/AM-N/FM	9.0115 MHz
AM/FM-N	9.0100 MHz
CW	9.0106 MHz
RTTY	9.0105 MHz
WFM	10.7000 MHz

While in WFM mode, the IF signals pass through the low-pass filter (L601, C601–C603), IF amplifiers (Q601, Q611), ceramic filter (FI611). The signals are then applied to the WFM demodulator circuit (IC631).

### 3-1-7 NOISE BLANKER CIRCUIT (MAIN BOARD)

The noise blanker circuit detects pulse type noise, and turns OFF the signal line when noise appears.

A portion of the signals from FI561 are amplified at the noise amplifiers (Q621, Q632, amplifier section of IC631), then detected at the noise detector (D632) to convert the noise components to DC voltages.

The converted voltages are then applied to the noise blanker switch (Q634, Q635). At the moment the detected voltage exceeds Q634's threshold level, Q635 outputs a blanking signal to close the noise blanker gate (D561, D562) by applying reverse-biased voltage.

The detected voltage from D632 is also applied to the noise blanker AGC circuit (Q631, Q633) and is then fed back to the noise amplifier (IC631) as a bias voltage. The noise AGC circuit prevents closure of the noise blanker gate for long periods by non-pulse-type noise. The time constant of the noise blanker AGC circuit is determined by R637.

The 2nd IF signals from the noise blanker gate are then applied to the 2nd IF circuit.

### 3-1-8 2ND IF CIRCUIT

The 2nd IF circuit amplifies and filters the 2nd IF signals.

The 2nd IF signals from the noise blanker gate (D561, D562) are amplified at the IF amplifier (IC571) via the Tx/Rx switch (D572) and applied to a 2nd IF filter as shown below.

The filtered or bypassed signals are applied to the buffer amplifier (Q721), IF amplifiers (Q731, Q741) and buffer amplifier (Q751) to obtain a detectable level at the demodulator circuit

#### • Used 2nd IF filter

Mode	Used filter	Control signal
SSB, CW, RTTY AM nar.	FL-272 (FI671)	2F23
AM, FM nar.	FL-94 (FI681)	2F80
FM	Bypassed	2FTH
SSB nar.	Optional FL-223	OP1 or OP2
CW nar., RTTY nar.	Optional FL-100, FL101, FL-223, FL-232	OP1 or OP2
SSB wide, CW wide, RTTY wide	Optional FL-103	OP1 or OP2

The amplified signals from the buffer amplifier (Q751) are shared between the SSB/CW/RTTY detector (IC841), AM detector (D761) and AGC detector (D771). Output signals from the buffer amplifier (Q721) are applied to the FM IF IC (IC791).





### 3-1-14 AF SELECTOR SWITCH (MAIN BOARD)

The AF signals from one of the detector circuits are applied to the AF selector switch (IC861). IC861 consists of dual 4-channel analog switches which are selected with a mode signal and the squelch control signal.

#### • AF selector switch

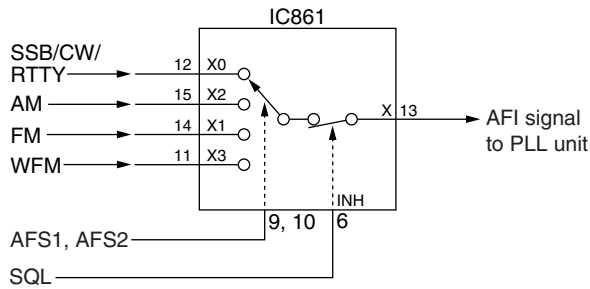

### 3-1-15 AF AMPLIFIER CIRCUIT (PLL UNIT)

The AF amplifier amplifies the demodulated signal to a suitable driving level for the speaker.

The AF signals from the AF selector switch (MAIN board; IC861) are applied to the PLL unit via the "AFI" signal line. The CW side tone/beep tone and optional synthesized voice are also applied to the PLL unit via the "AFBP" signal line.

The AF signals from the MAIN board are applied to the VCA (Voltage Controlled Amplifier) circuit (IC201). The AF gain setting from the main CPU is converted to DC voltage at the D/A converter (MAIN board IC2201) and applied to the VCA control terminal (IC201, pin 8) via the "AFGC" signal line. The output AF signal from IC201 (pin 9) is power-amplified at IC231 to drive the speaker.

## 3-2 TRANSMITTER CIRCUITS

### 3-2-1 MICROPHONE AMPLIFIER CIRCUIT (MAIN BOARD)

The microphone amplifier circuit amplifies microphone input signals and outputs the amplified signals to the balanced modulator or FM modulation circuit.

#### • Microphone amplifier

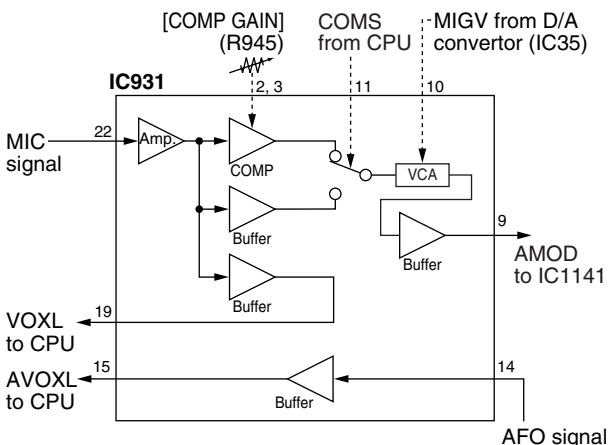

Audio signals from the front or rear panel [MIC] connector enter the microphone amplifier IC (IC931, pin 22) and are then amplified at the microphone amplifier or speech compressor section. Compression level is adjusted with the [COMP GAIN] control (R945).

The amplified or compressed signals are applied to the VCA section of IC931. The microphone gain setting from the D/A converter (IC2201, pin 2) is applied to the VCA control terminal (IC931, pin 10). The resulting signals from pin 9 are then applied to the buffer amplifier (Q961) via the analog switch (IC1141). External modulation input from the [ACC] socket (pin 11) is also applied to Q961.

While in SSB mode, the amplified signals from the buffer amplifier (Q961) are passed through the AF selector switch (IC971) and are then applied to the balanced modulator (IC1041).

While in AM/FM mode, the amplified signals from the buffer amplifier (Q961) are applied to the limiter amplifier (IC981a) and splatter filter (IC981b). The signals are then applied to the AF selector switch (IC971) in AM mode or to the varactor diode (D1012) in FM mode.

### 3-2-2 VOX CIRCUIT (MAIN BOARD)

The VOX (Voice-Operated-Transmission) circuit sets transmitting conditions according to voice input.

When the VOX function is activated, the microphone signals from IC931 (pin 19) are applied to the VOX comparator section in the main CPU (IC2001, pin 32) via the VOXL line.

A portion of the power amplified AF signals from the AF power amplifier (PLL unit; IC231) are amplified at the buffer amplifier (IC931, pins 14, 15) and applied to the anti-VOX comparator section in the main CPU (IC2001, pin 33) via the AVXL line.

Then the main CPU compares these and controls the transmitter circuit.

### 3-2-3 BALANCED MODULATOR (MAIN BOARD)

The balanced modulator converts the AF signals from the microphone amplifier to a 9 MHz IF signal with a BFO (Beat Frequency Oscillator) signal.

Microphone signals from the AF selector switch (IC971) are applied to the balanced modulator (IC1041, pin 1). The BFO signal from the PLL unit is applied to IC1041 (pin 10) as a carrier signal.

IC1041 is a double balanced mixer IC and outputs a double side band (DSB) signal with -40 dB of carrier suppression. R1045 adjusts the balanced level of IC1041 for maximum carrier suppression. The resulting signal passes through a 9 MHz IF filter (FI671 in SSB/CW/RTTY modes) to suppress unwanted side-band signals.

In AM mode, R1042 is connected to upset the balance of IC1041 via Q1041 for leaking the BFO signal as a carrier signal. The CW keying/RTTY TX signal is applied to IC1041 pin 1.

### 3-2-4 FM MODULATION CIRCUIT (MAIN BOARD)

The microphone signals from Q961 are applied to the limiter amplifier (IC981a) and the splatter filter (IC981b). The 1750 Hz European tone signal from the main CPU (IC2001 pin 40) is also applied to IC981a pin 2 for European repeaters. The sub-audible tone signal (67.0–254.1 Hz) from the main CPU (IC2001 pin 37) is also applied to IC981b pin 5 for repeater use.

The resulting signals are applied to the VCO circuit (Q1011, D1012) via R1002 to change the reactance of the varactor diode (D1012) for FM modulation. The modulated signal is amplified at the buffer amplifier (Q1013) and bypasses the 9 MHz IF filter.

### 3-2-5 TRANSMITTER IF CIRCUIT (MAIN BOARD)

The 9 MHz IF signal from the modulation circuit passes through the 9 MHz IF filter (FI671 in SSB/CW/RTTY modes; FI681 in AM/FM-N modes; through in FM mode). The signal is amplified at IC571, and then passes through the total gain adjustment volume (R579), and the crystal filter (FI561). The signal is then applied to the 2nd mixer (D551).

The signal is mixed with the 2nd LO signal (60 MHz) and converted to a 69 MHz IF signal at the 2nd mixer (D551). The 69 MHz IF signal passes through a bandpass filter, IF amplifier (IC521) and 69 MHz IF filter (FI511), and is then converted to the displayed frequency at the 1st mixer (D271) with the 1st LO signal. The mixers (D271, D551) and IF amplifiers (IC521, IC571) are used commonly for both receiving and transmitting.

The ALC voltage is supplied to the transmit/receive switching circuit (D521/D522 and D572/D573). D521/D522 and D572/D573 function as PIN attenuators for ALC operation.

### 3-2-6 RF CIRCUIT (PA UNIT, MAIN AND HPF BOARD)

The RF circuit amplifies the displayed frequency signal to obtain 100 W of RF output power for HF/50 MHz bands and 50 W for the 144 MHz band, 20 W for the 440 MHz band.

The HF/50 MHz RF signals from the 1st mixer (D271) via the low-pass filter enter the HPF board and then pass through one of 8 high-pass filters (Refer to 3-1 for used RF high-pass filter). The 50 MHz RF signals pass through a low-pass filter additionally. The filtered signals return to the MAIN board, are amplified at the YGR amplifier (IC231), and are then applied to the PA unit.

### • TRANSMITTER CONSTRUCTION

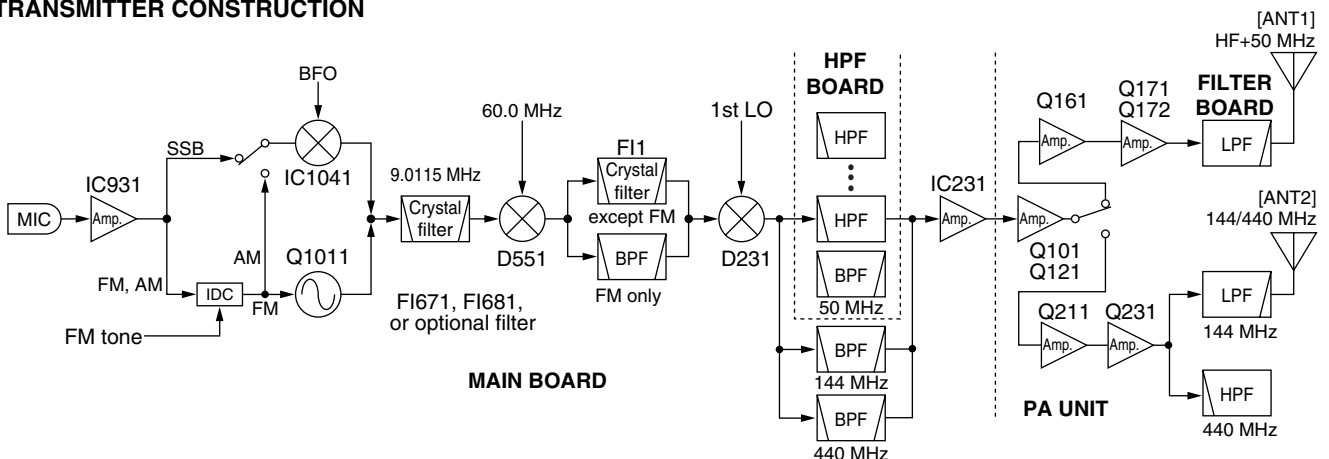

The 144 MHz RF signals from the 1st mixer (D271) via the low-pass filter (L251–253, C253–259) bypass the filters and pass through the bandpass filter (L182–L184, L195, L196, C181–C186, C195–C197) in the MAIN board. The signals are amplified at the RF amplifier (IC221) and YGR amplifier (IC231) and are then applied to the PA unit.

The 440 MHz RF signals from the 1st mixer (D271) via the low-pass filter (L251–253, C253–259) are amplified at RF amplifier (IC222) and passed through the bandpass filter (FI371–FI373) in the MAIN board. The filtered signal is amplified at the YGR amplifier (IC231) and is applied to the PA unit.

The signals from IC231 enter the PA unit and is amplified at the drive amplifiers (Q101, Q121) in sequence. The amplified signals are applied to the band switch (RL1).

The HF/50 MHz RF signals from the band switch (RL1) are amplified at the drive (DRIVER board; Q161) and power (Q171, Q172) amplifiers to obtain a stable 100 W of RF output power. The power-amplified signals are then applied to the [ANT1] connector via one of the 7 low-pass filters in the FILTER board.

For the 144/440 MHz RF signals from the band switch (RL1), 50 W for 144 MHz band or 20 W for 440 MHz band of RF output power is obtained at the drive (DRIVER board; Q211) and power amplifier (Q231). The power-amplified signals are applied to the [ANT2] connector via the antenna switching circuit and low-pass (144 MHz band) or high pass (440 MHz band) filters.

### 3-2-7 ALC CIRCUIT (MAIN BOARD)

The ALC (Automatic Level Control) circuit reduces the gain of IF amplifiers in order for the transceiver to output a constant RF power set by the RF power setting even when the supplied voltage shifts, etc.

The HF/50 MHz RF power signal level is detected at the power detector (FILTER board; D9), buffer-amplified at IC1b and applied to the MAIN board as the “HFOR” voltage.

The 144 MHz and 440 MHz RF power signals are detected at the power detectors (PA unit; D262, D263) and (PA unit; D312, D313) respectively. The detected signals are applied to the MAIN board as the “VFOR” or “UFOR” voltages.

The “FOR”, “VFOR” and “UFOR” voltages are combined to the “FORL” voltage and then applied to IC1091b (pin 6). The “POCV” voltage from the D/A converter (IC2201, pin 3), determined by the RF power setting, is applied to IC1091b (pin 5) as the reference voltage.

When the “FORL” voltage exceeds the “POCV” voltage, ALC bias voltage from IC1091a (pin 1) controls the PIN diodes (D521, D522, D572, D573) using Q1092. This adjusts the output power to the level determined by the RF power setting until the “FORL” and “POCV” voltages are equalized.

In AM mode, IC1091a operates as an averaging ALC amplifier with Q1091 and C1091. Q1071 turns ON and the “POCV” voltage is shifted for 40 W AM output power (maximum, 20 W for 144 MHz band, 8 W for 440 MHz band) through R1080.

The ALC bias voltage from IC1091a is also applied to the main CPU (IC2001 pin 34) as the “ALCL” voltage for ALC meter indication.

An external ALC input (minus voltage) from the [ACC] socket (pin 6) is shifted to plus voltage at D1131 and is applied to the buffer amplifier (Q1131). External ALC operation is identical to that of the internal ALC.

### 3-2-8 APC CIRCUIT (MAIN BOARD)

The APC (Automatic Power Control) circuit protects the power amplifiers on the PA unit from high SWR and excessive current for the HF/50 MHz band.

The reflected wave signal appears and increases on the antenna connector when the antenna is mismatched. The HF/50 MHz reflected signal level is detected at D10 (FILTER board), and is amplified at the APC amplifier (IC1091c) and applied to the ALC circuit as the reference voltage.

For the current APC, the driving current at the power amplifier is detected in the voltages (“ICH” and “ICL”) which appear at both terminals of a 0.012  $\Omega$  resistor (R201) on the PA unit. The detected voltages are applied to the differential amplifier (IC1091d, pins 13, 12). When the current of the power amplifier exceeds 22 A, IC1091d controls the ALC line via IC1091a to prevent excessive current flow.

### 3-2-9 RF, ALC, SWR METER CIRCUITS (MAIN BOARD)

While transmitting, RF, ALC or SWR meter readings are available and can be selected with the [MET] switch.

#### (1) Power meter

The “FOR”, “VFOR” and “UFOR” voltages are combined to the “FORL” voltage, and it is then applied to the main CPU (IC2001, pin 35) via the analog switch (IC2101, pins 11, 13) for indicating the output power.

#### (2) ALC meter

The ALC bias voltage from IC1091a pin 1 is applied to the main CPU (IC2001, pin 34) via the “ALCV” signal line for indicating the ALC level.

#### (3) SWR meter

The “FORL” and “REFL” voltages are applied to the main CPU (IC2001, pins 32 and 36) via the analog switch (IC2101, pins 11, 13 and 4, 3) respectively. The main CPU compares the ratio of “FORV” to “REFV” voltage and indicates the SWR for the [ANT1] connector.

## 3-3 PLL CIRCUITS

### 3-3-1 GENERAL

The PLL unit generates a 1st LO frequency (69.0415–530.0115 MHz), a 2nd LO frequency (60 MHz), a BFO frequency (9.01 MHz), an FM 3rd LO frequency (9.4665/9.4650 MHz) and a TX FM PLL reference frequency (9.0115/9.0100 MHz).

The 1st LO PLL adopts a mixer-less dual loop PLL system and has 3 VCO circuits. The BFO uses a DDS and the 2nd LO uses a fixed frequency double that of the crystal oscillator.

### 3-3-2 1ST LO PLL CIRCUIT

The 1st LO PLL contains a main loop and reference loop forming a dual loop system.

The reference loop generates a 10.6605 to 10.683 MHz frequency using a DDS circuit, and the main loop generates a 69.0415 to 269.50575 MHz frequency using the reference loop frequency.

While operating on 60 MHz and above, the output is doubled at D531 for oscillating a wide frequency range.

#### (1) REFERENCE LOOP PLL

The oscillated signal at the reference VCO (Q1, D1) is amplified at the amplifiers (Q21, Q51) and is then applied to the DDS IC (IC101, pin 46). The signal is then divided and detected on phase with the DDS generated frequency.

The detected signals output from IC101 (pin 56) is converted into a DC voltage (lock voltage) at the loop filter (R133, R134, C133) and then fed back to the varactor diode (D1) in the VCO circuit.

#### (2) MAIN LOOP PLL

The oscillated signal at one of the main loop VCOs (Q301, Q331, Q361) is amplified at the buffer amplifiers (Q10) and is then applied to the PLL IC (IC461, pin 6). The signal is then divided and detected on phase with the reference loop output frequency.

The detected signal output from the PLL IC (IC461, pin 2) is converted into a DC voltage (lock voltage) at the active loop filter and then fed back to one of the varactor diodes (D301, D331, D361) in the VCO circuits. While operating on 60 MHz and above, the VCO output is doubled at the doubler circuit (D531) and amplified at the amplifier (IC541).

The oscillated signal passes through a low-pass or band-pass filter and is then applied to the MAIN board as a 1st LO signal.

### 3-3-3 2ND LO AND REFERENCE OSCILLATOR CIRCUITS

The reference oscillator (X621, Q621) generates a 30.0 MHz frequency used for the 1st LO and BFO circuits as a system clock and for the 2nd LO signal.

The oscillated signal is amplified at the buffer amplifier (Q661), and is doubled at Q681 and the 60 MHz frequency is picked up at the bandpass filter (L681, L682). The 60 MHz signal is applied to the MAIN board as a 2nd LO signal.

### 3-3-4 BFO CIRCUIT

The DDS IC (IC901) generates a 10-bit digital signal. The signal is converted into an analog wave signal at the D/A converter (R951–R970). The analog wave is passed through the high-pass filter and low-pass filter. The 9 MHz BFO signal is then applied to the MAIN board via the “BFO” signal line.

While transmitting in RTTY mode, the RTTY keying signal is applied to IC901 pin 3 to shift the generated frequency and to obtain 2 frequencies for FSK operation.

While receiving in FM or FM narrow mode, the BFO circuit generates a 9.4665 MHz frequency as the 3rd LO signal.

While transmitting in FM or FM narrow mode, the BFO circuit generates a 9.0115 MHz or 9.0100 MHz frequency as the TX FM PLL reference frequency, respectively.

### • FREQUENCY CONSTRUCTION

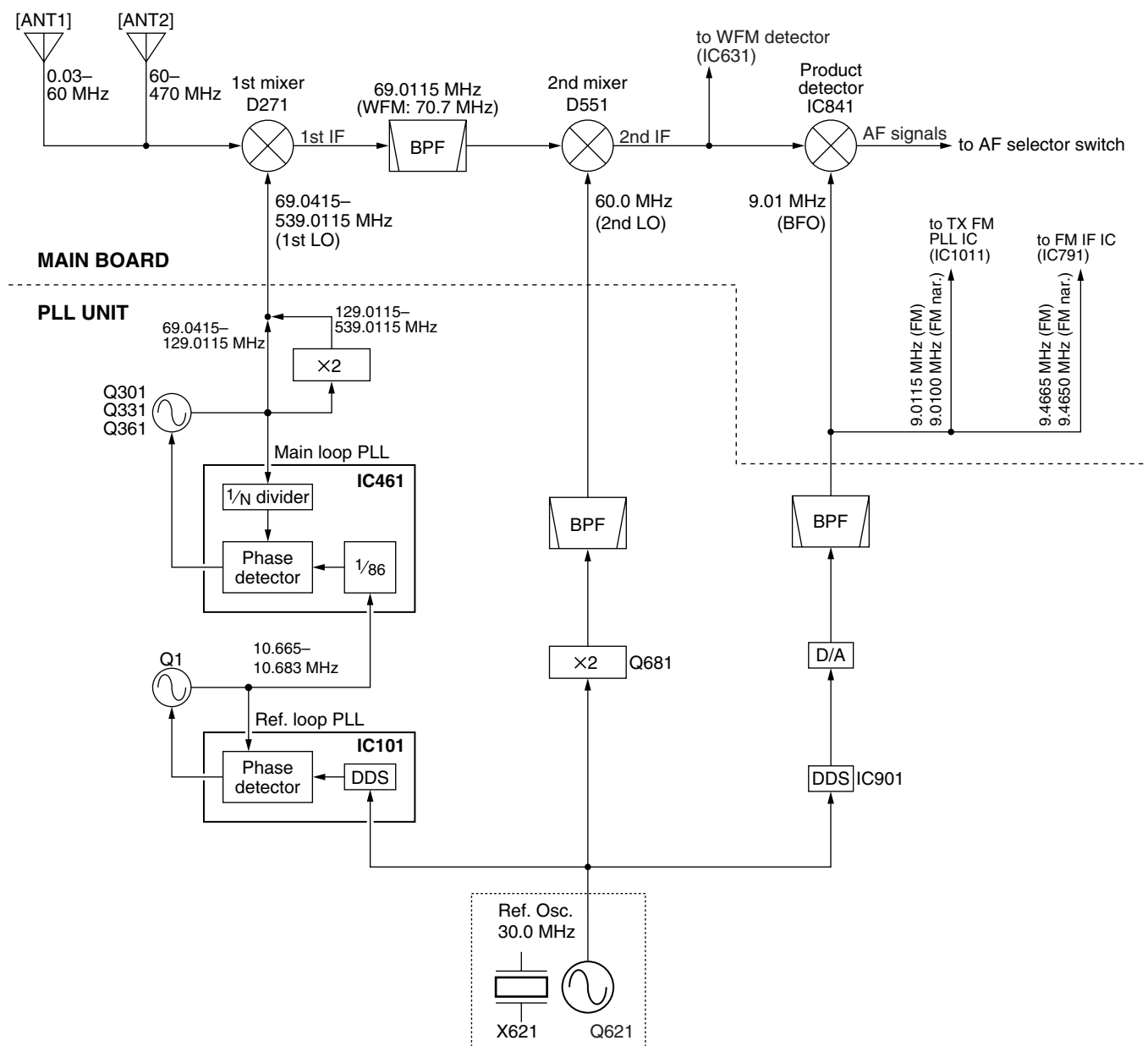



• BFO frequency

Mode	RX BFO/3rd LO frequency [MHz]	TX BFO/FM PLL ref. frequency [MHz]
USB	9.0130	9.0130
LSB	9.0100	9.0100
CW	9.0106 (-CW pitch frequency)	9.0106 (-CW pitch frequency)
CW-R	9.0106 (+CW pitch frequency)	9.0106 (+CW pitch frequency)
RTTY	9.008375 (2125 Hz tone) 9.008885 (1615 Hz tone)	9.0105 (MARK)
AM	No output	9.0100
FM	9.4665 (3rd LO)	9.0115 (PLL ref.)
FM nar.	9.4650 (3rd LO)	9.0100 (PLL ref.)
WFM	No output	No output

IF shift: Center, RTTY: Normal polarity

### 3-4 LOGIC CIRCUITS

#### 3-4-1 BAND SELECTION DATA (MAIN BOARD AND PLL UNIT)

To select the correct RF low-pass filter, high-pass filter and VCOs on the PLL unit, the CPU outputs the following band selection data from the I/O expander (MAIN board; IC2231, IC2232), the D/A converter (MAIN board; IC2201) or DDS IC (PLL unit; IC101) depending on the display frequency.

The D/A convertor output from IC2201 (pin 18) is doubled at IC891d to obtain the band voltage for external equipment.

• Band selection data

Frequency [MHz]	IC2231, IC2232 (MAIN)		IC2201 (MAIN)	IC101 (PLL)	
	HPF BPF	LPF LPF	1/2 band voltage	VCO	LPF BPF
0.03– 1.999999	L1	L1	3.70 V	VCO1	LOF1
2.0– 3.999999	L2	L2	3.19 V		
4.0– 7.999999	L3	L3	2.68 V		
8.0– 10.999999	L4	L4	0 V		
11.0– 14.999999			2.18 V		
15.0– 21.999999	L5	L5	1.69 V		
22.0– 29.999999	L6	L6	1.19 V		
30.0– 39.999999	B7W	L7	0.96 V	VCO2	LOF2
40.0– 59.999999	B7				
60.0–128.999999	B8	L8		VCO1	LOF3
129.0–143.999999				VCO2	LOF4
144.0–148.000000				VCO2	LOF5
148.000001–199.999999				VCO2	LOF4
400.000000–470.000000	B9	B9	VCO3	LOF6	

#### 3-4-2 SUB CPU PORT ALLOCATIONS (DISPLAY board; IC1)

Pin number	Port name	Description
1	SFTL	Input port for the [SHIFT] control.
18	PTTS	Outputs a PTT signal. Low : While transmitting.
19, 20	BU1S, BU2S	Outputs display backlight control signal.
80	PHNK	Input port for the [PHONES] jack connection detection. High : When the headphone or external speaker is connected to the [PHONES] jack.
81	RSK	Input port for the [RIT] switch.
96	PTTL	Input port for the [PTT] switch on the microphone.
97	FUDL	Input port for the microphone up/down signal.
98	AFGL	Input port for the [AF] control.
99	SQLL	Input port for the [RF/SQL] control.

#### 3-4-3 I/O EXPANDER PORT ALLOCATIONS (MAIN board; IC2221)

Pin number	Port name	Description																			
4	MODS	Outputs select signal for the Tx AF selector switch (IC1141). High : When AM and SSB modes are selected.																			
5	AMS	Outputs AM mode select signal. High : When AM mode is selected.																			
6	FMS	Outputs FM and FM-N modes select signal. High : When FM and FM-N modes are selected.																			
7	WFMS	Outputs WFM mode select signal. High : When WFM mode is selected.																			
11, 12	AFS1, AFS2	Output select signals for the Rx AF selector switch (IC861). <table border="1" style="margin-left: 20px;"> <thead> <tr> <th rowspan="2">PORT</th> <th colspan="4">MODE</th> </tr> <tr> <th>WFM</th> <th>FM</th> <th>AM</th> <th>SSB/CW/RTTY</th> </tr> </thead> <tbody> <tr> <td>AFS1</td> <td>High</td> <td>High</td> <td>Low</td> <td>Low</td> </tr> <tr> <td>AFS2</td> <td>High</td> <td>High</td> <td>Low</td> <td>Low</td> </tr> </tbody> </table>	PORT	MODE				WFM	FM	AM	SSB/CW/RTTY	AFS1	High	High	Low	Low	AFS2	High	High	Low	Low
PORT	MODE																				
	WFM	FM	AM	SSB/CW/RTTY																	
AFS1	High	High	Low	Low																	
AFS2	High	High	Low	Low																	
13	UNFM	Outputs non-FM mode select signal. High : When SSB/CW/RTTY/AM modes are selected.																			
14	MINH	Outputs an audio mute signal for the analog switch (IC971). High : While transmitting in CW/RTTY modes.																			

**3-4-4 MAIN CPU PORT ALLOCATIONS  
(MAIN unit; IC2001)**

Pin number	Port name	Description
13	DASK	Input port for the external paddle (DASH). Low : During key down
14	DOTK	Input port for the external paddle (DOT) or straight key. Low : During key down
15	UNLK	Input port for the PLL unlock signal from the DDS IC (PLL unit; IC101) and PLL IC (PLL unit; IC461). Low : while PLL unlock
16	TKEY	Input port for transmit control signal from the optional AT-180/AH-4 antenna tuners.
17	TCON	Input port for the optional antenna tuner connection detection. High : When the optional antenna tuner is connected.
18	SQSS	Outputs a squelch control signal for the external unit.
19	PWK	Input port for the [POWER] switch. Low : When the [POWER] switch is pushed.
20	POWS	Outputs the switching relay (PA unit; RL591) control signal. High : While power is ON.
21	ATST	Outputs start signal for the optional AT-180 antenna tuner.
22	BEEP	Output port : Beep audio signals while receiving. : CW side tone signals while transmitting.
23	AHST	Outputs start signal for the optional AH-4
24	AFMS	Outputs squelch mute control signal, applied to the AF mute switch (MAIN board; Q772). Low : While squelch is closed.
30	CTCV	Input port for the CTCSS decode signal from the low-pass filter (IC811C).
31	SNDL	Input port from the [RTTY] or [MIC] connector. High : While transmitting.
32	VOXL	Input port for the VOX voltage.
33	AVXL	Input port for the anti-VOX voltage.
34	ALCV	ALC level input port for the ALC meter indication.
37	TONE	Outputs subaudible tone signals.
39	SPBK	Input port for the optional UT-102 (Voice synthesizer unit) activation signal. High : During speech synthesis.

**(MAIN unit; IC2001)–Continued**

Pin number	Port name	Description
40	ETON	Outputs 1750 Hz European tone signal.
41	MSST	Outputs a strobe signal for the optional UT-102 (Voice synthesizer unit).
42	MDT	Outputs serial data for the I/O expanders, optional AT-180/UT-102.
43	MCK	Outputs a clock signal for the I/O expanders, optional AT-180/ UT-102.
44	BSTB	Outputs a strobe signal for the I/O expander ICs (IC2231, IC2232).
45	DSST	Outputs a strobe signal for the I/O expander ICs (IC2221, IC2222).
46	ASTB	Outputs a strobe signal for the D/A converter IC (IC2201).
48	PBST	Outputs a strobe signal for the BFO DDS IC (PLL unit; IC901).
49–51	CON2–CON0	Output mode control signals for the 1st LO DDS IC (PLL unit; IC101).
52	PDST	Outputs a strobe signal for the 1st LO DDS IC (PLL unit; IC101).
53	PMST	Outputs a strobe signal for the 1st LO PLL IC (PLL unit; IC461).
54	PDT	Outputs serial data for the DDS ICs (PLL unit; IC101, IC901) and PLL IC (PLL unit; IC461).
55	PCK	Outputs a clock signal for the DDS ICs (PLL unit; IC101, IC901) and PLL IC (PLL unit; IC461).
61	AFGS	Outputs AGC rate select signal Low : When AGC fast is selected.
62	NBS	Outputs the NB switch (Q635) control signal. High : When the [NB] is turned ON, except FM/WFM modes.
63	ATTS	Outputs the attenuator circuit control signal. High : When the [ATT] is turned ON.
71	FMST	Outputs a strobe signal for the TX FM PLL IC (IC1011).
74	SNDS	Input port for transmit/receive switching signals for the [ACC] connector. Low : While transmitting.
75	KDS	Outputs a CW keying signal or RTTY TX signal.
78	LTXD	Output port for CI-V bus line.
79	LRXD	Input port for CI-V bus line.

# SECTION 4 ADJUSTMENT PROCEDURE

## 4-1 PREPARATION BEFORE SARVICING

### • REQUIRED TEST EQUIPMENT

EQUIPMENT	GREDE AND RANGE	EQUIPMENT	GREDE AND RENGE
DC power supply	Output voltage : 13.8 V DC Current capacity : 30 A or more	Distortion meter	Frequency range : 1 kHz $\pm$ 10 % Measuring range : 1–100 %
RF power meter (terminated type)	Measuring range : 10–200 W Frequency range : 1.8–500 MHz Impedance : 50 $\Omega$ SWR : Less than 1.2 : 1	Oscilloscope	Frequency range : DC–100 MHz Measuring range : 0.01–10 V
Frequency counter	Frequency range : 0.1–500 MHz Frequency accuracy : $\pm$ 1 ppm or better Sensitivity : 100 mV or better	Digital multimeter	Input impeadance : 10 M $\Omega$ /DC or beter
RF voltmeter	Frequency range : 0.1–500 MHz Measuring range : 0.01–10 V	AC millivoltmeter	Measuring range : 10 mV–10 V
Standard signal generator (SSG)	Frequency range : 0.1–30 MHz Output level : 0.1 $\mu$ V–32 mV (–127 to –17 dBm)	DC voltmeter	Input impedance : 50 k $\Omega$ /V DC or better
FM deviation meter	Frequency range : 0–500 MHz Measuring range : 0 to $\pm$ 5 kHz	DC ammeter	Measurement capability: 1 A/50 A
Modulation analyzer	Frequency range : At least 500 MHz Measuring range : 0–100 %	Audio generator	Frequency range : 300–3000 Hz Measuring range : 1–500 mV
		Spectram analyzer	Frequency range : At least 1000 MHz Spectrum bandwidth : 100 kHz or more
		Attenuator	Power attenuation : 50 or 60 dB Capacity : 150 W or more
		External speaker	Input impedance : 8 $\Omega$ Capacity : 5 W or more

### • CONNECTIONS

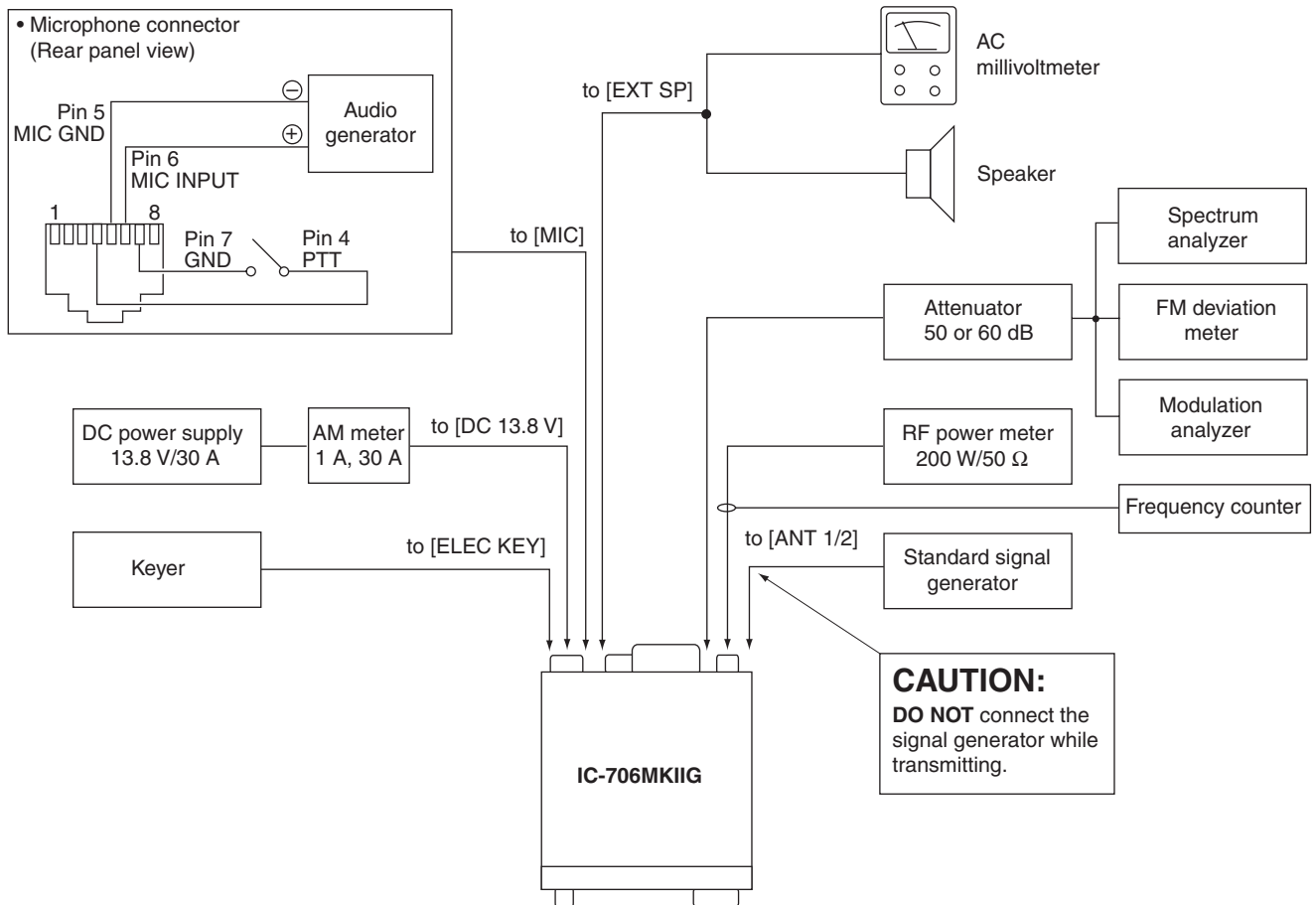

## 4-2 PLL ADJUSTMENTS

ADJUSTMENT	ADJUSTMENT CONDITION	MEASUREMENT		VALUE	ADJUSTMENT POINT		
		UNIT	LOCATION		UNIT	ADJUST	
REFERENCE FREQUENCY	1	<ul style="list-style-type: none"> <li>• Display frequency: Any</li> <li>• L623 (PLL unit) : Center</li> <li>• Receiving</li> </ul>	PLL	Connect an RF voltmeter to check point P681.	Maximum level (0 dB or more)	PLL	L681, L682
	2			Connect a frequency counter to check point P681.			60.000000 MHz
REFERENCE LOOP LOCK VOLTAGE	1	<ul style="list-style-type: none"> <li>• Display frequency: 0.0300 MHz</li> <li>• Mode : USB</li> <li>• Receiving</li> </ul>	PLL	Connect a digital multimeter or oscilloscope to check point CP131.	2.0 V	PLL	C4
MAIN LOOP LOCK VOLTAGE	1	<ul style="list-style-type: none"> <li>• Display frequency: 128.99999 MHz</li> <li>• Mode : USB</li> <li>• Receiving</li> </ul>	PLL	Connect a digital multimeter or oscilloscope to check point CP401.	4.0 V	PLL	C306
	2	<ul style="list-style-type: none"> <li>• Display frequency: 199.99999 MHz</li> <li>• Mode : USB</li> <li>• Receiving</li> </ul>			4.0 V		C335
	3	<ul style="list-style-type: none"> <li>• Display frequency: 470.00000 MHz</li> <li>• Mode : USB</li> <li>• Receiving</li> </ul>			4.0 V		C367

## 4-3 TRANSMITTER ADJUSTMENTS

ADJUSTMENT	ADJUSTMENT CONDITION	MEASUREMENT		VALUE	ADJUSTMENT POINT			
		UNIT	LOCATION		UNIT	ADJUST		
TRANSMIT TOTAL GAIN	1	<ul style="list-style-type: none"> <li>• Display frequency: 14.10000 MHz</li> <li>• Mode : USB</li> <li>• [Q1 RF POWER] : H</li> <li>• Connect an audio generator to [MIC] connector and set as: 1.5 kHz/3 mV</li> <li>• Transmitting</li> </ul>	Rear Panel	Connect an RF power meter to [ANT1] connector.	Maximum RF power	MAIN	L511, L512, L562, L563, L566	
	2						• Transmitting	50 W
OUTPUT POWER	1	<ul style="list-style-type: none"> <li>• Display frequency: 14.10000 MHz</li> <li>• Mode : USB</li> <li>• [Q2 MIC GAIN] : 5</li> <li>• Connect an audio generator to [MIC] connector and set as: 1.5 kHz/30 mV</li> <li>• Transmitting</li> </ul>	Rear Panel	Connect an RF power meter to [ANT1] connector.	100 W	MAIN	R1082	
	2	<ul style="list-style-type: none"> <li>• Display frequency: 52.00000 MHz</li> <li>• Transmitting</li> </ul>			100 W		R1084	
	3	<ul style="list-style-type: none"> <li>• Display frequency: 145.00000 MHz</li> <li>• Transmitting</li> </ul>			Connect an RF power meter to [ANT2] connector.		50 W	R1086
	4	<ul style="list-style-type: none"> <li>• Display frequency: 435.00000 MHz</li> <li>• Transmitting</li> </ul>			20 W		R1088	
CARRIER SUPPRESSION	1	<ul style="list-style-type: none"> <li>• Display frequency: 14.10000 MHz</li> <li>• Mode : USB and LSB</li> <li>• Apply no signal to [MIC] connector.</li> <li>• Transmitting</li> </ul>	Rear Panel	Connect a spectrum analyzer to [ANT1] connector via an attenuator.	Minimum carrier level	MAIN	R1045	

• PLL AND PA UNITS

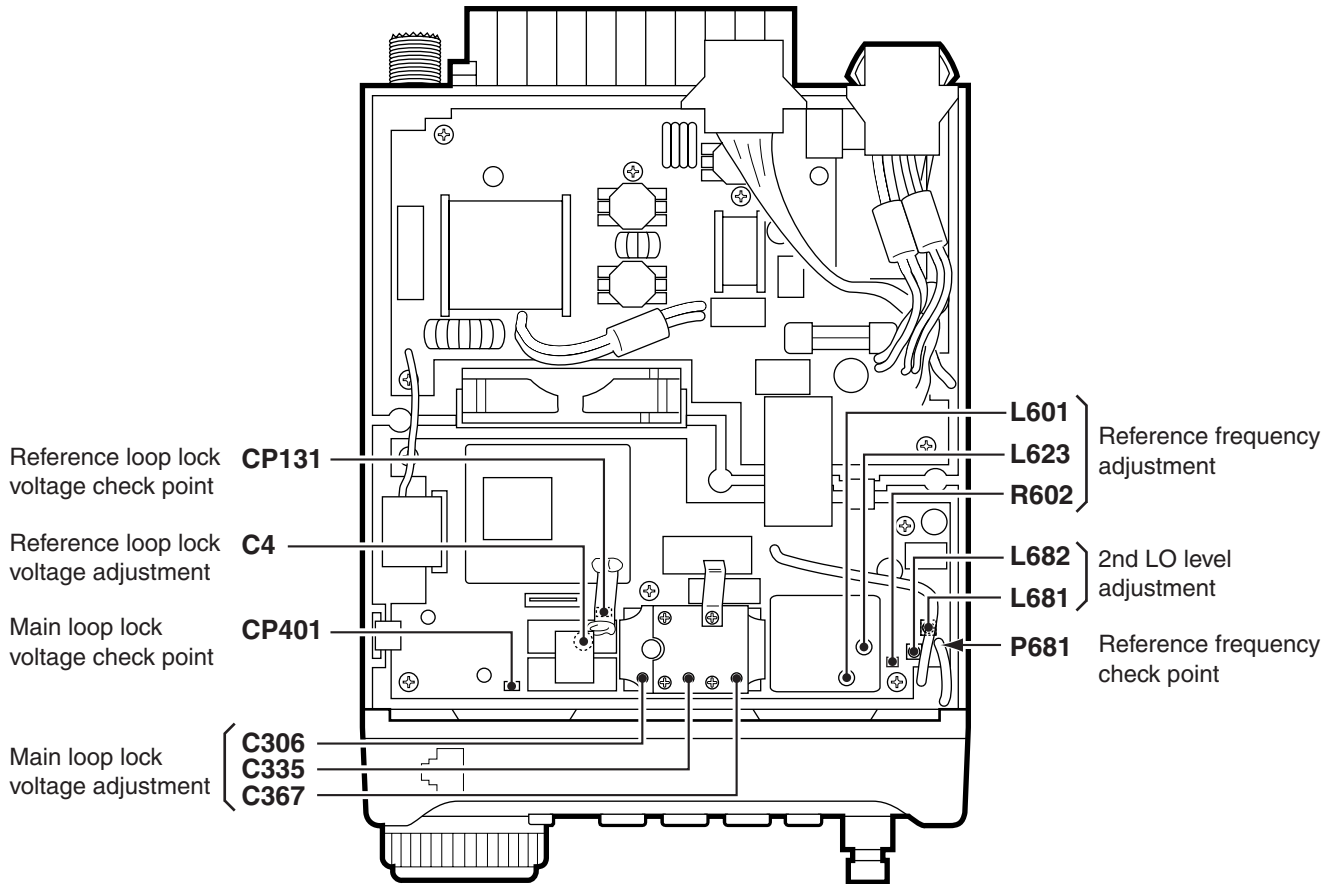

• MAIN UNIT

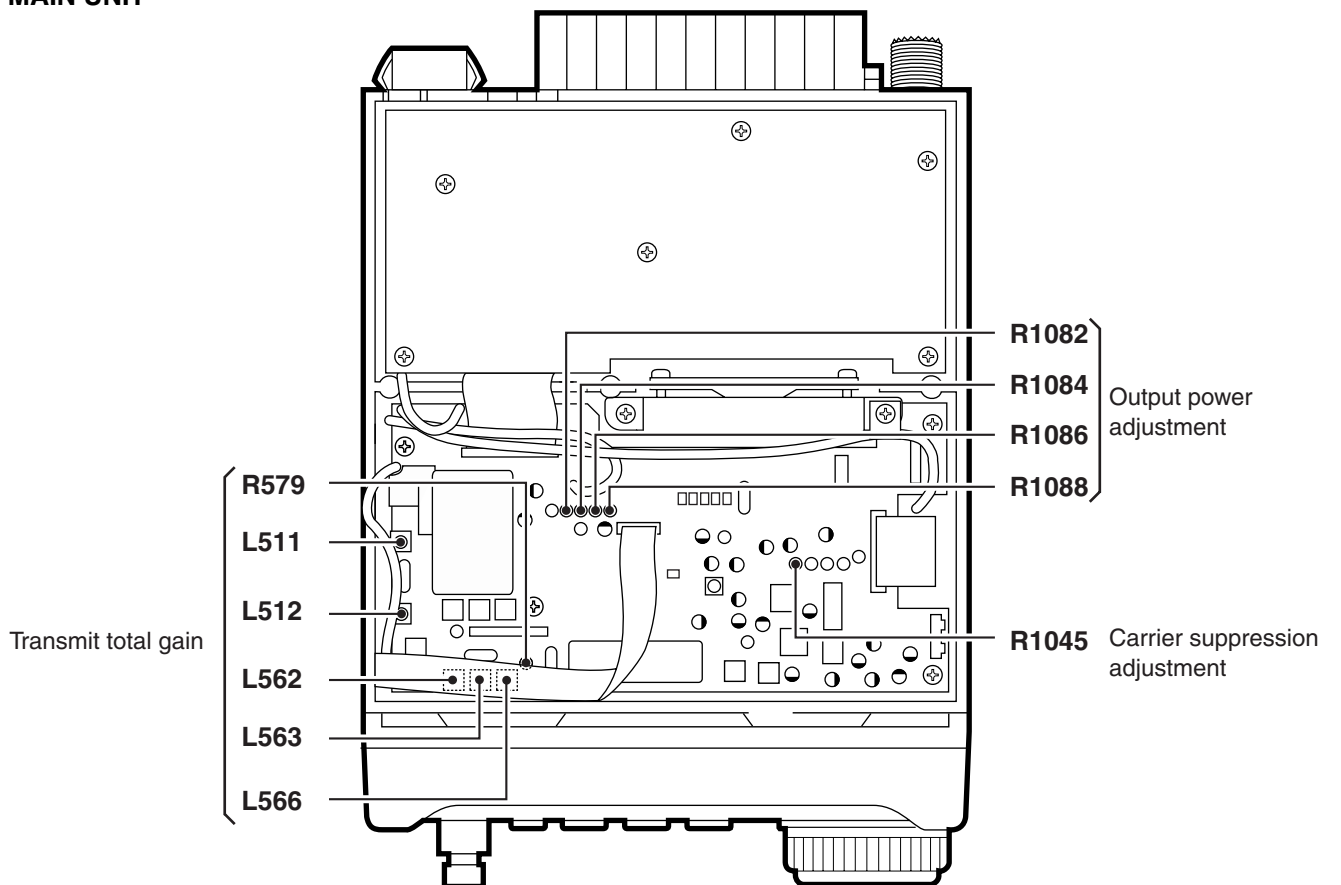

## TRANSMITTER ADJUSTMENTS (continued)

ADJUSTMENT	ADJUSTMENT CONDITION	MEASUREMENT		VALUE	ADJUSTMENT POINT	
		UNIT	LOCATION		UNIT	ADJUST
FM VCO	1 <ul style="list-style-type: none"> <li>• Display frequency: 29.10000 MHz</li> <li>• Mode : FM</li> <li>• [Q1 RF POWER] : H</li> <li>• [M4 TON] : OFF</li> <li>• Apply no signal to [MIC] connector.</li> <li>• Transmitting</li> </ul>	MAIN	Connect a digital multimeter to check point CP1011.	1.8 V	MAIN	C1022
FM DEVIATION	1 <ul style="list-style-type: none"> <li>• Display frequency: 29.10000 MHz</li> <li>• Mode : FM</li> <li>• [Q1 RF POWER] : H</li> <li>• [M4 TON] : OFF</li> <li>• [Q2 MIC GAIN] : 5</li> <li>• Connect an audio generator to [MIC] connector and set as: 1 kHz/30 mV</li> <li>• Transmitting</li> </ul>	Rear Panel	Connect an FM deviation meter to [ANT1] connector via an attenuator.	±4.5 kHz	MAIN	R1002
RESIDUAL AM	1 <ul style="list-style-type: none"> <li>• Display frequency: 29.10000 MHz</li> <li>• Mode : FM</li> <li>• [Q1 RF POWER] : H</li> <li>• [M4 TON] : OFF</li> <li>• [Q2 MIC GAIN] : 5</li> <li>• Connect an audio generator to [MIC] connector and set as: 1 kHz/30 mV and OFF</li> <li>• Transmitting</li> </ul>		Connect an RF power meter to [ANT1] connector.	Minimum power difference with modulation and unmodulation.	MAIN	adjust in sequence L511, L512, then adjust L562, L563, L566.
	2	After adjustment, verify the TRANSMIT TOTAL GAIN and OUTPUT POWER adjustments.				
AM MODULATION	1 <ul style="list-style-type: none"> <li>• Display frequency: 14.10000 MHz</li> <li>• Mode : AM</li> <li>• [Q1 RF POWER] : H</li> <li>• [Q2 MIC GAIN] : 5</li> <li>• Disconnect the plug from J281 on the MAIN board.</li> <li>• Apply no signal to [MIC] connector.</li> <li>• Transmitting</li> </ul>	MAIN	Connect an oscilloscope to check point CP1041.	100 mVp-p	MAIN	R1042
	2 <ul style="list-style-type: none"> <li>• Connect the plug to J281 on the MAIN board.</li> <li>• Apply no signal to [MIC] connector.</li> <li>• Transmitting</li> </ul>	Rear Panel	Connect an RF power meter to [ANT1] connector.	35 W		R1080
	3 <ul style="list-style-type: none"> <li>• Connect an audio generator to [MIC] connector and set as: 1 kHz/30 mV</li> <li>• Transmitting</li> </ul>		Connect a modulation analyzer to [ANT1] connector via an attenuator.	90 % modulation		R999
CW CARRIER LEVEL	1 <ul style="list-style-type: none"> <li>• Display frequency: 14.10000 MHz</li> <li>• Mode : CW</li> <li>• [Q1 RF POWER] : H</li> <li>• [Q5 KEY SPEED] : 60</li> <li>• [M4 BRK] : BK (semi break-in)</li> <li>• CW paddle : n</li> <li>• Connect an RF power meter to [ANT1] connector.</li> <li>• Transmit dots for a while using a paddle.</li> </ul>		Connect an oscilloscope to check point CP921 and [ANT1] connector.	At the point where the CW carrier completely comes up in a 10 msec. delay after CP921 voltage comes up.	MAIN	R921

• MAIN UNIT

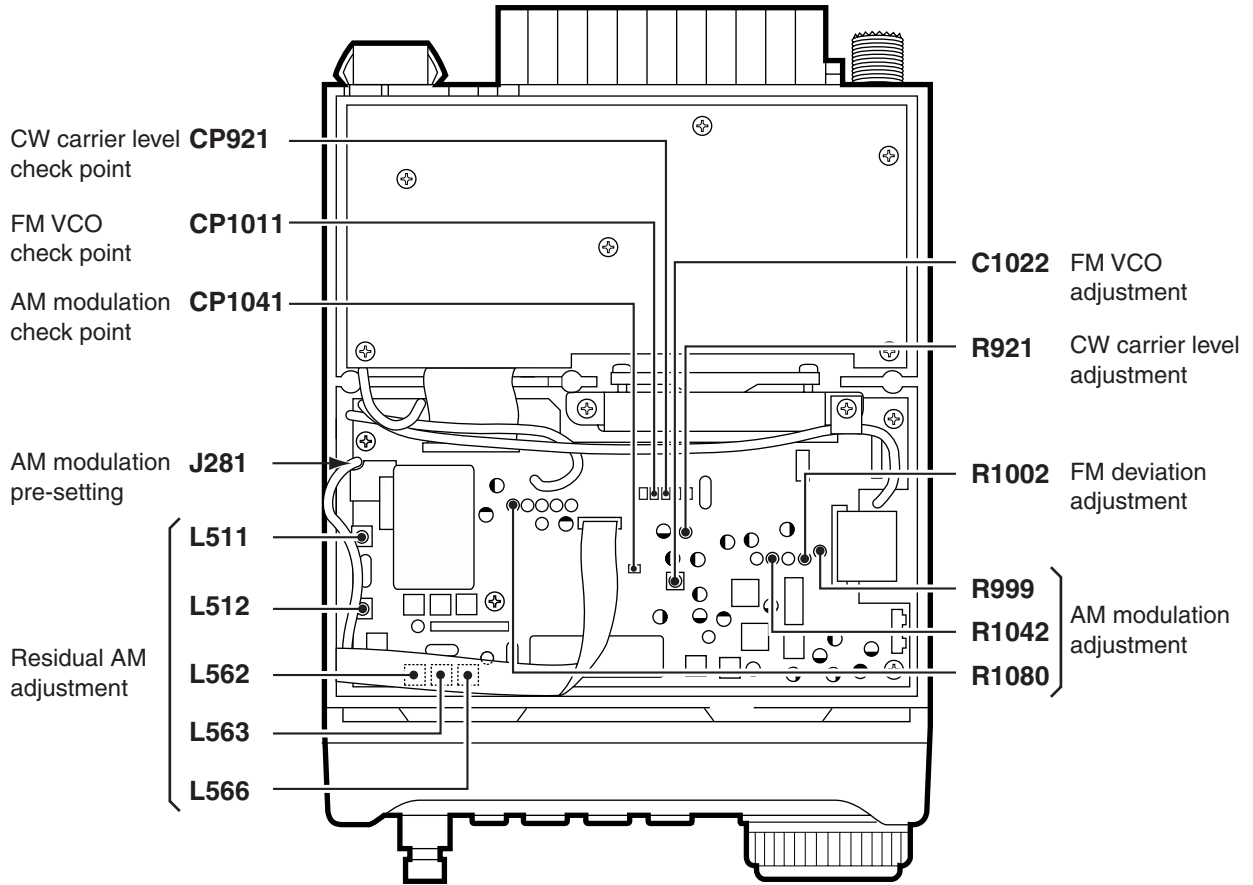

## TRANSMITTER ADJUSTMENTS (continued)

ADJUSTMENT	ADJUSTMENT CONDITION	MEASUREMENT		VALUE	ADJUSTMENT POINT			
		UNIT	LOCATION		UNIT	ADJUST		
IDLING CURRENT (for drive amplifiers)	1	<ul style="list-style-type: none"> <li>• Display frequency: 14.10000 MHz</li> <li>• Mode : USB</li> <li>• [Q2 MIC GAIN] : 1 (minimum)</li> <li>• turn R162, R174, R175, R214, R231 (on the PA unit) to maximum counterclockwise position.</li> <li>• Disconnect the plug from J571 on the PA unit.</li> <li>• Transmitting</li> </ul>	PA	Connect a DC ammeter between the DC power supply and transceiver's DC power socket (P601 on the PA unit).	1.0 A increase from that R162 is in maximum counterclockwise position.	PA	R162	
	2	<ul style="list-style-type: none"> <li>• Display frequency: 145.10000 MHz</li> <li>• Mode : USB</li> <li>• [Q2 MIC GAIN] : 1 (minimum)</li> <li>• Transmitting</li> </ul>			2.0 A increase from step 1.		R214	
	(for final amplifiers)	3	<ul style="list-style-type: none"> <li>• Display frequency: 14.10000 MHz</li> <li>• Mode : USB</li> <li>• [Q2 MIC GAIN] : 1 (minimum)</li> <li>• Transmitting</li> </ul>				1.0 A increase from that R174 is in maximum counterclockwise position.	R174
		4	<ul style="list-style-type: none"> <li>• Transmitting</li> </ul>				1.0 A increase from step 3.	R175
		5	<ul style="list-style-type: none"> <li>• Display frequency: 145.10000 MHz</li> <li>• Mode : USB</li> <li>• [Q2 MIC GAIN] : 1 (minimum)</li> <li>• Transmitting</li> </ul>				100 mA increase from step 4.	R231
SWR DETECTION	1	<ul style="list-style-type: none"> <li>• Display frequency: 14.10000 MHz</li> <li>• Mode : USB</li> <li>• Ground CP1071 on the MAIN board.</li> <li>• Connect an audio generator to [MIC] connector and set as: 1.5 kHz/30 mV</li> <li>• Transmitting</li> </ul>	Rear Panel	Connect an RF power meter to [ANT1] connector.	100 W	Quick set mode	Q2 MIC GAIN	
	2	<ul style="list-style-type: none"> <li>• Transmitting</li> </ul>	FILTER	Connect a digital multimeter to check point W16.	Minimum voltage	FILTER	C58	
	3	After remove the jumper wire from CP1071 on the MAIN board.						



• PA UNIT

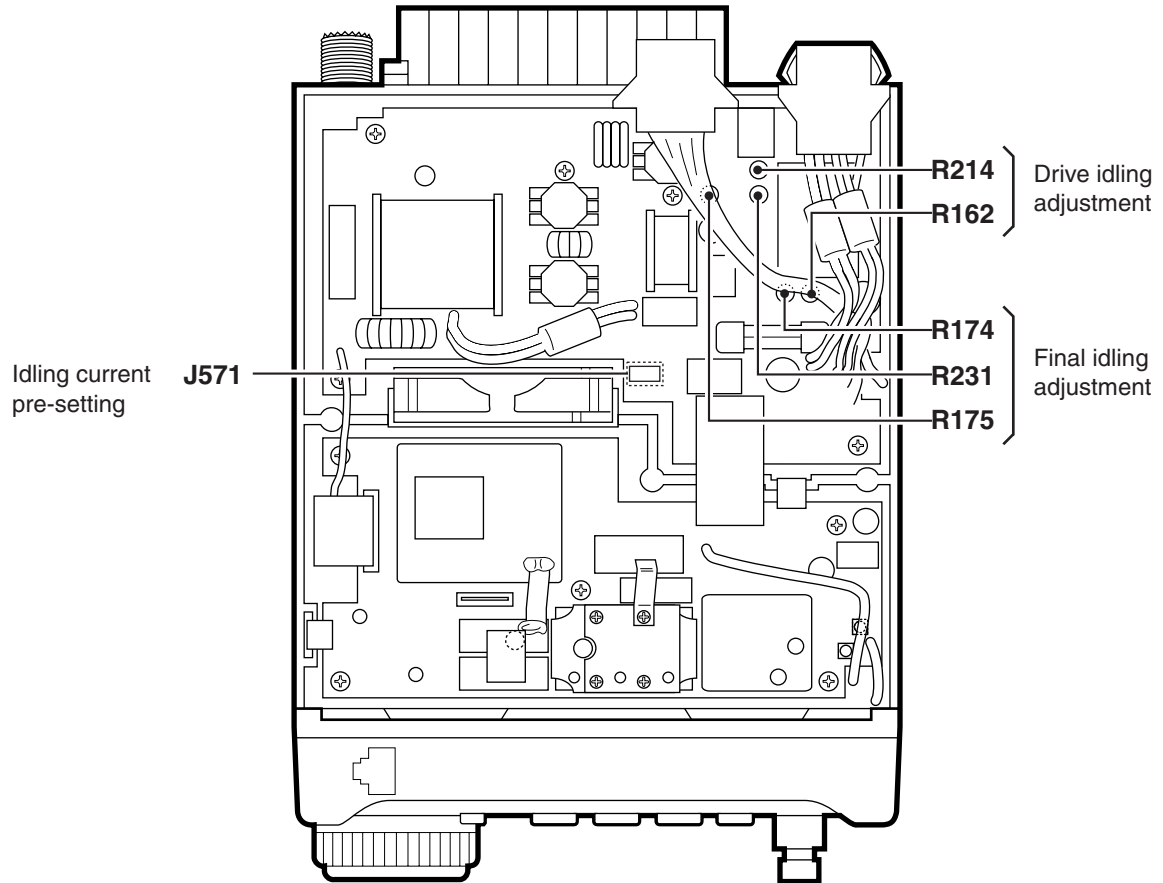

• MAIN AND FILTER UNITS

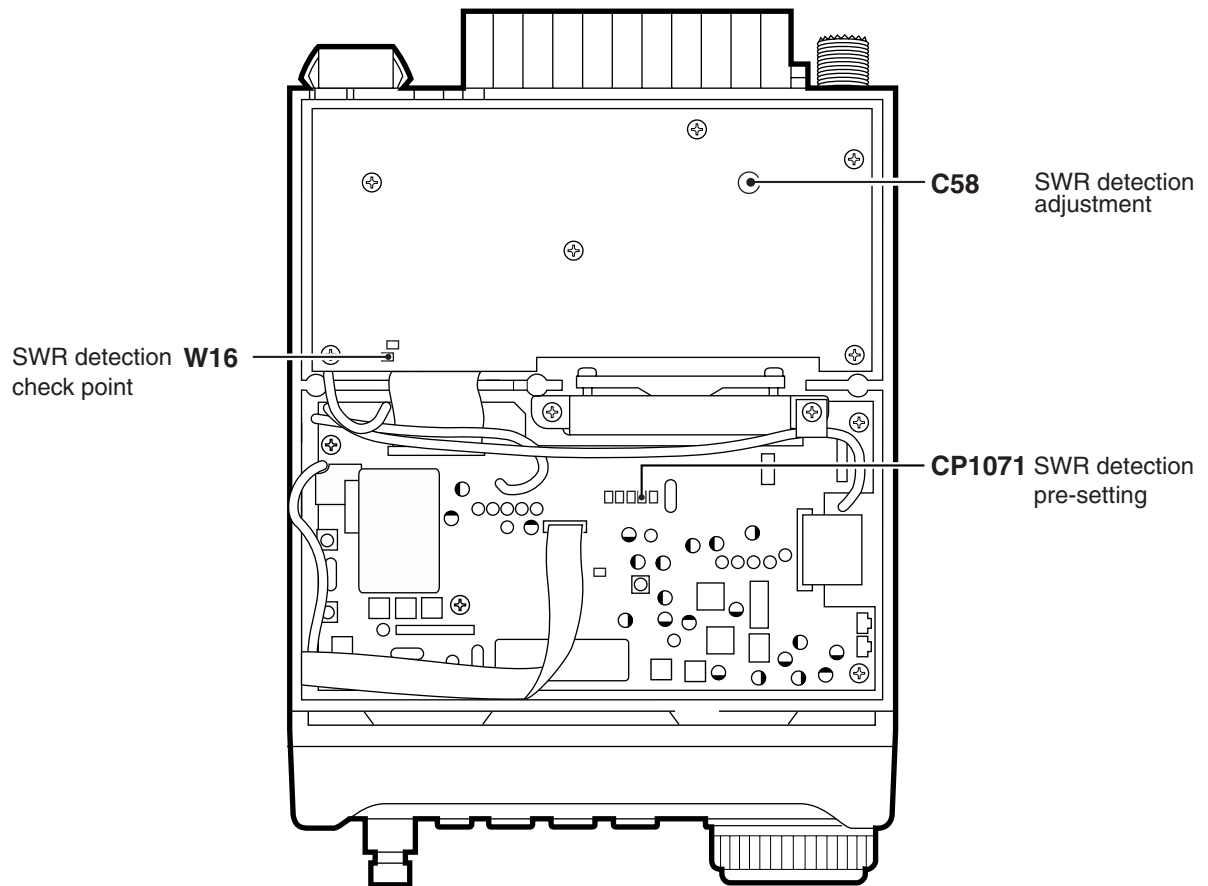

## 4-4 RECEIVER ADJUSTMENTS

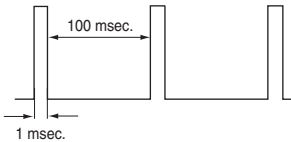





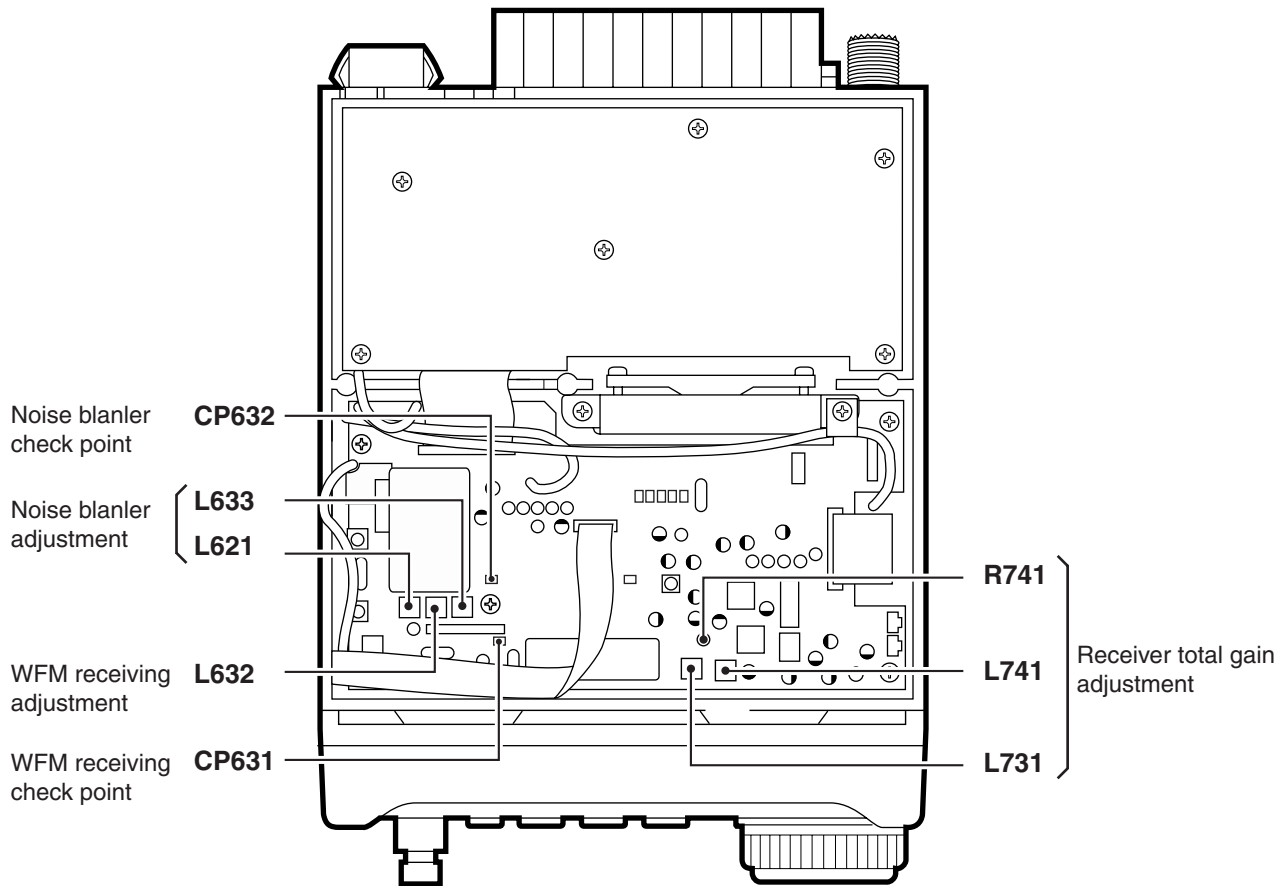



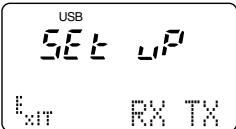

ADJUSTMENT	ADJUSTMENT CONDITION	MEASUREMENT		VALUE	ADJUSTMENT POINT	
		UNIT	LOCATION		UNIT	ADJUST
RECEIVER TOTAL GAIN	1 <ul style="list-style-type: none"> <li>• Display freq. : 14.10000 MHz</li> <li>• Mode : USB</li> <li>• [RIT] : OFF</li> <li>• [M4 AGC] : Fast (F AGC)</li> <li>• [M3 NB] : OFF</li> <li>• [P.AMP/ATT] : Preamp ON</li> <li>• Connect a standard signal generator to the [ANT1] connector and set as: <ul style="list-style-type: none"> <li>Frequency : 14.10150 MHz</li> <li>Level : 0.5 <math>\mu</math>V* (-113 dBm)</li> <li>Modulation : OFF</li> </ul> </li> <li>• Receiving</li> </ul>	Rear Panel	Connect an AC millivoltmeter to the [EXT SP] jack with an 8 $\Omega$ dummy load.	Muximum AF output level	MAIN	L731, L741
	2 <ul style="list-style-type: none"> <li>• [P.AMP/ATT] : Preamp OFF</li> <li>• Set an SSG as: <ul style="list-style-type: none"> <li>Frequency : 14.10150 MHz</li> <li>Level : 500 <math>\mu</math>V* (-53 dBm) and OFF</li> <li>Modulation : OFF</li> </ul> </li> <li>• Receiving</li> </ul>	Rear Panel	Connect an AC millivoltmeter to the [EXT SP] jack with a 8 $\Omega$ dummy load.	30 dB of AF level difference	MAIN	R741
WFM RECEIVING	1 <ul style="list-style-type: none"> <li>• Display freq. : 14.10000 MHz</li> <li>• Mode : WFM</li> <li>• Set an SSG as: <ul style="list-style-type: none"> <li>Frequency : 14.10000 MHz</li> <li>Level : 500 <math>\mu</math>V* (-53 dBm)</li> <li>Modulation : OFF</li> </ul> </li> <li>• Receiving</li> </ul>	MAIN	Connect a digital multimeter or oscilloscope to check point CP631.	4.0 V	MAIN	L632
NOISE BLANKER	1 <ul style="list-style-type: none"> <li>• Display freq. : 14.10000 MHz</li> <li>• Mode : USB</li> <li>• [P.AMP/ATT] : Preamp ON</li> <li>• [M3 NB] : OFF</li> <li>• R623 (MAIN) : Center</li> <li>• Connect an SSG to the [ANT1] connector and set as: <ul style="list-style-type: none"> <li>Frequency : 14.1015 MHz</li> <li>Level : 18 <math>\mu</math>V* (-82 dBm)</li> <li>Modulation : OFF</li> </ul> </li> <li>and apply the following signal to the [ANT1] connector.</li> </ul>  <ul style="list-style-type: none"> <li>• Receiving</li> </ul>	MAIN	Connect an oscilloscope to check point CP632.	Adjust the maximum noise wave displayed on the oscilloscope.	MAIN	L621, L633
	2 <ul style="list-style-type: none"> <li>• [M3 NB] : ON</li> <li>• Set an SSG as: <ul style="list-style-type: none"> <li>Level : 10 <math>\mu</math>V* (-87 dBm)</li> <li>Modulation : OFF</li> </ul> </li> <li>• Receiving</li> </ul>					

\*This output level of the standard signal generator (SSG) is indicated as SSG's open circuit.

• MAIN UNIT



## 4-5 SET MODE ADJUSTMENT

ADJUSTMENT	ADJUSTMENT CONDITION	DISPLAY	OPERATION
ENTERING ADJUSTMENT SET MODE	1 <ul style="list-style-type: none"> <li>Enter adjustment set mode: <ol style="list-style-type: none"> <li>Turn power OFF.</li> <li>Terminate the [REMOTE] jack with a 3.5(d) mm mini-plug.</li> <li>While pushing [P.AMP/ATT] and [TUNE/CALL], turn power ON.</li> </ol> </li> </ul>		Push [F-3 (TX)] to enter the TX adjustment setting mode. Then advance to the following setting, or push [UP]/[DN] to scroll the display.
Id APC	1 <ul style="list-style-type: none"> <li>Connect an RF power meter to [ANT1] connector.</li> <li>Connect a DC ammeter between the DC power supply and transceiver's DC power socket (P601 on the PA unit).</li> <li>Transmit using an external PTT switch.</li> </ul>		Set a total current at 15 A by adjusting R1125 on the MAIN board. Push [MENU] to set the "SET IdAPC" after returning receiving condition.
FILTER CALIBRATION	1 <ul style="list-style-type: none"> <li>Connect an RF power meter to [ANT1] connector.</li> </ul>	GO FILTER CAL	Push and hold [MENU (GO)] to make the calibration. • Transceiver transmits for a while.
POWER METER (14 MHz)	1 <ul style="list-style-type: none"> <li>Connect an RF power meter to [ANT1] connector.</li> <li>Transmit using an external PTT switch.</li> </ul>		Set to 90 W using [MAIN DIAL], then push [MENU] while transmitting.
	2 <ul style="list-style-type: none"> <li>Transmit using an external PTT switch.</li> </ul>		Set to 50 W using [MAIN DIAL], then push [MENU] while transmitting.
TUNING POWER (14 MHz)	1 <ul style="list-style-type: none"> <li>Connect an RF power meter to [ANT1] connector.</li> <li>Transmit using an external PTT switch.</li> </ul>		Set to 10 W using [MAIN DIAL], then push [MENU] while transmitting.
	(50 MHz) 2 <ul style="list-style-type: none"> <li>Transmit using an external PTT switch.</li> </ul>		Set to 10 W using [MAIN DIAL], then push [MENU] while transmitting.
POWER METER (145 MHz)	1 <ul style="list-style-type: none"> <li>Connect an RF power meter to [ANT2] connector.</li> <li>Transmit using an external PTT switch.</li> </ul>		Set to 45 W using [MAIN DIAL], then push [MENU] while transmitting.
	2 <ul style="list-style-type: none"> <li>Transmit using an external PTT switch.</li> </ul>		Set to 25 W using [MAIN DIAL], then push [MENU] while transmitting.
POWER METER (430 MHz)	1 <ul style="list-style-type: none"> <li>Connect an RF power meter to [ANT2] connector.</li> <li>Transmit using an external PTT switch.</li> </ul>		Set to 18 W using [MAIN DIAL], then push [MENU] while transmitting.
	2 <ul style="list-style-type: none"> <li>Transmit using an external PTT switch.</li> </ul>		Set to 10 W using [MAIN DIAL], then push [MENU] while transmitting.
ALC METER	1 <ul style="list-style-type: none"> <li>Connect an RF power meter to [ANT1] connector.</li> <li>Connect an audio generator to [MIC] connector and set as : Level : 1.5 kHz/30mV</li> <li>Transmit using an external PTT switch.</li> </ul>		Push and hold [MENU] to set ALC reference level while transmitting.
SWR METER	1 <ul style="list-style-type: none"> <li>Connect a 50 Ω dummy load or power meter to [ANT1] connector.</li> </ul>		Push [MENU] to set SWR reference level.
	2 <ul style="list-style-type: none"> <li>Connect a 50 Ω dummy load or power meter to [ANT1] connector.</li> </ul>		Push [MENU] to set SWR2 level. • The display returns to the same as the ADJUSTMENT SET MODE above.
Push [F-1 (EXIT)] to exit adjustment set mode.			

## SET MODE ADJUSTMENT (continued)

ADJUSTMENT	ADJUSTMENT CONDITION	DISPLAY	OPERATION
ENTERING ADJUSTMENT SET MODE	1 <ul style="list-style-type: none"> <li>Enter adjustment set mode: <ol style="list-style-type: none"> <li>Turn power OFF.</li> <li>Terminate the [REMOTE] jack with a 3.5(d) mm mini-plug.</li> <li>While pushing [P.AMP/ATT] and [TUNE/CALL], turn power ON.</li> </ol> </li> </ul>		Push [F-2 (RX)] to enter the RX adjustment setting mode. Then advance to the following setting, or push [UP]/[DN] to scroll the display.
SENSITIVITY	1 <ul style="list-style-type: none"> <li>Connect a standard signal generator to [ANT2] and set as: <ul style="list-style-type: none"> <li>Frequency : 60.05150 MHz</li> <li>Modulation : OFF</li> </ul> </li> <li>Receiving</li> </ul>		Set a connected SSG's level at 10 dB of S/N ratio with AC millivoltmeter.
	2 <ul style="list-style-type: none"> <li>Receiving</li> </ul>		Set maximum AF level using the [MAIN DIAL], then push [MENU] to set the "VHF1 BPF1 L".
	3 <ul style="list-style-type: none"> <li>Same operation as step 2 for the listed BPFs.</li> <li>Set an SSG as: <ul style="list-style-type: none"> <li>Modulation : OFF</li> <li>VHF1 BPF2 L : 60.05150 MHz</li> <li>VHF1 BPF1 M : 90.50150 MHz</li> <li>VHF1 BPF1 H : 128.9515 MHz</li> <li>VHF2 BPF1 L : 129.1015 MHz</li> <li>VHF2 BPF1 M : 145.1515 MHz</li> <li>VHF2 BPF1 H : 170.0015 MHz</li> <li>UHF BPF1 L : 400.0015 MHz</li> <li>UHF BPF1 M : 435.1515 MHz</li> <li>UHF BPF1 H : 470.0015 MHz</li> </ul> </li> <li>Receiving</li> </ul>	<ul style="list-style-type: none"> <li>VHF1 BPF2 M : Same as left</li> <li>VHF1 BPF2 H : Same as left</li> <li>VHF2 BPF2 L : Same as left</li> <li>VHF2 BPF2 M : Same as left</li> <li>VHF2 BPF2 H : Same as left</li> <li>UHF BPF2 L : Same as left</li> <li>UHF BPF2 M : Same as left</li> <li>UHF BPF2 H : Same as left</li> </ul>	
S-METER	1 <ul style="list-style-type: none"> <li>Connect an SSG to [ANT1] connector and set as: <ul style="list-style-type: none"> <li>Frequency : 14.1515 MHz</li> <li>Level : OFF</li> </ul> </li> <li>Receiving</li> </ul>		Push [MENU] to set the "S0 level".
	2 <ul style="list-style-type: none"> <li>Set an SSG as : <ul style="list-style-type: none"> <li>Level : 50 μV (-73 dBm)</li> <li>Modulation : OFF</li> </ul> </li> <li>Receiving</li> </ul>		Push [MENU] to set the "S9 level".
	3 <ul style="list-style-type: none"> <li>Set an SSG as : <ul style="list-style-type: none"> <li>Level : 50 mV (-13 dBm)</li> <li>Modulation : OFF</li> </ul> </li> <li>Receiving</li> </ul>		Push [MENU] to set the "+60 dB level". • The display returns to the same as the ADJUSTMENT SET MODE above.
	Push [F-1 (EXIT)] to exit adjustment set mode.		

# SECTION 5

# PARTS LIST

## [FRONT UNIT]

REF NO.	ORDER NO.	DESCRIPTION
W1	8900006040	CBL OPC-593 (N:13 L:50)
W2	8900006252	CBL OPC-610B
EP1	6910013810	E.OTH RMS20-100-201-1C

## [DISPLAY UNIT]

REF NO.	ORDER NO.	DESCRIPTION
IC1	1140009731	S.IC HD6433832SD78HV (SX-2177S)
IC2	1130007960	S.IC SED1522FOC (QFP15-100PIN)
IC3	1130011130	S.IC BU4030BF-E2
IC4	1110005781	S.IC S-80945CLMC-G7FG
IC5	1110005761	S.IC S-812C50AUA-C3E-G
Q1	1590002310	S.TR DTC114EE TL
Q2	1520000460	S.TR 2SB1132 T100 R
Q3	1530002060	S.TR 2SC4081 T106 R
Q4	1540000441	S.TR 2SD1619T-TD-E
Q8	1590002370	S.TR XP4111 (TX)
Q9	1590001870	S.TR DTA114EE TL
Q10	1530002060	S.TR 2SC4081 T106 R
Q11	1520000380	TR 2SB1143 S
Q12	1590002370	S.TR XP4111 (TX)
Q13	1520000460	S.TR 2SB1132 T100 R
Q14	1530002060	S.TR 2SC4081 T106 R
Q15	1590001870	S.TR DTA114EE TL
Q16	1590002771	S.FET CPH3404-TL-E
D1	1750000370	S.DIO DA221 TL
D2	1750000370	S.DIO DA221 TL
D3	1750000370	S.DIO DA221 TL
D5	1790001250	S.DIO MA2S111-(TX)
D6	1790001250	S.DIO MA2S111-(TX)
D7	1160000140	S.DIO DAP222 TL
D9	1790001250	S.DIO MA2S111-(TX)
D10	1790001250	S.DIO MA2S111-(TX)
D11	1160000060	S.DIO DAN202U T106
D12	1790001250	S.DIO MA2S111-(TX)
D13	1160000060	S.DIO DAN202U T106
D14	1160000140	S.DIO DAP222 TL
D15	1160000140	S.DIO DAP222 TL
D16	1160000140	S.DIO DAP222 TL
X1	6050009661	S.XTL MA-406 (9.8304 MHz-F)
L1	6200003261	S.COL NLV32T-101J
L2	6200003950	S.COL HF50ACC 322513-T
L3	6200003950	S.COL HF50ACC 322513-T
L4	6200003950	S.COL HF50ACC 322513-T
L5	6200003950	S.COL HF50ACC 322513-T
R1	7030003340	S.RES ERJ3GEYJ 151 V (150)
R2	7030003400	S.RES ERJ3GEYJ 471 V (470)
R3	7030003400	S.RES ERJ3GEYJ 471 V (470)
R4	7030003440	S.RES ERJ3GEYJ 102 V (1 k)
R5	7030003340	S.RES ERJ3GEYJ 151 V (150)
R6	7030003440	S.RES ERJ3GEYJ 102 V (1 k)
R7	7030003440	S.RES ERJ3GEYJ 102 V (1 k)
R8	7030003590	S.RES ERJ3GEYJ 183 V (18 k)
R9	7030003560	S.RES ERJ3GEYJ 103 V (10 k)
R10	7030003590	S.RES ERJ3GEYJ 183 V (18 k)
R11	7030003560	S.RES ERJ3GEYJ 103 V (10 k)
R12	7030003590	S.RES ERJ3GEYJ 183 V (18 k)
R13	7030003560	S.RES ERJ3GEYJ 103 V (10 k)
R14	7030003590	S.RES ERJ3GEYJ 183 V (18 k)
R15	7030003560	S.RES ERJ3GEYJ 103 V (10 k)
R16	7030003590	S.RES ERJ3GEYJ 183 V (18 k)
R17	7030003560	S.RES ERJ3GEYJ 103 V (10 k)
R18	7030003590	S.RES ERJ3GEYJ 183 V (18 k)
R19	7030003560	S.RES ERJ3GEYJ 103 V (10 k)
R20	7030003560	S.RES ERJ3GEYJ 103 V (10 k)
R21	7030003560	S.RES ERJ3GEYJ 103 V (10 k)
R22	7030003560	S.RES ERJ3GEYJ 103 V (10 k)
R23	7030003560	S.RES ERJ3GEYJ 103 V (10 k)
R24	7030003560	S.RES ERJ3GEYJ 103 V (10 k)
R25	7030003560	S.RES ERJ3GEYJ 103 V (10 k)
R26	7030003520	S.RES ERJ3GEYJ 472 V (4.7 k)
R27	7030003520	S.RES ERJ3GEYJ 472 V (4.7 k)
R29	7030003520	S.RES ERJ3GEYJ 472 V (4.7 k)
R30	7030003440	S.RES ERJ3GEYJ 102 V (1 k)
R33	7030006190	S.RES ERJ12VJ2R2U (2.2)
R36	7030003440	S.RES ERJ3GEYJ 102 V (1 k)
R37	7030003600	S.RES ERJ3GEYJ 223 V (22 k)
R38	7030007110	S.RES MCR18EZJH 100
R39	7030007110	S.RES MCR18EZJH 100
R40	7030003640	S.RES ERJ3GEYJ 473 V (47 k)
R41	7030003640	S.RES ERJ3GEYJ 473 V (47 k)
R42	7030003440	S.RES ERJ3GEYJ 102 V (1 k)

## [DISPLAY UNIT]

REF NO.	ORDER NO.	DESCRIPTION
R44	7030003500	S.RES ERJ3GEYJ 332 V (3.3 k)
R45	7030003500	S.RES ERJ3GEYJ 332 V (3.3 k)
R46	7030003480	S.RES ERJ3GEYJ 222 V (2.2 k)
R47	7030003640	S.RES ERJ3GEYJ 473 V (47 k)
R49	7030003360	S.RES ERJ3GEYJ 221 V (220)
R50	7030003800	S.RES ERJ3GEYJ 105 V (1 M)
R51	7030003680	S.RES ERJ3GEYJ 104 V (100 k)
R52	7030003720	S.RES ERJ3GEYJ 224 V (220 k)
R53	7030003680	S.RES ERJ3GEYJ 104 V (100 k)
R54	7030003800	S.RES ERJ3GEYJ 105 V (1 M)
R55	7030003680	S.RES ERJ3GEYJ 104 V (100 k)
R56	7030003720	S.RES ERJ3GEYJ 224 V (220 k)
R57	7030003680	S.RES ERJ3GEYJ 104 V (100 k)
R58	7030003800	S.RES ERJ3GEYJ 105 V (1 M)
R65	7030003560	S.RES ERJ3GEYJ 103 V (10 k)
R66	7030003560	S.RES ERJ3GEYJ 103 V (10 k)
R67	7030003560	S.RES ERJ3GEYJ 103 V (10 k)
R68	7030003560	S.RES ERJ3GEYJ 103 V (10 k)
R69	7030003520	S.RES ERJ3GEYJ 472 V (4.7 k)
R70	7030003520	S.RES ERJ3GEYJ 472 V (4.7 k)
R71	7030003520	S.RES ERJ3GEYJ 472 V (4.7 k)
R72	7030003520	S.RES ERJ3GEYJ 472 V (4.7 k)
R73	7030003520	S.RES ERJ3GEYJ 472 V (4.7 k)
R74	7030003680	S.RES ERJ3GEYJ 104 V (100 k)
R75	7030003680	S.RES ERJ3GEYJ 104 V (100 k)
R76	7030003840	S.RES ERJ3GEYJ 225 V (2.2 M)
R83	7030003600	S.RES ERJ3GEYJ 223 V (22 k)
R84	7030003600	S.RES ERJ3GEYJ 223 V (22 k)
R85	7030003680	S.RES ERJ3GEYJ 104 V (100 k)
R92	7030003440	S.RES ERJ3GEYJ 102 V (1 k)
R93	7030003440	S.RES ERJ3GEYJ 102 V (1 k)
R95	7030003200	S.RES ERJ3GEYJ 100 V (10)
R96	7030003200	S.RES ERJ3GEYJ 100 V (10)
R97	7030003390	S.RES ERJ3GEYJ 391 V (390)
R98	7030003480	S.RES ERJ3GEYJ 222 V (2.2 k)
R99	7030003340	S.RES ERJ3GEYJ 151 V (150)
R100	7030003800	S.RES ERJ3GEYJ 105 V (1 M)
R101	7030003680	S.RES ERJ3GEYJ 104 V (100 k)
R102	7030003720	S.RES ERJ3GEYJ 224 V (220 k)
R103	7030003680	S.RES ERJ3GEYJ 104 V (100 k)
R104	7030003800	S.RES ERJ3GEYJ 105 V (1 M)
R105	7030003680	S.RES ERJ3GEYJ 104 V (100 k)
R106	7030003720	S.RES ERJ3GEYJ 224 V (220 k)
R107	7030003680	S.RES ERJ3GEYJ 104 V (100 k)
R108	7030003640	S.RES ERJ3GEYJ 473 V (47 k)
R109	7030003420	S.RES ERJ3GEYJ 681 V (680)
R110	7030003560	S.RES ERJ3GEYJ 103 V (10 k)
R111	7030003450	S.RES ERJ3GEYJ 122 V (1.2 k)
R112	7030003480	S.RES ERJ3GEYJ 222 V (2.2 k)
R113	7030003420	S.RES ERJ3GEYJ 681 V (680)
R114	7030003560	S.RES ERJ3GEYJ 103 V (10 k)
R115	7030003520	S.RES ERJ3GEYJ 472 V (4.7 k)
R116	7030003430	S.RES ERJ3GEYJ 821 V (820)
R117	7030003420	S.RES ERJ3GEYJ 681 V (680)
R118	7030003460	S.RES ERJ3GEYJ 152 V (1.5 k)
R119	7030003420	S.RES ERJ3GEYJ 681 V (680)
R120	7030003460	S.RES ERJ3GEYJ 152 V (1.5 k)
R121	7030003470	S.RES ERJ3GEYJ 182 V (1.8 k)
R122	7030003420	S.RES ERJ3GEYJ 681 V (680)
R123	7030003390	S.RES ERJ3GEYJ 391 V (390)
R124	7030003390	S.RES ERJ3GEYJ 391 V (390)
R125	7030003390	S.RES ERJ3GEYJ 391 V (390)
R126	7030003390	S.RES ERJ3GEYJ 391 V (390)
R127	7030003390	S.RES ERJ3GEYJ 391 V (390)
R128	7030003390	S.RES ERJ3GEYJ 391 V (390)
R129	7030003390	S.RES ERJ3GEYJ 391 V (390)
R130	7030003390	S.RES ERJ3GEYJ 391 V (390)
R131	7030003450	S.RES ERJ3GEYJ 122 V (1.2 k)
R132	7030003450	S.RES ERJ3GEYJ 122 V (1.2 k)
R133	7030003450	S.RES ERJ3GEYJ 122 V (1.2 k)
R134	7030003450	S.RES ERJ3GEYJ 122 V (1.2 k)
R135	7030003450	S.RES ERJ3GEYJ 122 V (1.2 k)
R136	7030003450	S.RES ERJ3GEYJ 122 V (1.2 k)
R137	7030003450	S.RES ERJ3GEYJ 122 V (1.2 k)
R138	7030003450	S.RES ERJ3GEYJ 122 V (1.2 k)
R140	7030003430	S.RES ERJ3GEYJ 821 V (820)
R141	7030003430	S.RES ERJ3GEYJ 821 V (820)
R142	7030003680	S.RES ERJ3GEYJ 104 V (100 k)
C1	4030006880	S.CER C1608 JB 1H 472K-T
C2	4030006880	S.CER C1608 JB 1H 472K-T
C4	4030006880	S.CER C1608 JB 1H 472K-T
C5	4030012610	S.CER C2012 JB 1C 474K-T
C7	4030006880	S.CER C1608 JB 1H 472K-T
C8	4030006880	S.CER C1608 JB 1H 472K-T
C9	4030006880	S.CER C1608 JB 1H 472K-T
C10	4030007020	S.CER C1608 CH 1H 120J-T
C11	4030007020	S.CER C1608 CH 1H 120J-T
C12	4030011600	S.CER C1608 JB 1E 104K-T
C13	4030011600	S.CER C1608 JB 1E 104K-T
C14	4030011600	S.CER C1608 JB 1E 104K-T
C15	4030006860	S.CER C1608 JB 1H 102K-T
C16	4030006860	S.CER C1608 JB 1H 102K-T
C18	4030015170	S.CER C3216 JB 0J 475M-T
C19	4030011600	S.CER C1608 JB 1E 104K-T
C20	4030015170	S.CER C3216 JB 0J 475M-T
C21	4550002980	S.TAN TEESVA 1C 225M8R

S.=Surface mount

[DISPLAY UNIT]

REF NO.	ORDER NO.	DESCRIPTION
C22	4030011600	S.CER C1608 JB 1E 104K-T
C23	4030011600	S.CER C1608 JB 1E 104K-T
C24	4550002980	S.TAN TEESVA 1C 225M8R
C25	4030011600	S.CER C1608 JB 1E 104K-T
C26	4030011600	S.CER C1608 JB 1E 104K-T
C27	4550002980	S.TAN TEESVA 1C 225M8R
C28	4550002980	S.TAN TEESVA 1C 225M8R
C29	4030011600	S.CER C1608 JB 1E 104K-T
C30	4030006880	S.CER C1608 JB 1H 472K-T
C31	4030006880	S.CER C1608 JB 1H 472K-T
C32	4030006880	S.CER C1608 JB 1H 472K-T
C33	4030006880	S.CER C1608 JB 1H 472K-T
C34	4030006850	S.CER C1608 JB 1H 471K-T
C35	4030006860	S.CER C1608 JB 1H 102K-T
C36	4030006860	S.CER C1608 JB 1H 102K-T
C37	4030011600	S.CER C1608 JB 1E 104K-T
C38	4030008890	S.CER C1608 JB 1H 273K-T
C39	4030011600	S.CER C1608 JB 1E 104K-T
C40	4030011600	S.CER C1608 JB 1E 104K-T
C41	4030011600	S.CER C1608 JB 1E 104K-T
C42	4030006880	S.CER C1608 JB 1H 472K-T
J1	6510019121	S.CNR S8B-PH-SM4-TB (LF) (SN)
J2	6450001630	CNR HSJ1406-01-050
J3	6510018891	S.CNR 52559-1370 (1390)
DS1	5040002020	S.LED CL-170UR-CD-T
DS2	5040002010	S.LED CL-170PG-CD-T
DS3	5040002020	S.LED CL-170UR-CD-T
DS4	5030001670	LCD DLC-8309YBGF
DS5	5030001290	LED D2264
S1	2260002250	S.SW LS22BB-2SD-PG-T
S2	2260002250	S.SW LS22BB-2SD-PG-T
S3	2260002540	S.SW SKQHFC
S4	2260002540	S.SW SKQHFC
S5	2260002540	S.SW SKQHFC
S6	2260002540	S.SW SKQHFC
S7	2260002540	S.SW SKQHFC
S8	2260002540	S.SW SKQHFC
S9	2260002540	S.SW SKQHFC
S10	2260002540	S.SW SKQHFC
S11	2260002550	S.SW SKQHFFH
S12	2260002550	S.SW SKQHFFH
S13	2260002250	S.SW LS22BB-2SD-PG-T
S14	2260001680	S.SW SKQDPB
W1	7030003860	S.RES ERJ3GE JPW V
W2	7120000470	JMP ERDS2T0
W3	7120000470	JMP ERDS2T0
EP2	8930039790	LCT SRCN-1691-ZSS-505

[MAIN UNIT]

REF NO.	ORDER NO.	DESCRIPTION
IC151	1110003970	S.IC uPC1658G-E1
IC221	1110004101	S.IC TA4001F (TE85L,F)
IC222	1110004091	S.IC TA4002F (TE85L,F)
IC231	1110004080	S.IC uPC2709T-E3
IC281	1110004080	S.IC uPC2709T-E3
IC351	1160000161	S.IC TD62783AFNG (5,S,EL)
IC521	1110003310	S.IC uPC1688G-T1
IC571	1110003960	S.IC uPC2713T-E3
IC631	1110003141	IC LA1150N-E
IC791	1110003491	S.IC TA31136FNG (D,EL)
IC811	1110003780	S.IC NJM2902V-TE1
IC841	1110004870	S.IC TA4101F (TE12L,F)
IC861	1130009100	S.IC BU4052BCFV-E2
IC891	1110003780	S.IC NJM2902V-TE1
IC931	1140005281	S.IC uPC5023GS-077-E1-A
IC971	1130006221	S.IC TC4W53FU (TE12L,F)
IC981	1110003870	S.IC NJM2058M-TE1
IC1011	1130007661	S.IC LC7153M-TLM-E
IC1041	1110004840	S.IC NJM1496V-TE1
IC1091	1110003780	S.IC NJM2902V-TE1
IC1141	1130009100	S.IC BU4052BCFV-E2
IC2001	1140008301	S.IC HD643337YA61FV (SX-2177)
	1140009941	S.IC HD64F3337YF16V (SX-2177B)
IC2101	1130009100	S.IC BU4052BCFV-E2
IC2121	1130011281	S.IC CAT25C64V1-TE13
IC2122	1130007111	S.IC TC7W04FU (TE12L,F)
IC2131	1130003761	S.IC TC4S81F (TE85R,F)
IC2161	1110005771	S.IC S-80942CNMC-G9CT2G
IC2201	1110004310	S.IC M62352GP 75EC
IC2202	1110003780	S.IC NJM2902V-TE1
IC2221	1130007570	S.IC BU4094BCFV-E2
IC2222	1130007570	S.IC BU4094BCFV-E2
IC2231	1130005491	S.IC TC74HC4094AF (F)
IC2232	1130007570	S.IC BU4094BCFV-E2
IC2241	1160000131	S.IC TD62783AFG (S,EL)
Q111	1590002310	S.TR DTC114EE TL
Q112	1590002310	S.TR DTC114EE TL
Q121	1590002310	S.TR DTC114EE TL
Q122	1590001870	S.TR DTA114EE TL
Q131	1590002310	S.TR DTC114EE TL
Q132	1590002310	S.TR DTC114EE TL
Q133	1590001870	S.TR DTA114EE TL
Q151	1590002310	S.TR DTC114EE TL
Q271	1590001330	S.TR DTA114EUA T106
Q351	1590002480	S.TR UMC3N TR
Q352	1590002480	S.TR UMC3N TR
Q353	1590002480	S.TR UMC3N TR
Q354	1590002480	S.TR UMC3N TR
Q521	1590002310	S.TR DTC114EE TL
Q522	1590002310	S.TR DTC114EE TL
Q571	1590002310	S.TR DTC114EE TL
Q572	1530002060	S.TR 2SC4081 T106 R
Q573	1530002060	S.TR 2SC4081 T106 R
Q601	1530002060	S.TR 2SC4081 T106 R
Q611	1530002060	S.TR 2SC4081 T106 R
Q621	1560000561	S.FET 2SK882-GR (TE85L,F)
Q631	1510000510	S.TR 2SA1576A T106R
Q632	1560000561	S.FET 2SK882-GR (TE85L,F)
Q633	1530002060	S.TR 2SC4081 T106 R
Q634	1530002060	S.TR 2SC4081 T106 R
Q635	1590002310	S.TR DTC114EE TL
Q636	1590001330	S.TR DTA114EUA T106
Q721	1530002060	S.TR 2SC4081 T106 R
Q731	1580000601	S.FET 3SK126-O (TE85R,F)
Q732	1590002480	S.TR UMC3N TR
Q741	1560000561	S.FET 2SK882-GR (TE85L,F)
Q751	1530002060	S.TR 2SC4081 T106 R
Q771	1530002060	S.TR 2SC4081 T106 R
Q772	1590002760	S.TR UMC1NTR
Q773	1590002760	S.TR UMC1NTR
Q774	1530002060	S.TR 2SC4081 T106 R
Q776	1530002060	S.TR 2SC4081 T106 R
Q777	1510000510	S.TR 2SA1576A T106R
Q921	1590002310	S.TR DTC114EE TL
Q961	1530002060	S.TR 2SC4081 T106 R
Q981	1590002310	S.TR DTC114EE TL
Q982	1590002310	S.TR DTC114EE TL
Q1011	1560000331	S.FET 2SK210-GR (TE85R,F)
Q1012	1590002310	S.TR DTC114EE TL
Q1013	1530002060	S.TR 2SC4081 T106 R
Q1041	1590002310	S.TR DTC114EE TL
Q1061	1510000510	S.TR 2SA1576A T106R
Q1062	1530002060	S.TR 2SC4081 T106 R
Q1071	1590002310	S.TR DTC114EE TL
Q1072	1590002310	S.TR DTC114EE TL
Q1073	1590002310	S.TR DTC114EE TL
Q1074	1590002310	S.TR DTC114EE TL
Q1075	1590002310	S.TR DTC114EE TL
Q1091	1590002310	S.TR DTC114EE TL
Q1092	1530002060	S.TR 2SC4081 T106 R
Q1101	1590002310	S.TR DTC114EE TL
Q1131	1510000510	S.TR 2SA1576A T106R
Q2001	1590001870	S.TR DTA114EE TL
Q2131	1590002310	S.TR DTC114EE TL
Q2141	1590002310	S.TR DTC114EE TL
Q2171	1510000510	S.TR 2SA1576A T106R
Q2172	1530002060	S.TR 2SC4081 T106 R
Q2221	1590002480	S.TR UMC3N TR
Q2222	1590002480	S.TR UMC3N TR
Q2223	1590002480	S.TR UMC3N TR
Q2224	1590002480	S.TR UMC3N TR
Q2225	1590002480	S.TR UMC3N TR

[Others]  
[ITR]

S.=Surface mount



[MAIN UNIT]

REF NO.	ORDER NO.	DESCRIPTION
Q2226	1590002310	S.TR DTC114EE TL
Q2227	1590002310	S.TR DTC114EE TL
D111	1750000641	S.DIO 1SV312 (TE85L,F)
D112	1750000641	S.DIO 1SV312 (TE85L,F)
D123	1790001250	S.DIO MA2S111-(TX)
D131	1790001621	S.DIO 1SV308 (TPL3,F)
D132	1790001611	S.DIO 1SS385 (TE85L,F)
D133	1790001250	S.DIO MA2S111-(TX)
D141	1790001621	S.DIO 1SV308 (TPL3,F)
D142	1750000641	S.DIO 1SV312 (TE85L,F)
D143	1790001621	S.DIO 1SV308 (TPL3,F)
D151	1790001621	S.DIO 1SV308 (TPL3,F)
D152	1790001621	S.DIO 1SV308 (TPL3,F)
D153	1790001621	S.DIO 1SV308 (TPL3,F)
D222	1750000641	S.DIO 1SV312 (TE85L,F)
D224	1790001621	S.DIO 1SV308 (TPL3,F)
D251	1790001621	S.DIO 1SV308 (TPL3,F)
D252	1790001621	S.DIO 1SV308 (TPL3,F)
D261	1790001621	S.DIO 1SV308 (TPL3,F)
D262	1790001621	S.DIO 1SV308 (TPL3,F)
D271	1750000431	S.DIO HSB88WSTR-E
D272	1790001621	S.DIO 1SV308 (TPL3,F)
D273	1790001621	S.DIO 1SV308 (TPL3,F)
D274	1790001621	S.DIO 1SV308 (TPL3,F)
D275	1790001621	S.DIO 1SV308 (TPL3,F)
D276	1790001621	S.DIO 1SV308 (TPL3,F)
D351	1750000520	S.DIO DAN222TL
D352	1750000520	S.DIO DAN222TL
D500	1790001621	S.DIO 1SV308 (TPL3,F)
D501	1790001621	S.DIO 1SV308 (TPL3,F)
D502	1790000450	S.DIO MA862 (TX)
D521	1750000971	S.DIO CPH5513-TL-E
D522	1750000971	S.DIO CPH5513-TL-E
D551	1750000431	S.DIO HSB88WSTR-E
D552	1790000450	S.DIO MA862 (TX)
D561	1790000450	S.DIO MA862 (TX)
D562	1790000450	S.DIO MA862 (TX)
D571	1790001260	S.DIO MA2S077-(TX)
D572	1750000971	S.DIO CPH5513-TL-E
D573	1750000971	S.DIO CPH5513-TL-E
D574	1790001250	S.DIO MA2S111-(TX)
D621	1790000450	S.DIO MA862 (TX)
D622	1790001250	S.DIO MA2S111-(TX)
D631	1750000520	S.DIO DAN222TL
D632	1790001211	S.DIO 1SS375-TL-E
D633	1790001250	S.DIO MA2S111-(TX)
D634	1790001250	S.DIO MA2S111-(TX)
D671	1790000450	S.DIO MA862 (TX)
D672	1790000450	S.DIO MA862 (TX)
D681	1790000450	S.DIO MA862 (TX)
D682	1790000450	S.DIO MA862 (TX)
D683	1790001250	S.DIO MA2S111-(TX)
D691	1790000450	S.DIO MA862 (TX)
D692	1790000450	S.DIO MA862 (TX)
D701	1790000450	S.DIO MA862 (TX)
D702	1790000450	S.DIO MA862 (TX)
D711	1790000450	S.DIO MA862 (TX)
D712	1790000450	S.DIO MA862 (TX)
D721	1790000450	S.DIO MA862 (TX)
D761	1790001211	S.DIO 1SS375-TL-E
D771	1790001211	S.DIO 1SS375-TL-E
D772	1790001250	S.DIO MA2S111-(TX)
D791	1790000450	S.DIO MA862 (TX)
D861	1790001240	S.DIO MA2S728-(TX)
D921	1750000520	S.DIO DAN222TL
D923	1790001250	S.DIO MA2S111-(TX)
D931	1750000370	S.DIO DA221 TL
D932	1750000370	S.DIO DA221 TL
D981	1790001611	S.DIO 1SS385 (TE85L,F)
D1011	1790001250	S.DIO MA2S111-(TX)
D1012	1720000590	S.VCP MA357 (TX)
D1013	1790001211	S.DIO 1SS375-TL-E
D1014	1790001211	S.DIO 1SS375-TL-E
D1041	1790001250	S.DIO MA2S111-(TX)
D1042	1790000450	S.DIO MA862 (TX)
D1061	1730002510	S.ZEN MA8027-H (TX)
D1071	1790001250	S.DIO MA2S111-(TX)
D1072	1790001240	S.DIO MA2S728-(TX)
D1073	1790001240	S.DIO MA2S728-(TX)
D1074	1790001611	S.DIO 1SS385 (TE85L,F)
D1075	1790001250	S.DIO MA2S111-(TX)
D1076	1790001040	S.ZEN MA8033-L (TX)
D1077	1790001040	S.ZEN MA8033-L (TX)
D1078	1790001240	S.DIO MA2S728-(TX)
D1091	1160000140	S.DIO DAP222 TL
D1111	1790001611	S.DIO 1SS385 (TE85L,F)
D1112	1790001611	S.DIO 1SS385 (TE85L,F)
D1113	1160000140	S.DIO DAP222 TL
D1114	1790001611	S.DIO 1SS385 (TE85L,F)
D1131	1790001330	S.ZEN MA8036-L (TX)
D1132	1160000140	S.DIO DAP222 TL
D1161	1790001611	S.DIO 1SS385 (TE85L,F)
D2001	1750000370	S.DIO DA221 TL
D2002	1750000370	S.DIO DA221 TL
D2025	1790001250	S.DIO MA2S111-(TX) [ESP], [ITR], [EUR-1], [ESP-1], [ITR-1] only
D2026	1790001250	S.DIO MA2S111-(TX) [FRA], [ITR], [FRA-1], [ITR-1] only
D2027	1790001250	S.DIO MA2S111-(TX) [EUR], [ESP], [EUR-1], [ESP-1] only
D2029	1790001250	S.DIO MA2S111-(TX) [ESP], [ITR], [ESP-1], [ITR-1] only
D2030	1790001250	S.DIO MA2S111-(TX)
D2031	1790001250	S.DIO MA2S111-(TX)
D2081	1790001250	S.DIO MA2S111-(TX)

[MAIN UNIT]

REF NO.	ORDER NO.	DESCRIPTION
D2082	1790001250	S.DIO MA2S111-(TX)
D2083	1790001250	S.DIO MA2S111-(TX)
D2101	1790001250	S.DIO MA2S111-(TX)
D2102	1790001250	S.DIO MA2S111-(TX)
D2103	1790001250	S.DIO MA2S111-(TX)
D2104	1790001250	S.DIO MA2S111-(TX)
D2105	1790001250	S.DIO MA2S111-(TX)
D2106	1790001250	S.DIO MA2S111-(TX)
D2107	1790001250	S.DIO MA2S111-(TX)
D2108	1790001611	S.DIO 1SS385 (TE85L,F)
D2131	1750000370	S.DIO DA221 TL
D2132	1750000370	S.DIO DA221 TL
D2133	1750000520	S.DIO DAN222TL
D2141	1750000370	S.DIO DA221 TL
D2142	1750000370	S.DIO DA221 TL
D2143	1750000370	S.DIO DA221 TL
D2144	1790001250	S.DIO MA2S111-(TX)
D2145	1790001250	S.DIO MA2S111-(TX)
D2161	1790001250	S.DIO MA2S111-(TX)
D2171	1790001250	S.DIO MA2S111-(TX)
D2181	1730000911	S.ZEN RD12M-T2B-A B2
D2182	1790001621	S.DIO 1SV308 (TPL3,F)
D2183	1790001621	S.DIO 1SV308 (TPL3,F)
FI371	2040001420	S.LC LFB32440MSC1-955 (LFSC25N12B0)
FI372	2040001420	S.LC LFB32440MSC1-955 (LFSC25N12B0)
FI373	2040001420	S.LC LFB32440MSC1-955 (LFSC25N12B0)
FI511	2010002090	FIL FL-261 (69.0115 MHz)
FI561	2010000270	FIL 9M15A (FL-23)
FI601	2020001810	S.CER SFECV10M7FA00-R0 (SFECV10.7MA5S) [ESP], [OTH], [ITA], [ITR], [OTH-1], [ITR-1], [CHN], [CHN-01] only
FI611	2020001810	S.CER SFECV10M7FA00-R0 (SFECV10.7MA5S) [ESP], [OTH], [ITA], [ITR], [OTH-1], [ITR-1], [CHN], [CHN-01] only
FI671	2010002130	D.FIL FL-272 (9.0115 MHz)
FI681	2010000730	FIL 9M 8A (FL-94)
FI791	2020001051	S.CER SFPKA455KE4A-R1
X791	6070000151	S.DCR CDBKB455KCAY24-R0
X2161	6050010501	S.XTL CR-636A (14.7456 MHz)
L111	6200003550	S.COL MLF1608A 4R7K-T
L112	6200008070	S.COL MLF1608E 6R8K 6.8U
L121	6200012340	S.COL LB2518T101K
L122	6200003550	S.COL MLF1608A 4R7K-T
L123	6200003941	S.COL NLV25T-5R6J
L132	6200002631	S.COL NLV25T-R10J
L133	6200002641	S.COL NLV25T-R15J
L141	6200012340	S.COL LB2518T101K
L142	6200003550	S.COL MLF1608A 4R7K-T
L151	6200012340	S.COL LB2518T101K
L153	6200012340	S.COL LB2518T101K
L154	6200012340	S.COL LB2518T101K
L155	6200012340	S.COL LB2518T101K
L156	6200012340	S.COL LB2518T101K
L158	6200003640	S.COL MLF1608E 100K-T
L159	6200003640	S.COL MLF1608E 100K-T
L182	6200002520	S.COL ELJNC R18K-F
L183	6200002520	S.COL ELJNC R18K-F
L184	6200002520	S.COL ELJNC R18K-F
L195	6200006671	S.COL ELJRE 68NGFA
L196	6200006991	S.COL ELJRE 56NGFA
L231	6200001711	S.COL NLV32T-220J
L232	6200004480	S.COL MLF1608D R82K-T
L233	6200004961	S.COL NLV25T-R33J
L251	6200012680	S.COL 0.30-1.3-5TL 20N <COMO>
L252	6200012680	S.COL 0.30-1.3-5TL 20N <COMO>
L253	6200012960	S.COL 0.45-1.4-4TL 12.1N <COMO>
L254	6200012340	S.COL LB2518T101K
L255	6200012340	S.COL LB2518T101K
L256	6200012340	S.COL LB2518T101K
L257	6200012340	S.COL LB2518T101K
L261	6200007720	S.COL LQW2BHN33NJ03L
L262	6200007740	S.COL LQW2BHN47NJ03L
L271	6130002961	S.COL #617DB-1327=P3
L272	6130002961	S.COL #617DB-1327=P3
L273	6200004920	S.COL MLF1608A 2R2K-T
L280	6200007700	S.COL LQW2BHN22NJ03L except [EUR], [FRA], [ESP], [USA], [EUR-1], [ESP-1], [USA-1]
L281	6200004590	S.COL MLF1608D R18K-T
L344	6200002971	S.COL NLV32T-121J
L371	6200005691	S.COL ELJRE 18NGFA
L372	6200005691	S.COL ELJRE 18NGFA
L417	6200003550	S.COL MLF1608A 4R7K-T
L435	6200003550	S.COL MLF1608A 4R7K-T
L464	6200003550	S.COL MLF1608A 4R7K-T
L477	6200003550	S.COL MLF1608A 4R7K-T
L501	6200005190	S.COL MLF1608D R56K-T
L502	6200009540	S.COL MLG1608B 22NJ-T [OTH], [ITA], [ITR], [OTH-1], [ITR-1], [CHN], [CHN-01] only
L503	6200005190	S.COL MLF1608D R56K-T
L504	6200004940	S.COL MLF1608D R27K-T
L505	6200009550	S.COL MLG1608B 27NJ-T [OTH], [ITA], [ITR], [OTH-1], [ITR-1], [CHN], [CHN-01] only
L511	6150004971	S.COL LS-522-LF
L512	6150004971	S.COL LS-522-LF
L513	6200002991	S.COL NLV32T-2R2J
L521	6200002991	S.COL NLV32T-2R2J
L522	6200002991	S.COL NLV32T-2R2J
L523	6200002991	S.COL NLV32T-2R2J
L524	6200002991	S.COL NLV32T-2R2J
L525	6200002991	S.COL NLV32T-2R2J

S.=Surface mount



[MAIN UNIT]

REF NO.	ORDER NO.	DESCRIPTION
L526	6200002991	S.COL NLV32T-2R2J
L527	6200001831	S.COL NLV32T-100J
L528	6200001831	S.COL NLV32T-100J
L529	6200002991	S.COL NLV32T-2R2J
L541	6200003540	S.COL MLF1608D R22K-T
L542	6200007700	S.COL LQW2BHN22N.J03L
L543	6200005180	S.COL MLF1608D R39K-T
L544	6200004600	S.COL MLF1608D R15K-T
L545	6200007700	S.COL LQW2BHN22N.J03L
L546	6200004720	S.COL MLF1608D R10K-T
L551	6140002810	S.COL LR-317
L552	6140002810	S.COL LR-317
L561	6200004600	S.COL MLF1608D R15K-T
L562	6150004871	S.COL LS-512-LF
L563	6150004871	S.COL LS-512-LF
L564	6200004600	S.COL MLF1608D R15K-T
L565	6200004600	S.COL MLF1608D R15K-T
L566	6150004901	S.COL LS-515-LF
L571	6200002900	S.COL ELJSC 680K-F
L572	6200002900	S.COL ELJSC 680K-F
L573	6200003261	S.COL NLV32T-101J
L574	6200002041	S.COL NLV25T-101J
L575	6200003261	S.COL NLV32T-101J
L576	6200003261	S.COL NLV32T-101J
L577	6200003261	S.COL NLV32T-101J
L578	6200003261	S.COL NLV32T-101J
L579	6200001851	S.COL NLV32T-5R6J
L601	6200003031	S.COL NLV32T-R47J
L602	6200003261	S.COL NLV32T-101J
L603	6200003261	S.COL NLV32T-101J
L621	6150004881	S.COL LS-513-LF
L622	6200002041	S.COL NLV25T-101J
L631	6200003191	S.COL NLV32T-470J
L632	6150004891	S.COL LS-514-LF
L633	6150004881	S.COL LS-513-LF
L634	6200003261	S.COL NLV32T-101J
L671	6200003121	S.COL NLV32T-8R2J
L681	6200001711	S.COL NLV32T-220J
L682	6200001831	S.COL NLV32T-100J
L701	6200007380	S.COL ELJFC 8R2K-F
L711	6200007380	S.COL ELJFC 8R2K-F except [USA], [USA-1], [EUR], [EUR-1] except [USA], [USA-1], [EUR], [EUR-1]
L731	6150004911	S.COL LS-516-LF
L741	6150004911	S.COL LS-516-LF
L791	6200003261	S.COL NLV32T-101J
L841	6200003261	S.COL NLV32T-101J
L1011	6200003261	S.COL NLV32T-101J
L1012	6200003261	S.COL NLV32T-101J
L1013	6200002991	S.COL NLV32T-2R2J
L1014	6200001831	S.COL NLV32T-100J
L1015	6200008600	S.COL ELJFC 560K-F
L1041	6200002041	S.COL NLV25T-101J
L1042	6200002041	S.COL NLV25T-101J
L1043	6200002041	S.COL NLV25T-101J
L1044	6200003261	S.COL NLV32T-101J
L2001	6200001831	S.COL NLV32T-100J
L2251	6200003950	S.COL HF50ACC 322513-T
L2252	6200003950	S.COL HF50ACC 322513-T
L2253	6200003640	S.COL MLF1608E 100K-T
L2254	6200005190	S.COL MLF1608D R56K-T
R111	7030003310	S.RES ERJ3GEYJ 820 V (82)
R112	7030003320	S.RES ERJ3GEYJ 101 V (100)
R113	7030003360	S.RES ERJ3GEYJ 221 V (220)
R114	7030003720	S.RES ERJ3GEYJ 224 V (220 k)
R115	7030000300	S.RES MCR10EZHZJ 220 (221)
R116	7030000300	S.RES MCR10EZHZJ 220 (221)
R117	7030003320	S.RES ERJ3GEYJ 101 V (100)
R120	7030003340	S.RES ERJ3GEYJ 151 V (150)
R121	7030003350	S.RES ERJ3GEYJ 181 V (180)
R122	7030003470	S.RES ERJ3GEYJ 182 V (1.8 k) [ESP], [OTH], [ITA], [ITR], [OTH-1], [ITR-1], [CHN], [CHN-01] only
R123	7030003720	S.RES ERJ3GEYJ 224 V (220 k)
R124	7030003560	S.RES ERJ3GEYJ 103 V (10 k)
R125	7030003470	S.RES ERJ3GEYJ 182 V (1.8 k) [ESP], [OTH], [ITA], [ITR], [OTH-1], [ITR-1], [CHN], [CHN-01] only
R126	7030003470	S.RES ERJ3GEYJ 182 V (1.8 k) [ESP], [OTH], [ITA], [ITR], [OTH-1], [ITR-1], [CHN], [CHN-01] only
R131	7030003720	S.RES ERJ3GEYJ 224 V (220 k)
R132	7030003720	S.RES ERJ3GEYJ 224 V (220 k)
R133	7030009220	S.RES ERJ12VJ561U
R134	7030003370	S.RES ERJ3GEYJ 271 V (270)
R135	7030003560	S.RES ERJ3GEYJ 103 V (10 k)
R141	7030003720	S.RES ERJ3GEYJ 224 V (220 k)
R142	7030003720	S.RES ERJ3GEYJ 224 V (220 k)
R143	7030003470	S.RES ERJ3GEYJ 182 V (1.8 k) [ESP], [OTH], [ITA], [ITR], [OTH-1], [ITR-1], [CHN], [CHN-01] only
R144	7030003470	S.RES ERJ3GEYJ 182 V (1.8 k) [ESP], [OTH], [ITA], [ITR], [OTH-1], [ITR-1], [CHN], [CHN-01] only
R145	7030003470	S.RES ERJ3GEYJ 182 V (1.8 k) [ESP], [OTH], [ITA], [ITR], [OTH-1], [ITR-1], [CHN], [CHN-01] only
R151	7030003360	S.RES ERJ3GEYJ 221 V (220)
R153	7030003340	S.RES ERJ3GEYJ 151 V (150)
R154	7030003400	S.RES ERJ3GEYJ 471 V (470)
R155	7030003430	S.RES ERJ3GEYJ 821 V (820)
R156	7030003350	S.RES ERJ3GEYJ 181 V (180)
R157	7030003400	S.RES ERJ3GEYJ 471 V (470)
R158	7030003720	S.RES ERJ3GEYJ 224 V (220 k)
R159	7030003200	S.RES ERJ3GEYJ 100 V (10)
R160	7030003370	S.RES ERJ3GEYJ 271 V (270)
R161	7030003230	S.RES ERJ3GEYJ 180 V (18)
R162	7030003370	S.RES ERJ3GEYJ 271 V (270)

[MAIN UNIT]

REF NO.	ORDER NO.	DESCRIPTION
R163	7030003360	S.RES ERJ3GEYJ 221 V (220)
R164	7030003280	S.RES ERJ3GEYJ 470 V (47)
R165	7030003360	S.RES ERJ3GEYJ 221 V (220)
R174	7030003360	S.RES ERJ3GEYJ 221 V (220)
R181	7030000340	S.RES MCR10EZHZJ 470 (471)
R200	7030003350	S.RES ERJ3GEYJ 181 V (180)
R201	7030003370	S.RES ERJ3GEYJ 271 V (270)
R202	7030003340	S.RES ERJ3GEYJ 151 V (150)
R203	7030003200	S.RES ERJ3GEYJ 100 V (10)
R204	7030003340	S.RES ERJ3GEYJ 151 V (150)
R223	7030003220	S.RES ERJ3GEYJ 150 V (15)
R224	7030003320	S.RES ERJ3GEYJ 101 V (100)
R224	7030003370	S.RES ERJ3GEYJ 271 V (270)
R225	7030003280	S.RES ERJ3GEYJ 470 V (47)
R232	7030003400	S.RES ERJ3GEYJ 471 V (470)
R234	7030003200	S.RES ERJ3GEYJ 100 V (10)
R236	7030003370	S.RES ERJ3GEYJ 271 V (270)
R237	7030003230	S.RES ERJ3GEYJ 180 V (18)
R238	7030003370	S.RES ERJ3GEYJ 271 V (270)
R251	7030000300	S.RES MCR10EZHZJ 220 (221)
R252	7030003360	S.RES ERJ3GEYJ 221 V (220)
R253	7030003360	S.RES ERJ3GEYJ 221 V (220)
R271	7030000300	S.RES MCR10EZHZJ 220 (221)
R272	7030003440	S.RES ERJ3GEYJ 102 V (1 k) except [USA], [USA-1], [EUR], [EUR-1]
R273	7030003440	S.RES ERJ3GEYJ 102 V (1 k) except [USA], [USA-1], [EUR], [EUR-1]
R274	7030003440	S.RES ERJ3GEYJ 102 V (1 k)
R275	7030003440	S.RES ERJ3GEYJ 102 V (1 k)
R276	7030003440	S.RES ERJ3GEYJ 102 V (1 k)
R277	7030003440	S.RES ERJ3GEYJ 102 V (1 k)
R278	7030003560	S.RES ERJ3GEYJ 103 V (10 k)
R279	7030003440	S.RES ERJ3GEYJ 102 V (1 k)
R280	7030003380	S.RES ERJ3GEYJ 331 V (330)
R281	7030003350	S.RES ERJ3GEYJ 181 V (180)
R282	7030003260	S.RES ERJ3GEYJ 330 V (33)
R283	7030003350	S.RES ERJ3GEYJ 181 V (180)
R284	7030003200	S.RES ERJ3GEYJ 100 V (10)
R285	7030003400	S.RES ERJ3GEYJ 471 V (470)
R286	7030003200	S.RES ERJ3GEYJ 100 V (10)
R288	7030003500	S.RES ERJ3GEYJ 332 V (3.3 k)
R340	7030003560	S.RES ERJ3GEYJ 103 V (10 k)
R341	7030003560	S.RES ERJ3GEYJ 103 V (10 k)
R342	7030003560	S.RES ERJ3GEYJ 103 V (10 k)
R343	7030003560	S.RES ERJ3GEYJ 103 V (10 k)
R351	7030003560	S.RES ERJ3GEYJ 103 V (10 k)
R352	7030003560	S.RES ERJ3GEYJ 103 V (10 k)
R353	7030003560	S.RES ERJ3GEYJ 103 V (10 k)
R354	7030003560	S.RES ERJ3GEYJ 103 V (10 k)
R355	7030003560	S.RES ERJ3GEYJ 103 V (10 k)
R356	7030003560	S.RES ERJ3GEYJ 103 V (10 k)
R357	7030003560	S.RES ERJ3GEYJ 103 V (10 k)
R358	7030003560	S.RES ERJ3GEYJ 103 V (10 k)
R359	7030003560	S.RES ERJ3GEYJ 103 V (10 k)
R501	7030003440	S.RES ERJ3GEYJ 102 V (1 k)
R502	7030003440	S.RES ERJ3GEYJ 102 V (1 k)
R503	7030003400	S.RES ERJ3GEYJ 471 V (470)
R504	7030003230	S.RES ERJ3GEYJ 180 V (18) [OTH], [ITA], [ITR], [OTH-1], [ITR-1], [CHN], [CHN-01] only
R511	7030003440	S.RES ERJ3GEYJ 102 V (1 k)
R512	7030003440	S.RES ERJ3GEYJ 102 V (1 k)
R513	7030003380	S.RES ERJ3GEYJ 331 V (330)
R514	7030003400	S.RES ERJ3GEYJ 471 V (470)
R521	7030003280	S.RES ERJ3GEYJ 470 V (47)
R522	7030003280	S.RES ERJ3GEYJ 470 V (47)
R523	7030003320	S.RES ERJ3GEYJ 101 V (100)
R524	7030003360	S.RES ERJ3GEYJ 221 V (220)
R525	7030003360	S.RES ERJ3GEYJ 221 V (220)
R526	7030003360	S.RES ERJ3GEYJ 221 V (220)
R527	7030003350	S.RES ERJ3GEYJ 181 V (180)
R527	7030003360	S.RES ERJ3GEYJ 221 V (220)
R528	7030003360	S.RES ERJ3GEYJ 221 V (220)
R551	7030003370	S.RES ERJ3GEYJ 271 V (270)
R552	7030003230	S.RES ERJ3GEYJ 180 V (18)
R553	7030003370	S.RES ERJ3GEYJ 271 V (270)
R554	7030003400	S.RES ERJ3GEYJ 471 V (470)
R561	7030003280	S.RES ERJ3GEYJ 470 V (47)
R562	7030003360	S.RES ERJ3GEYJ 221 V (220)
R563	7030003360	S.RES ERJ3GEYJ 221 V (220)
R564	7030003280	S.RES ERJ3GEYJ 470 V (47)
R571	7030003520	S.RES ERJ3GEYJ 472 V (4.7 k)
R572	7030003480	S.RES ERJ3GEYJ 222 V (2.2 k)
R573	7030003360	S.RES ERJ3GEYJ 221 V (220)
R574	7030003360	S.RES ERJ3GEYJ 221 V (220)
R576	7030003360	S.RES ERJ3GEYJ 221 V (220)
R577	7030003360	S.RES ERJ3GEYJ 221 V (220)
R578	7030003320	S.RES ERJ3GEYJ 101 V (100)
R579	7310005110	S.TRI RH03ADCS2X (470)
R580	7030003320	S.RES ERJ3GEYJ 101 V (100)
R581	7030003360	S.RES ERJ3GEYJ 221 V (220)
R582	7030003400	S.RES ERJ3GEYJ 471 V (470)
R583	7030003360	S.RES ERJ3GEYJ 221 V (220)
R584	7030003400	S.RES ERJ3GEYJ 471 V (470)
R585	7030003440	S.RES ERJ3GEYJ 102 V (1 k)
R585	7030003520	S.RES ERJ3GEYJ 472 V (4.7 k)
R586	7030003500	S.RES ERJ3GEYJ 332 V (3.3 k)
R587	7030003320	S.RES ERJ3GEYJ 472 V (4.7 k)
R588	7030003640	S.RES ERJ3GEYJ 473 V (47 k)
R601	7030003440	S.RES ERJ3GEYJ 102 V (1 k)
R602	7030003570	S.RES ERJ3GEYJ 123 V (12 k)
R603	7030003480	S.RES ERJ3GEYJ 222 V (2.2 k)
R604	7030003380	S.RES ERJ3GEYJ 331 V (330)
R605	7030003280	S.RES ERJ3GEYJ 470 V (47)
R612	7030003540	S.RES ERJ3GEYJ 682 V (6.8 k)

S.=Surface mount

[MAIN UNIT]

REF NO.	ORDER NO.	DESCRIPTION
R613	7030003440	S.RES ERJ3GEYJ 102 V (1 k)
R614	7030003410	S.RES ERJ3GEYJ 561 V (560)
R615	7030003280	S.RES ERJ3GEYJ 470 V (47)
R616	7030003440	S.RES ERJ3GEYJ 102 V (1 k)
R617	7030003280	S.RES ERJ3GEYJ 470 V (47)
R618	7030003430	S.RES ERJ3GEYJ 821 V (820)
R619	7030003420	S.RES ERJ3GEYJ 681 V (680)
R621	7030003680	S.RES ERJ3GEYJ 104 V (100 k)
R622	7030003320	S.RES ERJ3GEYJ 101 V (100)
R623	7310005020	S.TRI RH03ADC14X (10 k)
R624	7030003620	S.RES ERJ3GEYJ 333 V (33 k)
R625	7030003520	S.RES ERJ3GEYJ 472 V (4.7 k)
R626	7030003320	S.RES ERJ3GEYJ 101 V (100)
R627	7030003400	S.RES ERJ3GEYJ 471 V (470)
R628	7030003400	S.RES ERJ3GEYJ 471 V (470)
R631	7030003640	S.RES ERJ3GEYJ 473 V (47 k)
R632	7030003480	S.RES ERJ3GEYJ 222 V (2.2 k)
R633	7030003720	S.RES ERJ3GEYJ 224 V (220 k)
R634	7030003360	S.RES ERJ3GEYJ 221 V (220)
R635	7030003520	S.RES ERJ3GEYJ 472 V (4.7 k)
R636	7030003320	S.RES ERJ3GEYJ 101 V (100)
R637	7030003640	S.RES ERJ3GEYJ 473 V (47 k)
R638	7030003520	S.RES ERJ3GEYJ 472 V (4.7 k)
R639	7030003680	S.RES ERJ3GEYJ 104 V (100 k)
R640	7030003540	S.RES ERJ3GEYJ 682 V (6.8 k)
R641	7030003500	S.RES ERJ3GEYJ 332 V (3.3 k)
R642	7030003380	S.RES ERJ3GEYJ 331 V (330)
R643	7030003600	S.RES ERJ3GEYJ 223 V (22 k)
R644	7030003440	S.RES ERJ3GEYJ 102 V (1 k)
R661	7030003560	S.RES ERJ3GEYJ 103 V (10 k)
R662	7030003560	S.RES ERJ3GEYJ 103 V (10 k)
R663	7030003560	S.RES ERJ3GEYJ 103 V (10 k)
R664	7030003560	S.RES ERJ3GEYJ 103 V (10 k)
R665	7030003560	S.RES ERJ3GEYJ 103 V (10 k)
R671	7030003480	S.RES ERJ3GEYJ 222 V (2.2 k)
R672	7030003480	S.RES ERJ3GEYJ 222 V (2.2 k)
R673	7030003360	S.RES ERJ3GEYJ 221 V (220)
R674	7030003560	S.RES ERJ3GEYJ 103 V (10 k)
R681	7030003480	S.RES ERJ3GEYJ 222 V (2.2 k)
R682	7030003480	S.RES ERJ3GEYJ 222 V (2.2 k)
R683	7030003360	S.RES ERJ3GEYJ 221 V (220)
R684	7030003560	S.RES ERJ3GEYJ 103 V (10 k)
R691	7030003480	S.RES ERJ3GEYJ 222 V (2.2 k)
R692	7030003480	S.RES ERJ3GEYJ 222 V (2.2 k)
R693	7030003560	S.RES ERJ3GEYJ 103 V (10 k)
R701	7030003480	S.RES ERJ3GEYJ 222 V (2.2 k)
R702	7030003480	S.RES ERJ3GEYJ 222 V (2.2 k)
R703	7030003360	S.RES ERJ3GEYJ 221 V (220)
R704	7030003560	S.RES ERJ3GEYJ 103 V (10 k)
R711	7030003480	S.RES ERJ3GEYJ 222 V (2.2 k)
R712	7030003480	S.RES ERJ3GEYJ 222 V (2.2 k)
R713	7030003360	S.RES ERJ3GEYJ 221 V (220)
R714	7030003560	S.RES ERJ3GEYJ 103 V (10 k)
R721	7030003320	S.RES ERJ3GEYJ 101 V (100)
R722	7030003530	S.RES ERJ3GEYJ 562 V (5.6 k)
R723	7030003420	S.RES ERJ3GEYJ 681 V (680)
R730	7030003570	S.RES ERJ3GEYJ 123 V (12 k)
R731	7030003580	S.RES ERJ3GEYJ 153 V (15 k)
R732	7030003590	S.RES ERJ3GEYJ 183 V (18 k)
R733	7030003400	S.RES ERJ3GEYJ 471 V (470)
R734	7030003280	S.RES ERJ3GEYJ 470 V (47)
R735	7030003400	S.RES ERJ3GEYJ 471 V (470)
R736	7030003280	S.RES ERJ3GEYJ 470 V (47)
R741	7310005050	S.TRI RH03ADCS3X (4.7 k)
R742	7030003280	S.RES ERJ3GEYJ 470 V (47)
R751	7030003400	S.RES ERJ3GEYJ 471 V (470)
R752	7030003640	S.RES ERJ3GEYJ 473 V (47 k)
R753	7030003360	S.RES ERJ3GEYJ 221 V (220)
R761	7030003440	S.RES ERJ3GEYJ 102 V (1 k)
R762	7030003660	S.RES ERJ3GEYJ 683 V (68 k)
R763	7030003680	S.RES ERJ3GEYJ 104 V (100 k)
R764	7030003580	S.RES ERJ3GEYJ 153 V (15 k)
R771	7030003520	S.RES ERJ3GEYJ 472 V (4.7 k)
R772	7030003440	S.RES ERJ3GEYJ 102 V (1 k)
R773	7030003540	S.RES ERJ3GEYJ 682 V (6.8 k)
R774	7030003440	S.RES ERJ3GEYJ 102 V (1 k)
R775	7030003800	S.RES ERJ3GEYJ 105 V (1 M)
R776	7030003320	S.RES ERJ3GEYJ 101 V (100)
R777	7030003320	S.RES ERJ3GEYJ 101 V (100)
R778	7030003560	S.RES ERJ3GEYJ 103 V (10 k)
R779	7030003520	S.RES ERJ3GEYJ 472 V (4.7 k)
R780	7030003640	S.RES ERJ3GEYJ 473 V (47 k)
R781	7030003680	S.RES ERJ3GEYJ 104 V (100 k)
R782	7030003420	S.RES ERJ3GEYJ 681 V (680)
R783	7030003640	S.RES ERJ3GEYJ 473 V (47 k)
R785	7030003640	S.RES ERJ3GEYJ 473 V (47 k)
R786	7030003200	S.RES ERJ3GEYJ 100 V (10)
R791	7030003480	S.RES ERJ3GEYJ 222 V (2.2 k)
R792	7030003560	S.RES ERJ3GEYJ 103 V (10 k)
R793	7030003460	S.RES ERJ3GEYJ 152 V (1.5 k)
R794	7030003740	S.RES ERJ3GEYJ 334 V (330 k)
R795	7030003700	S.RES ERJ3GEYJ 154 V (150 k)
R796	7030003500	S.RES ERJ3GEYJ 332 V (3.3 k)
R797	7030003440	S.RES ERJ3GEYJ 102 V (1 k)
R803	7030003520	S.RES ERJ3GEYJ 472 V (4.7 k)
R811	7030003560	S.RES ERJ3GEYJ 103 V (10 k)
R812	7030003630	S.RES ERJ3GEYJ 393 V (39 k)
R813	7030003560	S.RES ERJ3GEYJ 103 V (10 k)
R814	7030003700	S.RES ERJ3GEYJ 154 V (150 k)
R815	7030003700	S.RES ERJ3GEYJ 154 V (150 k)
R816	7030003320	S.RES ERJ3GEYJ 101 V (100)
R821	7030003840	S.RES ERJ3GEYJ 225 V (2.2 M)
R822	7030003800	S.RES ERJ3GEYJ 105 V (1 M)
R823	7030003670	S.RES ERJ3GEYJ 823 V (82 k)

[MAIN UNIT]

REF NO.	ORDER NO.	DESCRIPTION
R824	7030003670	S.RES ERJ3GEYJ 823 V (82 k)
R825	7030003670	S.RES ERJ3GEYJ 823 V (82 k)
R826	7030003680	S.RES ERJ3GEYJ 104 V (100 k)
R827	7030003690	S.RES ERJ3GEYJ 124 V (120 k)
R828	7030003760	S.RES ERJ3GEYJ 474 V (470 k)
R829	7030003680	S.RES ERJ3GEYJ 104 V (100 k)
R830	7030003840	S.RES ERJ3GEYJ 225 V (2.2 M)
R831	7030003800	S.RES ERJ3GEYJ 105 V (1 M)
R832	7030003560	S.RES ERJ3GEYJ 103 V (10 k)
R841	7030003400	S.RES ERJ3GEYJ 471 V (470)
R842	7030003320	S.RES ERJ3GEYJ 101 V (100)
R843	7030003440	S.RES ERJ3GEYJ 102 V (1 k)
R845	7030003650	S.RES ERJ3GEYJ 563 V (56 k)
R846	7030003680	S.RES ERJ3GEYJ 104 V (100 k)
R861	7030003600	S.RES ERJ3GEYJ 223 V (22 k)
R862	7030003660	S.RES ERJ3GEYJ 683 V (68 k)
R864	7030003580	S.RES ERJ3GEYJ 153 V (15 k)
R866	7030003760	S.RES ERJ3GEYJ 474 V (470 k)
R868	7030003580	S.RES ERJ3GEYJ 153 V (15 k)
R869	7030003570	S.RES ERJ3GEYJ 123 V (12 k)
R870	7030003640	S.RES ERJ3GEYJ 473 V (47 k)
R871	7030003560	S.RES ERJ3GEYJ 103 V (10 k)
R872	7030003560	S.RES ERJ3GEYJ 103 V (10 k)
R881	7030003560	S.RES ERJ3GEYJ 103 V (10 k)
R882	7030003560	S.RES ERJ3GEYJ 103 V (10 k)
R883	7030003640	S.RES ERJ3GEYJ 473 V (47 k)
R884	7030003560	S.RES ERJ3GEYJ 103 V (10 k)
R890	7030003700	S.RES ERJ3GEYJ 154 V (150 k)
R891	7030003690	S.RES ERJ3GEYJ 124 V (120 k)
R892	7030003650	S.RES ERJ3GEYJ 563 V (56 k)
R893	7030003640	S.RES ERJ3GEYJ 473 V (47 k)
R894	7030003680	S.RES ERJ3GEYJ 104 V (100 k)
R895	7030003520	S.RES ERJ3GEYJ 472 V (4.7 k)
R896	7310004250	TRI EVN-D2AA03 B25
R898	7030003680	S.RES ERJ3GEYJ 104 V (100 k)
R899	7030003680	S.RES ERJ3GEYJ 104 V (100 k)
R900	7310005020	S.TRI RH03ADC14X (10 k)
R901	7030003640	S.RES ERJ3GEYJ 473 V (47 k)
R902	7030003520	S.RES ERJ3GEYJ 472 V (4.7 k)
R903	7030003520	S.RES ERJ3GEYJ 472 V (4.7 k)
R911	7030005871	S.RES ERA3YKD 104V (100 k)
R912	7030005871	S.RES ERA3YKD 104V (100 k)
R913	7030003400	S.RES ERJ3GEYJ 471 V (470)
R921	7310005140	S.TRI RH03ADCJ3X (2.2 k)
R922	7030003550	S.RES ERJ3GEYJ 822 V (8.2 k)
R923	7030003400	S.RES ERJ3GEYJ 471 V (470)
R924	7030003520	S.RES ERJ3GEYJ 472 V (4.7 k)
R931	7030003520	S.RES ERJ3GEYJ 472 V (4.7 k)
R932	7030003670	S.RES ERJ3GEYJ 823 V (82 k)
R933	7030003680	S.RES ERJ3GEYJ 104 V (100 k)
R934	7030003560	S.RES ERJ3GEYJ 103 V (10 k)
R935	7030003540	S.RES ERJ3GEYJ 682 V (6.8 k)
R936	7030003600	S.RES ERJ3GEYJ 223 V (22 k)
R937	7030003560	S.RES ERJ3GEYJ 103 V (10 k)
R938	7030003680	S.RES ERJ3GEYJ 104 V (100 k)
R939	7030003720	S.RES ERJ3GEYJ 224 V (220 k)
R940	7030003540	S.RES ERJ3GEYJ 682 V (6.8 k)
R941	7030003360	S.RES ERJ3GEYJ 221 V (220)
R942	7030003440	S.RES ERJ3GEYJ 102 V (1 k)
R943	7030003540	S.RES ERJ3GEYJ 682 V (6.8 k)
R944	7030003600	S.RES ERJ3GEYJ 223 V (22 k)
R945	7310004250	TRI EVN-D2AA03 B25
R946	7030003560	S.RES ERJ3GEYJ 103 V (10 k)
R947	7030003290	S.RES ERJ3GEYJ 560 V (56)
R948	7030003640	S.RES ERJ3GEYJ 473 V (47 k)
R949	7030003640	S.RES ERJ3GEYJ 473 V (47 k)
R950	7030003720	S.RES ERJ3GEYJ 224 V (220 k)
R951	7030003720	S.RES ERJ3GEYJ 224 V (220 k)
R952	7030003520	S.RES ERJ3GEYJ 472 V (4.7 k)
R953	7030003560	S.RES ERJ3GEYJ 103 V (10 k)
R963	7030003320	S.RES ERJ3GEYJ 101 V (100)
R964	7030003620	S.RES ERJ3GEYJ 333 V (33 k)
R965	7030003360	S.RES ERJ3GEYJ 221 V (220)
R966	7030003510	S.RES ERJ3GEYJ 392 V (3.9 k)
R967	7030003440	S.RES ERJ3GEYJ 102 V (1 k)
R971	7030003560	S.RES ERJ3GEYJ 103 V (10 k)
R981	7030003200	S.RES ERJ3GEYJ 100 V (10)
R982	7030003640	S.RES ERJ3GEYJ 473 V (47 k)
R983	7030003590	S.RES ERJ3GEYJ 183 V (18 k)
R984	7030003580	S.RES ERJ3GEYJ 153 V (15 k)
R985	7030003700	S.RES ERJ3GEYJ 154 V (150 k)
R986	7030003710	S.RES ERJ3GEYJ 184 V (180 k)
R987	7030003370	S.RES ERJ3GEYJ 271 V (270)
R988	7030003700	S.RES ERJ3GEYJ 154 V (150 k)
R989	7030003700	S.RES ERJ3GEYJ 154 V (150 k)
R990	7030003730	S.RES ERJ3GEYJ 274 V (270 k)
R991	7030003780	S.RES ERJ3GEYJ 684 V (680 k)
R992	7030003750	S.RES ERJ3GEYJ 394 V (390 k)
R993	7030003670	S.RES ERJ3GEYJ 823 V (82 k)
R994	7030003670	S.RES ERJ3GEYJ 823 V (82 k)
R995	7030003450	S.RES ERJ3GEYJ 122 V (1.2 k)
R996	7030003440	S.RES ERJ3GEYJ 102 V (1 k)
R998	7030003600	S.RES ERJ3GEYJ 223 V (22 k)
R999	7310005020	S.TRI RH03ADC14X (10 k)
R1000	7030003410	S.RES ERJ3GEYJ 561 V (560)
R1001	7030003660	S.RES ERJ3GEYJ 683 V (68 k)
R1002	7310005050	S.TRI RH03ADCS3X (4.7 k)
R1003	7030003660	S.RES ERJ3GEYJ 683 V (68 k)
R1004	7030003560	S.RES ERJ3GEYJ 103 V (10 k)
R1010	7030003640	S.RES ERJ3GEYJ 473 V (47 k) except [EUR], [FRA], [ESP], [USA], [EUR-1], [ESP-1], [USA-1]
R1011	7030003320	S.RES ERJ3GEYJ 101 V (100)
R1012	7030003620	S.RES ERJ3GEYJ 333 V (33 k)
R1013	7030003580	S.RES ERJ3GEYJ 153 V (15 k)

S.=Surface mount

[MAIN UNIT]

REF NO.	ORDER NO.	DESCRIPTION
R1014	7030003830	S.RES ERJ3GEYJ 185 V (1.8 M)
R1015	7030003280	S.RES ERJ3GEYJ 470 V (47)
R1016	7030003640	S.RES ERJ3GEYJ 473 V (47 k)
R1017	7030003560	S.RES ERJ3GEYJ 103 V (10 k)
R1018	7030003680	S.RES ERJ3GEYJ 104 V (100 k)
R1019	7030003480	S.RES ERJ3GEYJ 222 V (2.2 k)
R1020	7030003760	S.RES ERJ3GEYJ 474 V (470 k)
R1021	7030003320	S.RES ERJ3GEYJ 101 V (100)
R1022	7030003680	S.RES ERJ3GEYJ 104 V (100 k)
R1023	7030003680	S.RES ERJ3GEYJ 104 V (100 k)
R1024	7030003340	S.RES ERJ3GEYJ 151 V (150)
R1025	7030003320	S.RES ERJ3GEYJ 101 V (100)
R1026	7030003680	S.RES ERJ3GEYJ 104 V (100 k)
R1027	7030003440	S.RES ERJ3GEYJ 102 V (1 k)
R1028	7030003440	S.RES ERJ3GEYJ 102 V (1 k)
R1029	7030003560	S.RES ERJ3GEYJ 103 V (10 k)
R1030	7030003560	S.RES ERJ3GEYJ 103 V (10 k)
R1041	7030003280	S.RES ERJ3GEYJ 470 V (47) except [USA], [USA-1], [EUR], [EUR-1]
R1042	7310005060	S.TRI RH03ADCE5X (150 k)
R1043	7030005680	S.RES RR0816R-473-D (47 k)
R1044	7030005680	S.RES RR0816R-473-D (47 k)
R1045	7310005050	S.TRI RH03ADCS3X (4.7 k)
R1046	7030003440	S.RES ERJ3GEYJ 102 V (1 k)
R1047	7030003440	S.RES ERJ3GEYJ 102 V (1 k)
R1048	7030003430	S.RES ERJ3GEYJ 821 V (820)
R1049	7030003450	S.RES ERJ3GEYJ 122 V (1.2 k)
R1050	7030003380	S.RES ERJ3GEYJ 331 V (330)
R1051	7030003550	S.RES ERJ3GEYJ 822 V (8.2 k)
R1052	7030003380	S.RES ERJ3GEYJ 331 V (330)
R1054	7030003420	S.RES ERJ3GEYJ 681 V (680)
R1055	7030003560	S.RES ERJ3GEYJ 103 V (10 k)
R1057	7030003440	S.RES ERJ3GEYJ 102 V (1 k)
R1061	7030003400	S.RES ERJ3GEYJ 471 V (470)
R1062	7030003440	S.RES ERJ3GEYJ 102 V (1 k)
R1070	7030003650	S.RES ERJ3GEYJ 563 V (56 k)
R1071	7030003640	S.RES ERJ3GEYJ 473 V (47 k)
R1072	7030003760	S.RES ERJ3GEYJ 474 V (470 k)
R1073	7030003800	S.RES ERJ3GEYJ 105 V (1 M)
R1074	7030003840	S.RES ERJ3GEYJ 225 V (2.2 M)
R1075	7030003560	S.RES ERJ3GEYJ 103 V (10 k)
R1076	7030003680	S.RES ERJ3GEYJ 104 V (100 k)
R1077	7030003720	S.RES ERJ3GEYJ 224 V (220 k)
R1079	7030003380	S.RES ERJ3GEYJ 331 V (330)
R1080	7310005150	S.TRI RH03ADCE5X (220 k)
R1081	7030003680	S.RES ERJ3GEYJ 104 V (100 k)
R1081	7030003740	S.RES ERJ3GEYJ 334 V (330 k)
R1082	7310005150	S.TRI RH03ADCE5X (220 k)
R1083	7030003700	S.RES ERJ3GEYJ 154 V (150 k)
R1083	7030003720	S.RES ERJ3GEYJ 224 V (220 k)
R1084	7310005150	S.TRI RH03ADCE5X (220 k)
R1085	7030003690	S.RES ERJ3GEYJ 124 V (120 k)
R1086	7310005150	S.TRI RH03ADCE5X (220 k)
R1087	7030003740	S.RES ERJ3GEYJ 334 V (330 k)
R1088	7310005150	S.TRI RH03ADCE5X (220 k)
R1091	7030003380	S.RES ERJ3GEYJ 331 V (330)
R1092	7030003400	S.RES ERJ3GEYJ 471 V (470)
R1093	7030003560	S.RES ERJ3GEYJ 103 V (10 k)
R1094	7030003340	S.RES ERJ3GEYJ 151 V (150)
R1095	7030004710	S.RES ERJ3GEYJ 475 V (4.7 M)
R1096	7030003600	S.RES ERJ3GEYJ 223 V (22 k)
R1097	7030003560	S.RES ERJ3GEYJ 103 V (10 k)
R1098	7030003560	S.RES ERJ3GEYJ 103 V (10 k)
R1099	7030003560	S.RES ERJ3GEYJ 103 V (10 k)
R1100	7030003360	S.RES ERJ3GEYJ 221 V (220)
R1101	7030003360	S.RES ERJ3GEYJ 221 V (220)
R1102	7030003440	S.RES ERJ3GEYJ 102 V (1 k)
R1103	7030003200	S.RES ERJ3GEYJ 100 V (10)
R1104	7030003320	S.RES ERJ3GEYJ 101 V (100)
R1111	7030003440	S.RES ERJ3GEYJ 102 V (1 k)
R1112	7030003800	S.RES ERJ3GEYJ 105 V (1 M)
R1113	7030003680	S.RES ERJ3GEYJ 104 V (100 k)
R1114	7030003560	S.RES ERJ3GEYJ 103 V (10 k)
R1115	7030003470	S.RES ERJ3GEYJ 182 V (1.8 k)
R1116	7030003400	S.RES ERJ3GEYJ 471 V (470)
R1121	7030003640	S.RES ERJ3GEYJ 473 V (47 k)
R1122	7030003640	S.RES ERJ3GEYJ 473 V (47 k)
R1123	7030003620	S.RES ERJ3GEYJ 333 V (33 k)
R1124	7030003620	S.RES ERJ3GEYJ 333 V (33 k)
R1125	7310005020	S.TRI RH03ADC14X (10 k)
R1126	7030003800	S.RES ERJ3GEYJ 105 V (1 M)
R1127	7030003400	S.RES ERJ3GEYJ 471 V (470)
R1128	7030010760	S.RES ERA3YKD 623V (62 k)
R1131	7030003560	S.RES ERJ3GEYJ 103 V (10 k)
R1132	7030003440	S.RES ERJ3GEYJ 102 V (1 k)
R1133	7030003680	S.RES ERJ3GEYJ 104 V (100 k)
R1141	7030003640	S.RES ERJ3GEYJ 473 V (47 k)
R1142	7030003640	S.RES ERJ3GEYJ 473 V (47 k)
R1143	7030003760	S.RES ERJ3GEYJ 474 V (470 k)
R1144	7030003760	S.RES ERJ3GEYJ 474 V (470 k)
R1145	7030003520	S.RES ERJ3GEYJ 472 V (4.7 k)
R1146	7030003760	S.RES ERJ3GEYJ 474 V (470 k)
R1147	7030003760	S.RES ERJ3GEYJ 474 V (470 k)
R1148	7030003760	S.RES ERJ3GEYJ 474 V (470 k)
R1149	7030003560	S.RES ERJ3GEYJ 103 V (10 k) except [USA], [USA-1], [EUR], [EUR-1]
R1150	7030003440	S.RES ERJ3GEYJ 102 V (1 k) except [USA], [USA-1], [EUR], [EUR-1]
R1161	7030003680	S.RES ERJ3GEYJ 104 V (100 k)
R1162	7030003680	S.RES ERJ3GEYJ 104 V (100 k)
R1163	7030003580	S.RES ERJ3GEYJ 153 V (15 k)
R1164	7030003590	S.RES ERJ3GEYJ 183 V (18 k)
R1165	7030003680	S.RES ERJ3GEYJ 104 V (100 k)
R1166	7030003740	S.RES ERJ3GEYJ 334 V (330 k)

[MAIN UNIT]

REF NO.	ORDER NO.	DESCRIPTION
R1167	7030003680	S.RES ERJ3GEYJ 104 V (100 k)
R1168	7030003680	S.RES ERJ3GEYJ 104 V (100 k)
R1169	7030003700	S.RES ERJ3GEYJ 154 V (150 k)
R1170	7030003680	S.RES ERJ3GEYJ 104 V (100 k)
R2001	7030003360	S.RES ERJ3GEYJ 221 V (220)
R2002	7030003440	S.RES ERJ3GEYJ 102 V (1 k)
R2003	7030003440	S.RES ERJ3GEYJ 102 V (1 k)
R2004	7030003640	S.RES ERJ3GEYJ 473 V (47 k)
R2005	7030003640	S.RES ERJ3GEYJ 473 V (47 k)
R2011	7030003320	S.RES ERJ3GEYJ 101 V (100)
R2012	7030003440	S.RES ERJ3GEYJ 102 V (1 k)
R2013	7030003440	S.RES ERJ3GEYJ 102 V (1 k)
R2014	7030003440	S.RES ERJ3GEYJ 102 V (1 k)
R2015	7030003440	S.RES ERJ3GEYJ 102 V (1 k)
R2016	7030003440	S.RES ERJ3GEYJ 102 V (1 k)
R2017	7030003440	S.RES ERJ3GEYJ 102 V (1 k)
R2018	7030003440	S.RES ERJ3GEYJ 102 V (1 k)
R2019	7030003440	S.RES ERJ3GEYJ 102 V (1 k)
R2021	7030003640	S.RES ERJ3GEYJ 473 V (47 k)
R2041	7030003440	S.RES ERJ3GEYJ 102 V (1 k)
R2042	7030003440	S.RES ERJ3GEYJ 102 V (1 k)
R2044	7030003440	S.RES ERJ3GEYJ 102 V (1 k)
R2045	7030003640	S.RES ERJ3GEYJ 473 V (47 k)
R2051	7030003440	S.RES ERJ3GEYJ 102 V (1 k)
R2052	7030003440	S.RES ERJ3GEYJ 102 V (1 k)
R2053	7030003440	S.RES ERJ3GEYJ 102 V (1 k)
R2054	7030003440	S.RES ERJ3GEYJ 102 V (1 k)
R2055	7030003440	S.RES ERJ3GEYJ 102 V (1 k)
R2056	7030003440	S.RES ERJ3GEYJ 102 V (1 k)
R2057	7030003440	S.RES ERJ3GEYJ 102 V (1 k)
R2058	7030003440	S.RES ERJ3GEYJ 102 V (1 k)
R2061	7030003320	S.RES ERJ3GEYJ 101 V (100)
R2062	7030003320	S.RES ERJ3GEYJ 101 V (100)
R2063	7030003320	S.RES ERJ3GEYJ 101 V (100)
R2064	7030003320	S.RES ERJ3GEYJ 101 V (100)
R2065	7030003320	S.RES ERJ3GEYJ 101 V (100)
R2072	7030003440	S.RES ERJ3GEYJ 102 V (1 k)
R2074	7030003440	S.RES ERJ3GEYJ 102 V (1 k)
R2076	7030003800	S.RES ERJ3GEYJ 105 V (1 M)
R2077	7030003640	S.RES ERJ3GEYJ 473 V (47 k)
R2081	7030003520	S.RES ERJ3GEYJ 472 V (4.7 k)
R2084	7030003520	S.RES ERJ3GEYJ 472 V (4.7 k)
R2085	7030003520	S.RES ERJ3GEYJ 472 V (4.7 k)
R2086	7030003440	S.RES ERJ3GEYJ 102 V (1 k)
R2087	7030006560	S.RES RR0816P-223-D (22 k)
R2088	7030006560	S.RES RR0816P-223-D (22 k)
R2089	7030006560	S.RES RR0816P-223-D (22 k)
R2090	7030006560	S.RES RR0816P-223-D (22 k)
R2101	7030003520	S.RES ERJ3GEYJ 472 V (4.7 k)
R2102	7030003520	S.RES ERJ3GEYJ 472 V (4.7 k)
R2103	7030003520	S.RES ERJ3GEYJ 472 V (4.7 k)
R2104	7030003520	S.RES ERJ3GEYJ 472 V (4.7 k)
R2105	7030003520	S.RES ERJ3GEYJ 472 V (4.7 k)
R2106	7030003480	S.RES ERJ3GEYJ 222 V (2.2 k)
R2107	7030003520	S.RES ERJ3GEYJ 472 V (4.7 k)
R2108	7030003440	S.RES ERJ3GEYJ 102 V (1 k)
R2109	7030003520	S.RES ERJ3GEYJ 472 V (4.7 k)
R2110	7030003520	S.RES ERJ3GEYJ 472 V (4.7 k)
R2111	7030003680	S.RES ERJ3GEYJ 104 V (100 k)
R2112	7030003680	S.RES ERJ3GEYJ 104 V (100 k)
R2113	7030003750	S.RES ERJ3GEYJ 394 V (390 k)
R2121	7030003640	S.RES ERJ3GEYJ 473 V (47 k)
R2122	7030003640	S.RES ERJ3GEYJ 473 V (47 k)
R2123	7030003680	S.RES ERJ3GEYJ 104 V (100 k)
R2124	7030003680	S.RES ERJ3GEYJ 104 V (100 k)
R2131	7030003800	S.RES ERJ3GEYJ 105 V (1 M)
R2132	7030003640	S.RES ERJ3GEYJ 473 V (47 k)
R2133	7030003440	S.RES ERJ3GEYJ 102 V (1 k)
R2134	7030003440	S.RES ERJ3GEYJ 102 V (1 k)
R2141	7030003560	S.RES ERJ3GEYJ 103 V (10 k)
R2142	7030003440	S.RES ERJ3GEYJ 102 V (1 k)
R2143	7030003640	S.RES ERJ3GEYJ 473 V (47 k)
R2144	7030003440	S.RES ERJ3GEYJ 102 V (1 k)
R2146	7030003640	S.RES ERJ3GEYJ 473 V (47 k)
R2147	7030003440	S.RES ERJ3GEYJ 102 V (1 k)
R2148	7030003640	S.RES ERJ3GEYJ 473 V (47 k)
R2149	7030003440	S.RES ERJ3GEYJ 102 V (1 k)
R2150	7030003400	S.RES ERJ3GEYJ 471 V (470)
R2151	7030003640	S.RES ERJ3GEYJ 473 V (47 k)
R2152	7030003640	S.RES ERJ3GEYJ 473 V (47 k)
R2161	7030003560	S.RES ERJ3GEYJ 103 V (10 k)
R2162	7030003520	S.RES ERJ3GEYJ 472 V (4.7 k)
R2163	7030003630	S.RES ERJ3GEYJ 393 V (39 k)
R2164	7030003620	S.RES ERJ3GEYJ 333 V (33 k)
R2165	7030003320	S.RES ERJ3GEYJ 101 V (100)
R2166	7030003320	S.RES ERJ3GEYJ 101 V (100)
R2167	7030003560	S.RES ERJ3GEYJ 103 V (10 k)
R2171	7030003680	S.RES ERJ3GEYJ 104 V (100 k)
R2172	7030003540	S.RES ERJ3GEYJ 682 V (6.8 k)
R2173	7030003620	S.RES ERJ3GEYJ 333 V (33 k)
R2174	7030003640	S.RES ERJ3GEYJ 473 V (47 k)
R2175	7030003590	S.RES ERJ3GEYJ 183 V (18 k)
R2201	7030009851	S.RES ERA3YED 271V (270)
R2202	7030009861	S.RES ERA3YED 471V (470)
R2203	7030003680	S.RES ERJ3GEYJ 104 V (100 k)
R2204	7030003680	S.RES ERJ3GEYJ 104 V (100 k)
R2205	7030003680	S.RES ERJ3GEYJ 104 V (100 k)
R2206	7030003680	S.RES ERJ3GEYJ 104 V (100 k)
R2207	7030003680	S.RES ERJ3GEYJ 104 V (100 k)
R2208	7030003680	S.RES ERJ3GEYJ 104 V (100 k)
R2209	7030003680	S.RES ERJ3GEYJ 104 V (100 k)
R2210	7030003680	S.RES ERJ3GEYJ 104 V (100 k)
R2211	7030003560	S.RES ERJ3GEYJ 103 V (10 k)
R2212	7030003560	S.RES ERJ3GEYJ 103 V (10 k)

S.=Surface mount



[MAIN UNIT]

REF NO.	ORDER NO.	DESCRIPTION
R2213	7030003560	S.RES ERJ3GEYJ 103 V (10 k)
R2214	7030003560	S.RES ERJ3GEYJ 103 V (10 k)
R2215	7030003480	S.RES ERJ3GEYJ 222 V (2.2 k)
R2221	7030003320	S.RES ERJ3GEYJ 101 V (100)
R2231	7030003320	S.RES ERJ3GEYJ 101 V (100)
R2241	7030003420	S.RES ERJ3GEYJ 681 V (680)
R2242	7030003420	S.RES ERJ3GEYJ 681 V (680)
R2243	7030003420	S.RES ERJ3GEYJ 681 V (680)
R2244	7030003410	S.RES ERJ3GEYJ 561 V (560)
R2245	7030003360	S.RES ERJ3GEYJ 221 V (220)
C111	4030011600	S.CER C1608 JB 1E 104K-T
C112	4030011600	S.CER C1608 JB 1E 104K-T
C113	4030011600	S.CER C1608 JB 1E 104K-T
C114	4030008650	S.CER C1608 JB 1H 332K-T
C115	4030011330	S.CER C1608 CH 1H 391J-T
C116	4030008650	S.CER C1608 JB 1H 332K-T
C121	4030011600	S.CER C1608 JB 1E 104K-T
C122	4030008470	S.CER C1608 JB 1H 272K-T
C123	4030009880	S.CER C1608 JB 1H 682K-T
C124	4030009980	S.CER C1608 JB 1H 152K-T
C125	4030011600	S.CER C1608 JB 1E 104K-T
C131	4030011600	S.CER C1608 JB 1E 104K-T
C132	4030011600	S.CER C1608 JB 1E 104K-T
C133	4030007060	S.CER C1608 CH 1H 270J-T
C134	4030007080	S.CER C1608 CH 1H 390J-T
C135	4030011540	S.CER C1608 CH 1H 750J-T
C136	4030007020	S.CER C1608 CH 1H 120J-T
C137	4030007090	S.CER C1608 CH 1H 470J-T
C138	4030011600	S.CER C1608 JB 1E 104K-T
C141	4030011600	S.CER C1608 JB 1E 104K-T
C142	4030006870	S.CER C1608 JB 1H 222K-T
C143	4030006870	S.CER C1608 JB 1H 222K-T
C144	4030008870	S.CER C1608 JB 1H 183K-T
C153	4030011600	S.CER C1608 JB 1E 104K-T
C155	4030011600	S.CER C1608 JB 1E 104K-T
C157	4030011600	S.CER C1608 JB 1E 104K-T
C158	4030011600	S.CER C1608 JB 1E 104K-T
C159	4030011600	S.CER C1608 JB 1E 104K-T
C161	4030011600	S.CER C1608 JB 1E 104K-T
C163	4030011600	S.CER C1608 JB 1E 104K-T
C165	4030011600	S.CER C1608 JB 1E 104K-T
C167	4030011600	S.CER C1608 JB 1E 104K-T
C168	4030007010	S.CER C1608 CH 1H 100D-T
C169	4030006860	S.CER C1608 JB 1H 102K-T
C171	4030011600	S.CER C1608 JB 1E 104K-T
C173	4030011600	S.CER C1608 JB 1E 104K-T
C181	4030009920	S.CER C1608 CH 1H 050B-T
C182	4030009500	S.CER C1608 CH 1H 0R5B-T
C183	4030009910	S.CER C1608 CH 1H 040B-T
C184	4030009500	S.CER C1608 CH 1H 0R5B-T
C185	4030009920	S.CER C1608 CH 1H 050B-T
C186	4030007060	S.CER C1608 CH 1H 270J-T
C187	4030006860	S.CER C1608 JB 1H 102K-T
C188	4030006860	S.CER C1608 JB 1H 102K-T
C191	4030006880	S.CER C1608 JB 1H 472K-T
C192	4030006880	S.CER C1608 JB 1H 472K-T
C195	4030006990	S.CER C1608 CH 1H 080D-T
C196	4030007050	S.CER C1608 CH 1H 220J-T
C197	4030008560	S.CER C1608 CH 1H 300J-T
C201	4030006860	S.CER C1608 JB 1H 102K-T
C212	4030006860	S.CER C1608 JB 1H 102K-T
C222	4030011600	S.CER C1608 JB 1E 104K-T
C223	4030006860	S.CER C1608 JB 1H 102K-T
C224	4030006860	S.CER C1608 JB 1H 102K-T
C226	4030011600	S.CER C1608 JB 1E 104K-T
C233	4030011600	S.CER C1608 JB 1E 104K-T
C235	4030011600	S.CER C1608 JB 1E 104K-T
C236	4030007030	S.CER C1608 CH 1H 150J-T
C237	4030011600	S.CER C1608 JB 1E 104K-T
C238	4030011600	S.CER C1608 JB 1E 104K-T
C239	4510009060	S.ELE EEE1HA3R35R
C251	4030006880	S.CER C1608 JB 1H 472K-T
C253	4030011770	S.CER C1608 CH 1H 060B-T
C254	4030009540	S.CER C1608 CH 1H 1R5B-T
C255	4030007010	S.CER C1608 CH 1H 100D-T
C256	4030009540	S.CER C1608 CH 1H 1R5B-T
C257	4030007010	S.CER C1608 CH 1H 100D-T
C258	4030009910	S.CER C1608 CH 1H 040B-T
C259	4030009910	S.CER C1608 CH 1H 040B-T
C261	4030007050	S.CER C1608 CH 1H 220J-T
C262	4030007040	S.CER C1608 CH 1H 180J-T
C263	4030007070	S.CER C1608 CH 1H 330J-T
C264	4030006990	S.CER C1608 CH 1H 080D-T
C270	4030006860	S.CER C1608 JB 1H 102K-T
C271	4030006860	S.CER C1608 JB 1H 102K-T except [USA], [USA-1], [EUR], [EUR-1] except [USA], [USA-1], [EUR], [EUR-1]
C272	4030007010	S.CER C1608 CH 1H 100D-T
C273	4030006880	S.CER C1608 JB 1H 472K-T
C275	4030006860	S.CER C1608 JB 1H 102K-T
C276	4030006860	S.CER C1608 JB 1H 102K-T
C277	4030006860	S.CER C1608 JB 1H 102K-T
C278	4030006860	S.CER C1608 JB 1H 102K-T
C279	4030006860	S.CER C1608 JB 1H 102K-T
C280	4030007020	S.CER C1608 CH 1H 120J-T except [EUR], [FRA], [ESP], [USA], [EUR-1], [ESP-1], [USA-1]
C281	4030006880	S.CER C1608 JB 1H 472K-T
C282	4030006880	S.CER C1608 JB 1H 472K-T
C283	4030006880	S.CER C1608 JB 1H 472K-T
C284	4030006860	S.CER C1608 JB 1H 102K-T
C285	4030007090	S.CER C1608 CH 1H 470J-T

[MAIN UNIT]

REF NO.	ORDER NO.	DESCRIPTION
C286	4030006860	S.CER C1608 JB 1H 102K-T
C287	4030006860	S.CER C1608 JB 1H 102K-T
C289	4030006860	S.CER C1608 JB 1H 102K-T
C290	4030011600	S.CER C1608 JB 1E 104K-T
C300	4030006860	S.CER C1608 JB 1H 102K-T
C301	4030006860	S.CER C1608 JB 1H 102K-T
C302	4030006860	S.CER C1608 JB 1H 102K-T
C303	4030006860	S.CER C1608 JB 1H 102K-T
C351	4510008540	S.ELE EEE1CA100SR
C352	4030011600	S.CER C1608 JB 1E 104K-T
C353	4030006860	S.CER C1608 JB 1H 102K-T
C354	4030006860	S.CER C1608 JB 1H 102K-T
C361	4030011600	S.CER C1608 JB 1E 104K-T
C362	4030011600	S.CER C1608 JB 1E 104K-T
C363	4030011600	S.CER C1608 JB 1E 104K-T
C364	4030011600	S.CER C1608 JB 1E 104K-T
C365	4030011600	S.CER C1608 JB 1E 104K-T
C366	4030011600	S.CER C1608 JB 1E 104K-T
C367	4030011600	S.CER C1608 JB 1E 104K-T
C371	4030006850	S.CER C1608 JB 1H 471K-T
C372	4030006990	S.CER C1608 CH 1H 080D-T
C373	4030006990	S.CER C1608 CH 1H 080D-T
C374	4030006990	S.CER C1608 CH 1H 080D-T
C375	4030006990	S.CER C1608 CH 1H 080D-T
C376	4030006850	S.CER C1608 JB 1H 471K-T
C401	4030006880	S.CER C1608 JB 1H 472K-T
C402	4030006880	S.CER C1608 JB 1H 472K-T
C403	4030006880	S.CER C1608 JB 1H 472K-T
C404	4030006880	S.CER C1608 JB 1H 472K-T
C405	4030006880	S.CER C1608 JB 1H 472K-T
C406	4030006880	S.CER C1608 JB 1H 472K-T
C407	4030006880	S.CER C1608 JB 1H 472K-T
C408	4030006880	S.CER C1608 JB 1H 472K-T
C409	4030006880	S.CER C1608 JB 1H 472K-T
C410	4030006880	S.CER C1608 JB 1H 472K-T
C411	4030006880	S.CER C1608 JB 1H 472K-T
C412	4030006880	S.CER C1608 JB 1H 472K-T
C413	4030006880	S.CER C1608 JB 1H 472K-T
C414	4030006850	S.CER C1608 JB 1H 471K-T
C415	4030006850	S.CER C1608 JB 1H 471K-T
C417	4030006880	S.CER C1608 JB 1H 472K-T
C418	4030006860	S.CER C1608 JB 1H 102K-T
C426	4030011600	S.CER C1608 JB 1E 104K-T
C432	4030006880	S.CER C1608 JB 1H 472K-T
C434	4030006880	S.CER C1608 JB 1H 472K-T
C439	4030006850	S.CER C1608 JB 1H 471K-T
C440	4030006850	S.CER C1608 JB 1H 471K-T
C445	4030006880	S.CER C1608 JB 1H 472K-T
C461	4030006880	S.CER C1608 JB 1H 472K-T
C462	4030006880	S.CER C1608 JB 1H 472K-T
C463	4030006850	S.CER C1608 JB 1H 471K-T
C465	4030006880	S.CER C1608 JB 1H 472K-T
C466	4030006880	S.CER C1608 JB 1H 472K-T
C467	4030006880	S.CER C1608 JB 1H 472K-T
C468	4030006880	S.CER C1608 JB 1H 472K-T
C469	4030006880	S.CER C1608 JB 1H 472K-T
C470	4030006880	S.CER C1608 JB 1H 472K-T
C471	4030006880	S.CER C1608 JB 1H 472K-T
C472	4030006880	S.CER C1608 JB 1H 472K-T
C473	4030006880	S.CER C1608 JB 1H 472K-T
C474	4030006860	S.CER C1608 JB 1H 102K-T
C475	4030006880	S.CER C1608 JB 1H 472K-T
C476	4030006880	S.CER C1608 JB 1H 472K-T
C501	4030007000	S.CER C1608 CH 1H 090D-T
C502	4030007170	S.CER C1608 CH 1H 221J-T
C503	4030007000	S.CER C1608 CH 1H 090D-T
C504	4030007040	S.CER C1608 CH 1H 180J-T
C505	4030007170	S.CER C1608 CH 1H 221J-T
C506	4030006880	S.CER C1608 JB 1H 472K-T
C507	4030006880	S.CER C1608 JB 1H 472K-T
C511	4030006880	S.CER C1608 JB 1H 472K-T
C512	4030006990	S.CER C1608 CH 1H 080D-T
C513	4030006990	S.CER C1608 CH 1H 080D-T
C514	4030006880	S.CER C1608 JB 1H 472K-T
C515	4030006860	S.CER C1608 JB 1H 102K-T
C516	4030006860	S.CER C1608 JB 1H 102K-T
C521	4030006880	S.CER C1608 JB 1H 472K-T
C522	4030006880	S.CER C1608 JB 1H 472K-T
C523	4030011600	S.CER C1608 JB 1E 104K-T
C524	4030006860	S.CER C1608 JB 1H 102K-T
C525	4030006880	S.CER C1608 JB 1H 472K-T
C526	4030006880	S.CER C1608 JB 1H 472K-T
C527	4030006880	S.CER C1608 JB 1H 472K-T
C528	4030006880	S.CER C1608 JB 1H 472K-T
C529	4030006880	S.CER C1608 JB 1H 472K-T
C530	4030006860	S.CER C1608 JB 1H 102K-T
C531	4030011600	S.CER C1608 JB 1E 104K-T
C532	4030009650	S.CER C1608 CH 1H 240J-T
C533	4030009650	S.CER C1608 CH 1H 240J-T
C534	4030011600	S.CER C1608 JB 1E 104K-T
C536	4030011600	S.CER C1608 JB 1E 104K-T
C537	4030006860	S.CER C1608 JB 1H 102K-T
C541	4030007170	S.CER C1608 CH 1H 221J-T
C542	4030007020	S.CER C1608 CH 1H 120J-T
C543	4030007070	S.CER C1608 CH 1H 330J-T
C544	4030007170	S.CER C1608 CH 1H 221J-T
C545	4030007050	S.CER C1608 CH 1H 220J-T
C546	4550006770	S.TAN TEESVD2 1C 476M-12R
C552	4030007110	S.CER C1608 CH 1H 680J-T
C553	4030011600	S.CER C1608 JB 1E 104K-T
C561	4030011600	S.CER C1608 JB 1E 104K-T
C562	4030007020	S.CER C1608 CH 1H 120J-T
C563	4030007040	S.CER C1608 CH 1H 180J-T
C564	4030009520	S.CER C1608 CH 1H 020B-T

S.=Surface mount

[MAIN UNIT]

REF NO.	ORDER NO.	DESCRIPTION
C565	4030011600	S.CER C1608 JB 1E 104K-T
C566	4030011600	S.CER C1608 JB 1E 104K-T
C567	4030011280	S.CER C1608 CH 1H 271J-T
C571	4030006880	S.CER C1608 JB 1H 472K-T
C572	4030006880	S.CER C1608 JB 1H 472K-T
C573	4030011600	S.CER C1608 JB 1E 104K-T
C574	4030011600	S.CER C1608 JB 1E 104K-T
C575	4030006880	S.CER C1608 JB 1H 472K-T
C576	4030006880	S.CER C1608 JB 1H 472K-T
C577	4030006880	S.CER C1608 JB 1H 472K-T
C578	4030006880	S.CER C1608 JB 1H 472K-T
C579	4030006880	S.CER C1608 JB 1H 472K-T
C580	4030007100	S.CER C1608 CH 1H 560J-T
C581	4030007100	S.CER C1608 CH 1H 560J-T
C582	4030011600	S.CER C1608 JB 1E 104K-T
C583	4030011600	S.CER C1608 JB 1E 104K-T
C585	4030011600	S.CER C1608 JB 1E 104K-T
C587	4030011600	S.CER C1608 JB 1E 104K-T
C588	4030011600	S.CER C1608 JB 1E 104K-T
C589	4030011600	S.CER C1608 JB 1E 104K-T
C590	4030011600	S.CER C1608 JB 1E 104K-T
C591	4030011600	S.CER C1608 JB 1E 104K-T
C601	4030007150	S.CER C1608 CH 1H 151J-T
C602	4030007060	S.CER C1608 CH 1H 270J-T
C603	4030007150	S.CER C1608 CH 1H 151J-T
C604	4030006880	S.CER C1608 JB 1H 472K-T
C605	4030006880	S.CER C1608 JB 1H 472K-T
C606	4030006880	S.CER C1608 JB 1H 472K-T
C607	4030006880	S.CER C1608 JB 1H 472K-T
C611	4030006880	S.CER C1608 JB 1H 472K-T
C612	4030006880	S.CER C1608 JB 1H 472K-T
C613	4030006880	S.CER C1608 JB 1H 472K-T
C621	4030011600	S.CER C1608 JB 1E 104K-T
C622	4030007120	S.CER C1608 CH 1H 820J-T
C623	4030011600	S.CER C1608 JB 1E 104K-T
C624	4030011600	S.CER C1608 JB 1E 104K-T
C625	4030011600	S.CER C1608 JB 1E 104K-T
C631	4030006880	S.CER C1608 JB 1H 472K-T
C632	4030011600	S.CER C1608 JB 1E 104K-T
C633	4030011600	S.CER C1608 JB 1E 104K-T
C634	4030007040	S.CER C1608 CH 1H 180J-T
C635	4030007010	S.CER C1608 CH 1H 100D-T
C636	4030006860	S.CER C1608 JB 1H 102K-T
C637	4030011600	S.CER C1608 JB 1E 104K-T
C638	4030006880	S.CER C1608 JB 1H 472K-T
C639	4030011600	S.CER C1608 JB 1E 104K-T
C640	4030007120	S.CER C1608 CH 1H 820J-T
C641	4030011600	S.CER C1608 JB 1E 104K-T
C642	4030007150	S.CER C1608 CH 1H 151J-T
C643	4550007350	S.TAN F931C226MCMBMA
C644	4030007050	S.CER C1608 CH 1H 220J-T
C645	4550006770	S.TAN TEESVD2 1C 476M-12R
C646	4030011600	S.CER C1608 JB 1E 104K-T
C647	4550006080	S.TAN TEESVB2 1C 106M8R
C648	4030006880	S.CER C1608 JB 1H 472K-T
C649	4030011600	S.CER C1608 JB 1E 104K-T
C661	4030006880	S.CER C1608 JB 1H 472K-T
C662	4030006880	S.CER C1608 JB 1H 472K-T
C663	4030011600	S.CER C1608 JB 1E 104K-T
C664	4030011600	S.CER C1608 JB 1E 104K-T
C671	4030006880	S.CER C1608 JB 1H 472K-T
C672	4030011600	S.CER C1608 JB 1E 104K-T
C673	4030011600	S.CER C1608 JB 1E 104K-T
C681	4030007030	S.CER C1608 CH 1H 150J-T
C682	4030009540	S.CER C1608 CH 1H 1R5B-T
C683	4030007120	S.CER C1608 CH 1H 820J-T
C684	4030011600	S.CER C1608 JB 1E 104K-T
C685	4030011600	S.CER C1608 JB 1E 104K-T
C691	4030006880	S.CER C1608 JB 1H 472K-T
C692	4030011600	S.CER C1608 JB 1E 104K-T
C701	4030006880	S.CER C1608 JB 1H 472K-T
C702	4030011600	S.CER C1608 JB 1E 104K-T
C703	4030011600	S.CER C1608 JB 1E 104K-T
C711	4030006880	S.CER C1608 JB 1H 472K-T
C712	4030011600	S.CER C1608 JB 1E 104K-T
C713	4030011600	S.CER C1608 JB 1E 104K-T
C721	4030007050	S.CER C1608 CH 1H 220J-T
C722	4030011600	S.CER C1608 JB 1E 104K-T
C731	4030006880	S.CER C1608 JB 1H 472K-T
C732	4030006880	S.CER C1608 JB 1H 472K-T
C733	4030011600	S.CER C1608 JB 1E 104K-T
C734	4030007090	S.CER C1608 CH 1H 470J-T
C735	4030011600	S.CER C1608 JB 1E 104K-T
C736	4030011600	S.CER C1608 JB 1E 104K-T
C741	4030006880	S.CER C1608 JB 1H 472K-T
C742	4030007090	S.CER C1608 CH 1H 470J-T
C743	4030011600	S.CER C1608 JB 1E 104K-T
C751	4030007170	S.CER C1608 CH 1H 221J-T
C752	4030011600	S.CER C1608 JB 1E 104K-T
C761	4030006880	S.CER C1608 JB 1H 472K-T
C762	4030006870	S.CER C1608 JB 1H 222K-T
C763	4030006880	S.CER C1608 JB 1H 472K-T
C764	4030006900	S.CER C1608 JB 1H 103K-T
C771	4030007150	S.CER C1608 CH 1H 151J-T
C772	4030007130	S.CER C1608 CH 1H 101J-T
C773	4030006880	S.CER C1608 JB 1H 472K-T
C774	4030012610	S.CER C2012 JB 1C 474K-T
C775	4510008540	S.ELE EEE1CA100SR
C776	4030011600	S.CER C1608 JB 1E 104K-T
C777	4030006880	S.CER C1608 JB 1H 472K-T
C778	4030006880	S.CER C1608 JB 1H 472K-T
C779	4550007220	S.TAN F931A476MCMBMA
C791	4030006880	S.CER C1608 JB 1H 472K-T
C792	4030006880	S.CER C1608 JB 1H 472K-T

[MAIN UNIT]

REF NO.	ORDER NO.	DESCRIPTION
C793	4030006880	S.CER C1608 JB 1H 472K-T
C794	4510009270	S.ELE EEEHBI C220UR
C795	4030007130	S.CER C1608 CH 1H 101J-T
C796	4030011600	S.CER C1608 JB 1E 104K-T
C797	4030006880	S.CER C1608 JB 1H 472K-T
C798	4030006900	S.CER C1608 JB 1H 103K-T
C799	4030007170	S.CER C1608 CH 1H 221J-T
C800	4030007170	S.CER C1608 CH 1H 221J-T
C801	4030011600	S.CER C1608 JB 1E 104K-T
C802	4030011600	S.CER C1608 JB 1E 104K-T
C803	4030010210	S.CER C3216 JB 1C 105M-T
C811	4030011600	S.CER C1608 JB 1E 104K-T
C812	4030006900	S.CER C1608 JB 1H 103K-T
C813	4030006900	S.CER C1608 JB 1H 103K-T
C814	4030011600	S.CER C1608 JB 1E 104K-T
C815	4510008540	S.ELE EEE1CA100SR
C821	4030011600	S.CER C1608 JB 1E 104K-T
C822	4030008910	S.CER C1608 JB 1H 393K-T
C823	4030011600	S.CER C1608 JB 1E 104K-T
C824	4030009980	S.CER C1608 JB 1H 152K-T
C825	4030011600	S.CER C1608 JB 1E 104K-T
C826	4030011600	S.CER C1608 JB 1E 104K-T
C827	4030006880	S.CER C1608 JB 1H 472K-T
C828	4030007130	S.CER C1608 CH 1H 101J-T
C841	4030006880	S.CER C1608 JB 1H 472K-T
C842	4030006880	S.CER C1608 JB 1H 472K-T
C843	4030011600	S.CER C1608 JB 1E 104K-T
C844	4030011600	S.CER C1608 JB 1E 104K-T
C845	4030011600	S.CER C1608 JB 1E 104K-T
C846	4030006880	S.CER C1608 JB 1H 472K-T
C847	4030006880	S.CER C1608 JB 1H 472K-T
C848	4510008540	S.ELE EEE1CA100SR
C849	4030008920	S.CER C1608 JB 1H 473K-T
C850	4030011600	S.CER C1608 JB 1E 104K-T
C851	4030007130	S.CER C1608 CH 1H 101J-T
C861	4510008540	S.ELE EEE1CA100SR
C862	4030006880	S.CER C1608 JB 1H 472K-T
C881	4030006880	S.CER C1608 JB 1H 472K-T
C882	4030006870	S.CER C1608 JB 1H 222K-T
C883	4030008680	S.CER C2012 JB 1C 105Z-T
C891	4030011600	S.CER C1608 JB 1E 104K-T
C892	4030006900	S.CER C1608 JB 1H 103K-T
C893	4030006860	S.CER C1608 JB 1H 102K-T
C894	4030006880	S.CER C1608 JB 1H 472K-T
C895	4030010210	S.CER C3216 JB 1C 105M-T
C896	4030011600	S.CER C1608 JB 1E 104K-T
C897	4030008680	S.CER C2012 JB 1C 105Z-T
C898	4030011600	S.CER C1608 JB 1E 104K-T
C899	4030006860	S.CER C1608 JB 1H 102K-T
C921	4030010210	S.CER C3216 JB 1C 105M-T
C922	4550006390	S.TAN TEESVA 1C 335M8R
C924	4510005540	ELE 10 ME 33 SWB
C931	4030010210	S.CER C3216 JB 1C 105M-T
C932	4030006850	S.CER C1608 JB 1H 471K-T
C933	4510008530	S.ELE EEE1HA2R2SR
C934	4030006850	S.CER C1608 JB 1H 471K-T
C935	4030008920	S.CER C1608 JB 1H 473K-T
C936	4030011600	S.CER C1608 JB 1E 104K-T
C937	4030011600	S.CER C1608 JB 1E 104K-T
C938	4030007130	S.CER C1608 CH 1H 101J-T
C939	4030010210	S.CER C3216 JB 1C 105M-T
C940	4510008540	S.ELE EEE1CA100SR
C941	4510009270	S.ELE EEEHBI C220UR
C942	4030011600	S.CER C1608 JB 1E 104K-T
C943	4030008910	S.CER C1608 JB 1H 393K-T
C944	4030011600	S.CER C1608 JB 1E 104K-T
C945	4030010210	S.CER C3216 JB 1C 105M-T
C946	4030011600	S.CER C1608 JB 1E 104K-T
C961	4030012610	S.CER C2012 JB 1C 474K-T
C963	4510008540	S.ELE EEE1CA100SR
C964	4030010210	S.CER C3216 JB 1C 105M-T
C971	4030006880	S.CER C1608 JB 1H 472K-T
C981	4510008540	S.ELE EEE1CA100SR
C982	4030011600	S.CER C1608 JB 1E 104K-T
C983	4030011600	S.CER C1608 JB 1E 104K-T
C984	4030011600	S.CER C1608 JB 1E 104K-T
C985	4030011600	S.CER C1608 JB 1E 104K-T
C986	4030011600	S.CER C1608 JB 1E 104K-T
C987	4030006860	S.CER C1608 JB 1H 102K-T
C988	4030006870	S.CER C1608 JB 1H 222K-T
C989	4030007140	S.CER C1608 CH 1H 121J-T
C1011	4030006880	S.CER C1608 JB 1H 472K-T
C1012	4030011600	S.CER C1608 JB 1E 104K-T
C1013	4550006930	S.TAN TEESVP 0J 225M8R
C1014	4030006880	S.CER C1608 JB 1H 472K-T
C1015	4030006880	S.CER C1608 JB 1H 472K-T
C1016	4510008540	S.ELE EEE1CA100SR
C1017	4030011600	S.CER C1608 JB 1E 104K-T
C1018	4030010210	S.CER C3216 JB 1C 105M-T
C1019	4030006880	S.CER C1608 JB 1H 472K-T
C1020	4030007110	S.CER C1608 CH 1H 680J-T
C1021	4030007100	S.CER C1608 CH 1H 560J-T
C1022	4610001820	S.TRI TZB4P300AB10R00 (TZBX4P300BA110)
C1023	4030007150	S.CER C1608 CH 1H 151J-T
C1024	4030007150	S.CER C1608 CH 1H 151J-T
C1025	4030007150	S.CER C1608 CH 1H 151J-T
C1026	4030006880	S.CER C1608 JB 1H 472K-T
C1027	4030007010	S.CER C1608 CH 1H 100D-T
C1028	4030006880	S.CER C1608 JB 1H 472K-T
C1029	4030007020	S.CER C1608 CH 1H 120J-T
C1030	4510008540	S.ELE EEE1CA100SR
C1031	4030006880	S.CER C1608 JB 1H 472K-T
C1032	4030006880	S.CER C1608 JB 1H 472K-T
C1033	4030007050	S.CER C1608 CH 1H 220J-T

S.=Surface mount

[MAIN UNIT]

REF NO.	ORDER NO.	DESCRIPTION
C1041	4030010210	S.CER C3216 JB 1C 105M-T
C1042	4030012610	S.CER C2012 JB 1C 474K-T except [USA], [USA-1], [EUR], [EUR-1]
C1043	4030011600	S.CER C1608 JB 1E 104K-T
C1044	4030006880	S.CER C1608 JB 1H 472K-T
C1045	4510008540	S.ELE EEE1CA100SR
C1046	4030011600	S.CER C1608 JB 1E 104K-T
C1047	4510008540	S.ELE EEE1CA100SR
C1048	4030011600	S.CER C1608 JB 1E 104K-T
C1049	4030006880	S.CER C1608 JB 1H 472K-T
C1050	4030006880	S.CER C1608 JB 1H 472K-T
C1051	4030011600	S.CER C1608 JB 1E 104K-T
C1052	4030011600	S.CER C1608 JB 1E 104K-T
C1053	4510008540	S.ELE EEE1CA100SR
C1061	4510008540	S.ELE EEE1CA100SR
C1091	4510008540	S.ELE EEE1CA100SR
C1094	4030010210	S.CER C3216 JB 1C 105M-T
C1095	4030006880	S.CER C1608 JB 1H 472K-T
C1096	4030009990	S.CER C1608 CH 1H 200J-T
C1141	4030012610	S.CER C2012 JB 1C 474K-T
C1142	4030006880	S.CER C1608 JB 1H 472K-T
C1143	4510008540	S.ELE EEE1CA100SR
C1144	4030011600	S.CER C1608 JB 1E 104K-T
C1145	4030012610	S.CER C2012 JB 1C 474K-T
C1161	4030012610	S.CER C2012 JB 1C 474K-T
C1162	4030011600	S.CER C1608 JB 1E 104K-T
C1163	4030011600	S.CER C1608 JB 1E 104K-T
C1164	4030011600	S.CER C1608 JB 1E 104K-T
C1165	4030011600	S.CER C1608 JB 1E 104K-T
C1381	4030006880	S.CER C1608 JB 1H 472K-T
C1382	4030006880	S.CER C1608 JB 1H 472K-T
C1390	4030006860	S.CER C1608 JB 1H 102K-T
C1391	4030006880	S.CER C1608 JB 1H 472K-T
C1394	4030006880	S.CER C1608 JB 1H 472K-T
C1397	4030006880	S.CER C1608 JB 1H 472K-T
C1410	4030006880	S.CER C1608 JB 1H 472K-T
C1421	4030006850	S.CER C1608 JB 1H 471K-T
C1426	4030006880	S.CER C1608 JB 1H 472K-T
C1427	4030006880	S.CER C1608 JB 1H 472K-T
C1428	4030006880	S.CER C1608 JB 1H 472K-T
C2001	4030006880	S.CER C1608 JB 1H 472K-T
C2002	4030006880	S.CER C1608 JB 1H 472K-T
C2003	4030006880	S.CER C1608 JB 1H 472K-T
C2004	4030011600	S.CER C1608 JB 1E 104K-T
C2011	4030007090	S.CER C1608 CH 1H 470J-T
C2012	4030007090	S.CER C1608 CH 1H 470J-T
C2013	4030006880	S.CER C1608 JB 1H 472K-T
C2014	4030006880	S.CER C1608 JB 1H 472K-T
C2016	4030006880	S.CER C1608 JB 1H 472K-T
C2017	4030006880	S.CER C1608 JB 1H 472K-T
C2018	4030006880	S.CER C1608 JB 1H 472K-T
C2019	4030006880	S.CER C1608 JB 1H 472K-T
C2022	4030006880	S.CER C1608 JB 1H 472K-T
C2041	4030006880	S.CER C1608 JB 1H 472K-T
C2042	4030006880	S.CER C1608 JB 1H 472K-T
C2044	4030006880	S.CER C1608 JB 1H 472K-T
C2059	4030011600	S.CER C1608 JB 1E 104K-T
C2061	4030007170	S.CER C1608 CH 1H 221J-T except [EUR], [FRA], [ESP], [USA], [EUR-1], [ESP-1], [USA-1]
C2062	4030007090	S.CER C1608 CH 1H 470J-T
C2063	4030007170	S.CER C1608 CH 1H 221J-T except [EUR], [FRA], [ESP], [USA], [EUR-1], [ESP-1], [USA-1]
C2064	4030007090	S.CER C1608 CH 1H 470J-T
C2065	4030007090	S.CER C1608 CH 1H 470J-T
C2066	4030011600	S.CER C1608 JB 1E 104K-T
C2071	4030006880	S.CER C1608 JB 1H 472K-T
C2072	4030006880	S.CER C1608 JB 1H 472K-T
C2073	4030006880	S.CER C1608 JB 1H 472K-T
C2074	4030006880	S.CER C1608 JB 1H 472K-T
C2075	4030006880	S.CER C1608 JB 1H 472K-T
C2076	4030009590	S.CER C2012 JF 1C 225Z-T
C2081	4030006880	S.CER C1608 JB 1H 472K-T
C2082	4030006880	S.CER C1608 JB 1H 472K-T
C2083	4030006880	S.CER C1608 JB 1H 472K-T
C2084	4030006880	S.CER C1608 JB 1H 472K-T
C2085	4030006880	S.CER C1608 JB 1H 472K-T
C2086	4030012610	S.CER C2012 JB 1C 474K-T
C2101	4030011600	S.CER C1608 JB 1E 104K-T
C2121	4030011600	S.CER C1608 JB 1E 104K-T
C2122	4030011600	S.CER C1608 JB 1E 104K-T
C2123	4030007090	S.CER C1608 CH 1H 470J-T
C2131	4030011600	S.CER C1608 JB 1E 104K-T
C2141	4030006880	S.CER C1608 JB 1H 472K-T
C2142	4030006880	S.CER C1608 JB 1H 472K-T
C2143	4030006880	S.CER C1608 JB 1H 472K-T
C2144	4030006880	S.CER C1608 JB 1H 472K-T
C2145	4030006880	S.CER C1608 JB 1H 472K-T
C2146	4030006880	S.CER C1608 JB 1H 472K-T
C2147	4030006850	S.CER C1608 JB 1H 471K-T
C2161	4030007020	S.CER C1608 CH 1H 120J-T
C2162	4030007020	S.CER C1608 CH 1H 120J-T
C2163	4030011600	S.CER C1608 JB 1E 104K-T
C2164	4030008890	S.CER C1608 JB 1H 273K-T
C2165	4030006880	S.CER C1608 JB 1H 472K-T
C2166	4030011600	S.CER C1608 JB 1E 104K-T
C2181	4030010210	S.CER C3216 JB 1C 105M-T
C2201	4030011600	S.CER C1608 JB 1E 104K-T
C2202	4030011600	S.CER C1608 JB 1E 104K-T
C2221	4030011600	S.CER C1608 JB 1E 104K-T
C2222	4030011600	S.CER C1608 JB 1E 104K-T
C2223	4030007090	S.CER C1608 CH 1H 470J-T
C2232	4030011600	S.CER C1608 JB 1E 104K-T
C2233	4030011600	S.CER C1608 JB 1E 104K-T
C2234	4030011600	S.CER C1608 JB 1E 104K-T

[MAIN UNIT]

REF NO.	ORDER NO.	DESCRIPTION
C2235	4030006850	S.CER C1608 JB 1H 471K-T
C2236	4030006850	S.CER C1608 JB 1H 471K-T
C2237	4030006850	S.CER C1608 JB 1H 471K-T
C2238	4030006850	S.CER C1608 JB 1H 471K-T
C2239	4030006860	S.CER C1608 JB 1H 102K-T
C2240	4030006860	S.CER C1608 JB 1H 102K-T
C2250	4030006860	S.CER C1608 JB 1H 102K-T
C2251	4030007090	S.CER C1608 CH 1H 470J-T
C2252	4030007090	S.CER C1608 CH 1H 470J-T
C2253	4030006860	S.CER C1608 JB 1H 102K-T
J1	6510021280	S.CNR AXK6S20645P
J101	6510007020	CNR TMP-J01X-V6
J141	6510007020	CNR TMP-J01X-V6
J231	6510007020	CNR TMP-J01X-V6
J281	6510007020	CNR TMP-J01X-V6
J401	6510020081	S.CNR 52808-2071 (2090)
J431	6510020081	S.CNR 52808-2071 (2090)
J461	6510020081	S.CNR 52808-2071 (2090)
J551	6510007020	CNR TMP-J01X-V6
J701	6450001560	CNR PD-72
J702	6450001560	CNR PD-72
J703	6450001560	CNR PD-72
J704	6450001560	CNR PD-72
J705	6510020381	CNR JS0330-SN
J706	6510020381	CNR JS0330-SN
J711	6450001560	CNR PD-72
J712	6450001560	CNR PD-72
J713	6450001560	CNR PD-72
J714	6450001560	CNR PD-72
J715	6510020381	CNR JS0330-SN
J716	6510020381	CNR JS0330-SN
J791	6510018961	S.CNR B2B-PH-SM4-TB (LF) (SN)
J1381	6510019071	S.CNR 52559-3072 (3092)
J1421	6510020091	S.CNR 52808-0871 (0890)
J1431	6510018971	S.CNR B4B-PH-SM4-TB (LF) (SN)
J2061	6510019191	S.CNR 52365-0871
W201	7030003860	S.RES ERJ3GE JPW V
W202	7030003860	S.RES ERJ3GE JPW V
W231	7030008240	S.RES ERJ12Y0R00U
W301	7030003860	S.RES ERJ3GE JPW V
W302	7030000010	S.RES MCR10EZHZ JPW (000)
W303	7030000010	S.RES MCR10EZHZ JPW (000)
W461	7030003860	S.RES ERJ3GE JPW V
W514	7030003860	S.RES ERJ3GE JPW V
W844	7030003860	S.RES ERJ3GE JPW V
W1014	7030003860	S.RES ERJ3GE JPW V except [EUR], [FRA], [ESP], [USA], [EUR-1], [ESP-1], [USA-1]
W1056	7030003860	S.RES ERJ3GE JPW V
W1078	7030003860	S.RES ERJ3GE JPW V
W1094	7030003860	S.RES ERJ3GE JPW V
W1433	7030003860	S.RES ERJ3GE JPW V
W2001	7030003860	S.RES ERJ3GE JPW V
W2061	7030000010	S.RES MCR10EZHZ JPW (000)
W2101	7030003860	S.RES ERJ3GE JPW V

S.=Surface mount



[PLL UNIT]

REF NO.	ORDER NO.	DESCRIPTION
IC101	1140007881	S.IC TC190G08EFG0046JDZ/SC1246A
IC102	1130009581	S.IC TC7W66FU (TE12L,F)
IC201	1110003300	S.IC M5282FP 70CD
IC231	1110003091	IC LA4425A-E
IC271	1180000421	S.IC TA78L05F (TE12R,F)
IC281	1110002031	IC TA7808S (Q)
IC291	1180001071	S.IC TA7805F (TE16L,Q)
IC461	1130009230	S.IC LMX2306TMX/NOPB
IC541	1110003320	S.IC uPC2710T-E3
IC901	1140004550	S.IC M65343FP/SC1287
Q1	1560000331	S.FET 2SK210-GR (TE85R,F)
Q10	1530002571	S.TR 2SC4405-3-TL-E
Q21	1530002060	S.TR 2SC4081 T106 R
Q51	1530002060	S.TR 2SC4081 T106 R
Q71	1530002060	S.TR 2SC4081 T106 R
Q141	1590001330	S.TR DTA114EUA T106
Q142	1590001330	S.TR DTA114EUA T106
Q143	1590001330	S.TR DTA114EUA T106
Q144	1590001330	S.TR DTA114EUA T106
Q145	1590001330	S.TR DTA114EUA T106
Q161	1530002060	S.TR 2SC4081 T106 R
Q232	1590000680	S.TR DTC114EUA T106
Q251	1590000720	S.TR DTA144EUA T106
Q261	1590002310	S.TR DTC114EE TL
Q301	1560000491	S.FET 2SK508-T2B-A K52 [USA] only
Q321	1530003091	S.TR 2SC4213-B (TE85R,F)
Q322	1590000720	S.TR DTA144EUA T106
Q331	1560000491	S.FET 2SK508-T2B-A K52 [USA] only
Q351	1530003091	S.TR 2SC4213-B (TE85R,F)
Q352	1590000720	S.TR DTA144EUA T106
Q361	1560000491	S.FET 2SK508-T2B-A K52 [USA] only
Q362	1530002691	S.TR 2SC4116-GR (TE85R,F)
Q381	1530003091	S.TR 2SC4213-B (TE85R,F)
Q391	1530002691	S.TR 2SC4116-GR (TE85R,F)
Q461	1590000720	S.TR DTA144EUA T106
Q491	1560000541	S.FET 2SK880-Y (T5RICOM,F)
Q521	1590002480	S.TR UMC3N TR
Q621	1530002561	S.TR 2SC4403-3-TL-E
Q661	1530002561	S.TR 2SC4403-3-TL-E
Q681	1530002561	S.TR 2SC4403-3-TL-E
Q851	1590001330	S.TR DTA114EUA T106
Q931	1530002060	S.TR 2SC4081 T106 R
Q941	1530002060	S.TR 2SC4081 T106 R
		except [EUR], [FRA], [ESP], [USA], [EUR-1], [ESP-1], [USA-1]
D1	1720000590	S.VCP MA357 (TX)
D231	1750000520	S.DIO DAN222TL
D261	1750000520	S.DIO DAN222TL
D271	1710000780	S.DIO MA114 (TX)
D301	1720000831	S.VCP KV1770STL-G
D302	1790000620	S.DIO MA77 (TX)
D331	1720000831	S.VCP KV1770STL-G
D332	1790000620	S.DIO MA77 (TX)
D361	1790001400	S.VCP MA304B (TX)
D362	1790000620	S.DIO MA77 (TX)
D511	1790000620	S.DIO MA77 (TX)
D531	1750000620	S.DIO MA717WK (TX)
D601	1720000590	S.VCP MA357 (TX)
D701	1790000450	S.DIO MA862 (TX)
D731	1790000450	S.DIO MA862 (TX)
D732	1790000450	S.DIO MA862 (TX)
D761	1750000211	S.DIO 1SV237 (TE85R,F)
D762	1750000211	S.DIO 1SV237 (TE85R,F)
D821	1790001621	S.DIO 1SV308 (TPL3,F)
D822	1790001621	S.DIO 1SV308 (TPL3,F)
D825	1790001621	S.DIO 1SV308 (TPL3,F)
D851	1790001621	S.DIO 1SV308 (TPL3,F)
D861	1750000211	S.DIO 1SV237 (TE85R,F)
D862	1160000060	S.DIO DAN202U T106
D863	1790001250	S.DIO MA2S111-(TX)
D864	1790001250	S.DIO MA2S111-(TX)
D931	1790001250	S.DIO MA2S111-(TX)
FI71	2020001820	S.CER SFECV10M5FA00-R0 (SFECV10.5MA5S [ESP], [OTH], [ITA], [ITR], [OTH-1], [ITR-1], [CHN], [CHN-01] only)
X621	6050005712	XTL CR-275B (30.000 MHz) [ESP], [OTH], [ITA], [ITR], [OTH-1], [ITR-1], [CHN], [CHN-01] only
L1	6130002970	COL LB-343
L11	6200005011	S.COL NLV25T-100J
L12	6200007830	S.COL ELJFC 4R7K-F
L30	6200002041	S.COL NLV25T-101J
L41	6200003590	S.COL EXCCL3225U1
L42	6200003590	S.COL EXCCL3225U1
L43	6200003590	S.COL EXCCL3225U1
L44	6200003590	S.COL EXCCL3225U1
L45	6200001831	S.COL NLV32T-100J
L48	6200001831	S.COL NLV32T-100J
L71	6200002861	S.COL NLV25T-4R7J
L131	6200001831	S.COL NLV32T-100J
L161	6200002041	S.COL NLV25T-101J
L163	6200007730	S.COL LQW2BHN39NJ03L
L165	6200005180	S.COL MLF1608D R39K-T
L231	6140002220	COL LR-270 (TR6X3X2 3A9)
L238	6200005011	S.COL NLV25T-100J

[PLL UNIT]

REF NO.	ORDER NO.	DESCRIPTION
L251	6200007710	S.COL LQW2BHN27NJ03L
		except [USA], [USA-1], [EUR], [EUR-1]
L301	6170000230	COL LW-25
L302	6190001281	COL #E544GN-110248
L303	6170000230	COL LW-25
L331	6170000230	COL LW-25
L332	6190001371	COL #E544GN-110254
L333	6170000230	COL LW-25
L363	6180000810	COL LAL 03NA 2R2M
L364	6180000810	COL LAL 03NA 2R2M
L366	6190001390	COL C-13975-4.5
L367	6200005011	S.COL NLV25T-100J
L382	6200003261	S.COL NLV32T-101J
L383	6180000810	COL LAL 03NA 2R2M
L391	6200005011	S.COL NLV25T-100J
L411	6140002220	COL LR-270 (TR6X3X2 3A9)
L461	6200005011	S.COL NLV25T-100J
L501	6200001981	S.COL NLV25T-1R0J
L531	6140002810	S.COL LR-317
L532	6200003540	S.COL MLF1608D R22K-T
L542	6200002920	S.COL ELJNC R33K-F
L600	6200002041	S.COL NLV25T-101J
L601	6130001100	COL LB-146
L621	6200003261	S.COL NLV32T-101J
L622	6200003590	S.COL EXCCL3225U1
L623	6150004521	S.COL LS-508-LF
L641	6200002001	S.COL NLV25T-3R3J
L642	6200004671	S.COL NLV25T-3R9J
L681	6150004831	S.COL LS-509-LF
L682	6150004831	S.COL LS-509-LF
L711	6200002160	S.COL ELJNC 82NK-F
L712	6200001630	S.COL ELJNC R10K-F
L713	6200002160	S.COL ELJNC 82NK-F
L741	6200002150	S.COL ELJNC 56NK-F
L742	6200003670	S.COL ELJNC 68NK-F
L743	6200003670	S.COL ELJNC 68NK-F
L771	6200002160	S.COL ELJNC 82NK-F
L781	6200001770	S.COL ELJNC 47NK-F
L782	6200002120	S.COL ELJNC 33NK-F
L801	6200005741	S.COL ELJRE 47NGFA
L802	6200005721	S.COL ELJRE 33NGFA
L811	6200005711	S.COL ELJRE 27NGFA
L812	6200005721	S.COL ELJRE 33NGFA
L821	6200007740	S.COL LQW2BHN47NJ03L
L822	6200007720	S.COL LQW2BHN33NJ03L
L823	6200007730	S.COL LQW2BHN39NJ03L
L824	6200007710	S.COL LQW2BHN27NJ03L
L861	6200005701	S.COL ELJRE 22NGFA
L862	6200005681	S.COL ELJRE 15NGFA
L871	6200005681	S.COL ELJRE 15NGFA
L872	6200005671	S.COL ELJRE 12NGFA
L881	6200002651	S.COL NLV25T-R18J
L882	6200005661	S.COL ELJRE 10NGFA
L901	6200005011	S.COL NLV25T-100J
L941	6200008080	S.COL LQW2BHN22J03L
L981	6200003171	S.COL NLV32T-330J
L991	6200007390	S.COL ELJFC 120K-F
L992	6200006380	S.COL ELJFC 150K
L1000	6200006981	S.COL ELJRE R10GFA
L1001	2040000490	COL EXC-ELDR25C
L1016	6200005011	S.COL NLV25T-100J
R11	7030003280	S.RES ERJ3GEYJ 470 V (47)
R12	7030003320	S.RES ERJ3GEYJ 101 V (100)
R13	7030003680	S.RES ERJ3GEYJ 104 V (100 k)
R14	7030003680	S.RES ERJ3GEYJ 104 V (100 k)
R15	7030003340	S.RES ERJ3GEYJ 151 V (150)
R16	7030003520	S.RES ERJ3GEYJ 472 V (4.7 k)
R21	7030003640	S.RES ERJ3GEYJ 473 V (47 k)
R23	7030003320	S.RES ERJ3GEYJ 101 V (100)
R24	7030003370	S.RES ERJ3GEYJ 271 V (270)
R32	7030003420	S.RES ERJ3GEYJ 681 V (680)
R41	7030003220	S.RES ERJ3GEYJ 150 V (15)
R52	7030003280	S.RES ERJ3GEYJ 470 V (47)
R53	7030003370	S.RES ERJ3GEYJ 271 V (270)
R54	7030003660	S.RES ERJ3GEYJ 683 V (68 k)
R71	7030003280	S.RES ERJ3GEYJ 470 V (47)
R72	7030003360	S.RES ERJ3GEYJ 221 V (220)
R73	7030003640	S.RES ERJ3GEYJ 473 V (47 k)
		except [EUR], [FRA], [USA]
R75	7030003400	S.RES ERJ3GEYJ 471 V (470)
R76	7030003360	S.RES ERJ3GEYJ 221 V (220)
R101	7030003440	S.RES ERJ3GEYJ 102 V (1 k)
R102	7030003440	S.RES ERJ3GEYJ 102 V (1 k)
R103	7030003440	S.RES ERJ3GEYJ 102 V (1 k)
R104	7030003440	S.RES ERJ3GEYJ 102 V (1 k)
R105	7030003440	S.RES ERJ3GEYJ 102 V (1 k)
R106	7030003440	S.RES ERJ3GEYJ 102 V (1 k)
R131	7030003440	S.RES ERJ3GEYJ 102 V (1 k)
		except [USA], [USA-1], [EUR], [EUR-1]
R133	7030009690	S.RES RR0816P-101-D (100)
R134	7030005730	S.RES RR0816R-823-D (82 k)
R135	7030005390	S.RES RR0816P-102-D (1 k)
R136	7030003440	S.RES ERJ3GEYJ 102 V (1 k)
		except [EUR], [FRA], [ESP], [USA], [EUR-1], [ESP-1], [USA-1]
R137	7030003440	S.RES ERJ3GEYJ 102 V (1 k)
		except [EUR], [FRA], [ESP], [USA], [EUR-1], [ESP-1], [USA-1]
R138	7030003320	S.RES ERJ3GEYJ 101 V (100)
		except [EUR], [FRA], [ESP], [USA], [EUR-1], [ESP-1], [USA-1]
R141	7030003440	S.RES ERJ3GEYJ 102 V (1 k)
R142	7030003440	S.RES ERJ3GEYJ 102 V (1 k)
R143	7030003440	S.RES ERJ3GEYJ 102 V (1 k)

S.=Surface mount

[PLL UNIT]

REF NO.	ORDER NO.	DESCRIPTION
R144	7030003440	S.RES ERJ3GEYJ 102 V (1 k)
R145	7030003440	S.RES ERJ3GEYJ 102 V (1 k)
R151	7030003560	S.RES ERJ3GEYJ 103 V (10 k)
R152	7030003560	S.RES ERJ3GEYJ 103 V (10 k)
R153	7030003560	S.RES ERJ3GEYJ 103 V (10 k)
R154	7030003560	S.RES ERJ3GEYJ 103 V (10 k)
R155	7030003560	S.RES ERJ3GEYJ 103 V (10 k)
R161	7030003350	S.RES ERJ3GEYJ 181 V (180)
R162	7030003640	S.RES ERJ3GEYJ 473 V (47 k) except [EUR], [FRA], [USA], [EUR-1], [FRA-1], [ESP-1], [USA-1]
R163	7030003350	S.RES ERJ3GEYJ 181 V (180)
R170	7030005370	S.RES RR0816P-202-B (2 k)
R171	7030005380	S.RES RR0816P-102-B (1 k)
R172	7030005370	S.RES RR0816P-202-B (2 k)
R173	7030005380	S.RES RR0816P-102-B (1 k)
R174	7030005370	S.RES RR0816P-202-B (2 k)
R175	7030005380	S.RES RR0816P-102-B (1 k)
R176	7030005370	S.RES RR0816P-202-B (2 k)
R177	7030005380	S.RES RR0816P-102-B (1 k)
R178	7030005370	S.RES RR0816P-202-B (2 k)
R179	7030005380	S.RES RR0816P-102-B (1 k)
R180	7030005400	S.RES RR0816P-202-D (2 k)
R181	7030005390	S.RES RR0816P-102-D (1 k)
R182	7030005400	S.RES RR0816P-202-D (2 k)
R183	7030005390	S.RES RR0816P-102-D (1 k)
R184	7030005400	S.RES RR0816P-202-D (2 k)
R185	7030005390	S.RES RR0816P-102-D (1 k)
R186	7030005400	S.RES RR0816P-202-D (2 k)
R187	7030005390	S.RES RR0816P-102-D (1 k)
R188	7030005400	S.RES RR0816P-202-D (2 k)
R189	7030005390	S.RES RR0816P-102-D (1 k)
R190	7030005400	S.RES RR0816P-202-D (2 k)
R191	7030005390	S.RES RR0816P-102-D (1 k)
R192	7030005400	S.RES RR0816P-202-D (2 k)
R193	7030005400	S.RES RR0816P-202-D (2 k)
R201	7030003640	S.RES ERJ3GEYJ 473 V (47 k)
R202	7030003560	S.RES ERJ3GEYJ 103 V (10 k)
R203	7030003560	S.RES ERJ3GEYJ 103 V (10 k)
R204	7030003720	S.RES ERJ3GEYJ 224 V (220 k)
R205	7030003440	S.RES ERJ3GEYJ 102 V (1 k)
R206	7030003440	S.RES ERJ3GEYJ 102 V (1 k)
R207	7030003560	S.RES ERJ3GEYJ 103 V (10 k)
R208	7030003480	S.RES ERJ3GEYJ 222 V (2.2 k)
R209	7030003480	S.RES ERJ3GEYJ 222 V (2.2 k)
R231	7510001571	S.TMR NTCG16 4LH 104JT
R232	7030003560	S.RES ERJ3GEYJ 103 V (10 k)
R233	7030003440	S.RES ERJ3GEYJ 102 V (1 k)
R234	7030003400	S.RES ERJ3GEYJ 471 V (470)
R235	7030000100	S.RES MCR10EZHJ 4.7 (4R7)
R236	7030003550	S.RES ERJ3GEYJ 822 V (8.2 k)
R237	7030008000	S.RES ERJ1WYJ3R3U (3.3)
R238	7030003440	S.RES ERJ3GEYJ 102 V (1 k) except [USA], [USA-1], [EUR], [EUR-1]
R251	7030003440	S.RES ERJ3GEYJ 102 V (1 k)
R252	7030003440	S.RES ERJ3GEYJ 102 V (1 k)
R253	7030003440	S.RES ERJ3GEYJ 102 V (1 k)
R254	7030003440	S.RES ERJ3GEYJ 102 V (1 k)
R255	7030003440	S.RES ERJ3GEYJ 102 V (1 k)
R256	7030003440	S.RES ERJ3GEYJ 102 V (1 k)
R257	7030003440	S.RES ERJ3GEYJ 102 V (1 k)
R258	7030003440	S.RES ERJ3GEYJ 102 V (1 k)
R259	7030003440	S.RES ERJ3GEYJ 102 V (1 k)
R260	7030003440	S.RES ERJ3GEYJ 102 V (1 k)
R261	7030003640	S.RES ERJ3GEYJ 473 V (47 k)
R263	7030003440	S.RES ERJ3GEYJ 102 V (1 k)
R264	7030003440	S.RES ERJ3GEYJ 102 V (1 k)
R265	7030003610	S.RES ERJ3GEYJ 273 V (27 k)
R283	7510001470	S.TMR NTCG20 4AG 473JT
R284	7030003420	S.RES ERJ3GEYJ 681 V (680)
R285	7030003440	S.RES ERJ3GEYJ 102 V (1 k)
R291	7030006080	S.RES ERJ1WYJ220U (22)
R292	7030006080	S.RES ERJ1WYJ220U (22)
R302	7030003360	S.RES ERJ3GEYJ 221 V (220)
R321	7030003380	S.RES ERJ3GEYJ 331 V (330)
R322	7030003560	S.RES ERJ3GEYJ 103 V (10 k)
R323	7030003520	S.RES ERJ3GEYJ 472 V (4.7 k)
R324	7030003440	S.RES ERJ3GEYJ 102 V (1 k)
R325	7030003560	S.RES ERJ3GEYJ 103 V (10 k)
R332	7030003320	S.RES ERJ3GEYJ 101 V (100)
R351	7030003340	S.RES ERJ3GEYJ 151 V (150)
R352	7030003560	S.RES ERJ3GEYJ 103 V (10 k)
R353	7030003520	S.RES ERJ3GEYJ 472 V (4.7 k)
R354	7030003440	S.RES ERJ3GEYJ 102 V (1 k)
R355	7030003560	S.RES ERJ3GEYJ 103 V (10 k)
R356	7030003300	S.RES ERJ3GEYJ 680 V (68)
R361	7030003300	S.RES ERJ3GEYJ 680 V (68)
R364	7030003560	S.RES ERJ3GEYJ 103 V (10 k)
R365	7030003560	S.RES ERJ3GEYJ 103 V (10 k)
R381	7030003380	S.RES ERJ3GEYJ 331 V (330)
R382	7030003560	S.RES ERJ3GEYJ 103 V (10 k)
R383	7030003520	S.RES ERJ3GEYJ 472 V (4.7 k)
R384	7030003560	S.RES ERJ3GEYJ 103 V (10 k)
R385	7030003560	S.RES ERJ3GEYJ 103 V (10 k)
R391	7030003560	S.RES ERJ3GEYJ 103 V (10 k)
R392	7030003560	S.RES ERJ3GEYJ 103 V (10 k)
R411	7030009690	S.RES RR0816P-101-D (100)
R412	7030006580	S.RES RR0816P-122-D (1.2 k)
R461	7030003680	S.RES ERJ3GEYJ 104 V (100 k)
R462	7030003440	S.RES ERJ3GEYJ 102 V (1 k)
R463	7030003440	S.RES ERJ3GEYJ 102 V (1 k)
R464	7030003440	S.RES ERJ3GEYJ 102 V (1 k)
R465	7030003680	S.RES ERJ3GEYJ 104 V (100 k)

[PLL UNIT]

REF NO.	ORDER NO.	DESCRIPTION
R466	7030003290	S.RES ERJ3GEYJ 560 V (56) [OTH], [ITA], [ITR], [OTH-1], [ITA-1], [ITR-1], [CHN], [CHN-01] only
R471	7030003300	S.RES ERJ3GEYJ 680 V (68) [OTH], [ITA], [ITR], [OTH-1], [ITA-1], [ITR-1], [CHN], [CHN-01] only
R491	7030003320	S.RES ERJ3GEYJ 101 V (100)
R492	7030003680	S.RES ERJ3GEYJ 104 V (100 k)
R493	7030003680	S.RES ERJ3GEYJ 104 V (100 k)
R494	7030003800	S.RES ERJ3GEYJ 105 V (1 M)
R501	7030003260	S.RES ERJ3GEYJ 330 V (33)
R502	7030003520	S.RES ERJ3GEYJ 472 V (4.7 k)
R511	7030003550	S.RES ERJ3GEYJ 822 V (8.2 k)
R512	7030003510	S.RES ERJ3GEYJ 392 V (3.9 k)
R513	7030003320	S.RES ERJ3GEYJ 101 V (100)
R515	7030003350	S.RES ERJ3GEYJ 181 V (180) [OTH], [ITA], [ITR], [OTH-1], [ITA-1], [ITR-1], [CHN], [CHN-01] only
R517	7030003230	S.RES ERJ3GEYJ 180 V (18)
R518	7030003370	S.RES ERJ3GEYJ 271 V (270)
R523	7030003440	S.RES ERJ3GEYJ 102 V (1 k)
R524	7030003200	S.RES ERJ3GEYJ 100 V (10)
R531	7030003340	S.RES ERJ3GEYJ 151 V (150)
R532	7030003270	S.RES ERJ3GEYJ 390 V (39)
R533	7030003340	S.RES ERJ3GEYJ 151 V (150)
R537	7030003370	S.RES ERJ3GEYJ 271 V (270)
R538	7030003230	S.RES ERJ3GEYJ 180 V (18)
R539	7030003370	S.RES ERJ3GEYJ 271 V (270)
R541	7030003360	S.RES ERJ3GEYJ 221 V (22)
R542	7030003240	S.RES ERJ3GEYJ 220 V (22)
R601	7030003440	S.RES ERJ3GEYJ 102 V (1 k)
R602	7310005020	S.TRI RH03ADC14X (10 k)
R603	7030003440	S.RES ERJ3GEYJ 102 V (1 k)
R604	7030003440	S.RES ERJ3GEYJ 102 V (1 k)
R605	7030003640	S.RES ERJ3GEYJ 473 V (47 k)
R606	7030003200	S.RES ERJ3GEYJ 100 V (10)
R621	7030003580	S.RES ERJ3GEYJ 153 V (15 k)
R622	7030003520	S.RES ERJ3GEYJ 472 V (4.7 k)
R623	7030003400	S.RES ERJ3GEYJ 471 V (470)
R641	7030003360	S.RES ERJ3GEYJ 221 V (220)
R661	7030003320	S.RES ERJ3GEYJ 101 V (100)
R662	7030003450	S.RES ERJ3GEYJ 122 V (1.2 k)
R663	7030003480	S.RES ERJ3GEYJ 222 V (2.2 k)
R666	7030003340	S.RES ERJ3GEYJ 151 V (150)
R667	7030003360	S.RES ERJ3GEYJ 221 V (220) except [USA], [USA-1], [EUR], [EUR-1]
R681	7030003320	S.RES ERJ3GEYJ 101 V (100)
R682	7030003600	S.RES ERJ3GEYJ 223 V (22 k)
R683	7030003560	S.RES ERJ3GEYJ 103 V (10 k)
R684	7030003360	S.RES ERJ3GEYJ 221 V (220)
R701	7030003440	S.RES ERJ3GEYJ 102 V (1 k)
R731	7030003440	S.RES ERJ3GEYJ 102 V (1 k)
R761	7030003440	S.RES ERJ3GEYJ 102 V (1 k)
R762	7030003320	S.RES ERJ3GEYJ 101 V (100)
R791	7030003440	S.RES ERJ3GEYJ 102 V (1 k)
R792	7030003440	S.RES ERJ3GEYJ 102 V (1 k)
R821	7030003360	S.RES ERJ3GEYJ 221 V (220)
R822	7030003440	S.RES ERJ3GEYJ 102 V (1 k)
R823	7030003440	S.RES ERJ3GEYJ 102 V (1 k)
R824	7030003440	S.RES ERJ3GEYJ 102 V (1 k)
R825	7030003560	S.RES ERJ3GEYJ 103 V (10 k)
R851	7030003330	S.RES ERJ3GEYJ 121 V (120)
R852	7030003440	S.RES ERJ3GEYJ 102 V (1 k)
R853	7030003440	S.RES ERJ3GEYJ 102 V (1 k)
R854	7030003330	S.RES ERJ3GEYJ 121 V (120)
R855	7030003270	S.RES ERJ3GEYJ 390 V (39)
R891	7030003340	S.RES ERJ3GEYJ 151 V (150)
R892	7030003270	S.RES ERJ3GEYJ 390 V (39)
R893	7030003340	S.RES ERJ3GEYJ 151 V (150)
R901	7030003440	S.RES ERJ3GEYJ 102 V (1 k)
R902	7030003440	S.RES ERJ3GEYJ 102 V (1 k)
R903	7030003440	S.RES ERJ3GEYJ 102 V (1 k)
R931	7030003520	S.RES ERJ3GEYJ 472 V (4.7 k)
R932	7030003620	S.RES ERJ3GEYJ 333 V (33 k)
R933	7030003580	S.RES ERJ3GEYJ 153 V (15 k)
R934	7030003480	S.RES ERJ3GEYJ 221 V (2.2 k)
R941	7030003320	S.RES ERJ3GEYJ 101 V (100) except [EUR], [FRA], [ESP], [USA], [EUR-1], [ESP-1], [USA-1]
R942	7030003640	S.RES ERJ3GEYJ 473 V (47 k) except [EUR], [FRA], [ESP], [USA], [EUR-1], [ESP-1], [USA-1]
R943	7030003370	S.RES ERJ3GEYJ 271 V (270) except [EUR], [FRA], [ESP], [USA], [EUR-1], [ESP-1], [USA-1]
R951	7030005370	S.RES RR0816P-202-B (2 k)
R952	7030005380	S.RES RR0816P-102-B (1 k)
R953	7030005370	S.RES RR0816P-202-B (2 k)
R954	7030005380	S.RES RR0816P-102-B (1 k)
R955	7030005370	S.RES RR0816P-202-B (2 k)
R956	7030005380	S.RES RR0816P-102-B (1 k)
R957	7030005400	S.RES RR0816P-202-D (2 k)
R958	7030005390	S.RES RR0816P-102-D (1 k)
R959	7030005400	S.RES RR0816P-202-D (2 k)
R960	7030005390	S.RES RR0816P-102-D (1 k)
R961	7030005400	S.RES RR0816P-202-D (2 k)
R962	7030005390	S.RES RR0816P-102-D (1 k)
R963	7030005400	S.RES RR0816P-202-D (2 k)
R964	7030005390	S.RES RR0816P-102-D (1 k)
R965	7030005400	S.RES RR0816P-202-D (2 k)
R966	7030005390	S.RES RR0816P-102-D (1 k)
R967	7030005400	S.RES RR0816P-202-D (2 k)
R968	7030005390	S.RES RR0816P-102-D (1 k)
R969	7030005400	S.RES RR0816P-202-D (2 k)
R970	7030005400	S.RES RR0816P-202-D (2 k)
R1011	7030003400	S.RES ERJ3GEYJ 471 V (470)
R1012	7030003400	S.RES ERJ3GEYJ 471 V (470)
R1013	7030003400	S.RES ERJ3GEYJ 471 V (470)
R1014	7030003400	S.RES ERJ3GEYJ 471 V (470)
R1015	7030003400	S.RES ERJ3GEYJ 471 V (470)

S.=Surface mount



[PLL UNIT]

REF NO.	ORDER NO.	DESCRIPTION
R1017	7030003400	S.RES ERJ3GEYJ 471 V (470)
C1	4020001020	CYR UP050 B 103K-NA-CZ
C2	4030008560	S.CER C1608 CH 1H 300J-T
C3	4030006950	S.CER C1608 CH 1H 040C-T
C4	4610001850	S.TRI TZB4R200AB10R00 (TZB4R200BA110)
C5	4030016550	S.CER CM105 CH 151G 50AT
C11	4510008490	S.ELE EEE1CS100SR
C12	4030006880	S.CER C1608 JB 1H 472K-T
C13	4030006880	S.CER C1608 JB 1H 472K-T
C14	4030016550	S.CER CM105 CH 151G 50AT
C15	4030016550	S.CER CM105 CH 151G 50AT
C21	4030009530	S.CER C1608 CH 1H 030B-T
C22	4030011600	S.CER C1608 JB 1E 104K-T
C31	4030006880	S.CER C1608 JB 1H 472K-T
C33	4030007090	S.CER C1608 CH 1H 470J-T except [EUR], [FRA], [USA]
C34	4030007090	S.CER C1608 CH 1H 470J-T except [EUR], [FRA], [USA]
C35	4030007020	S.CER C1608 CH 1H 120J-T except [EUR], [FRA], [USA]
C41	4030006880	S.CER C1608 JB 1H 472K-T
C44	4030006880	S.CER C1608 JB 1H 472K-T
C45	4030008680	S.CER C2012 JF 1C 105Z-T
C51	4030007090	S.CER C1608 CH 1H 470J-T except [USA], [USA-1], [EUR], [EUR-1]
C52	4030006880	S.CER C1608 JB 1H 472K-T
C71	4030006880	S.CER C1608 JB 1H 472K-T
C72	4030011600	S.CER C1608 JB 1E 104K-T
C73	4030007050	S.CER C1608 CH 1H 220J-T
C75	4030006880	S.CER C1608 JB 1H 472K-T
C76	4030007090	S.CER C1608 CH 1H 470J-T
C77	4030007090	S.CER C1608 CH 1H 470J-T
C101	4030011600	S.CER C1608 JB 1E 104K-T
C102	4030011600	S.CER C1608 JB 1E 104K-T
C103	4030011600	S.CER C1608 JB 1E 104K-T
C104	4030011600	S.CER C1608 JB 1E 104K-T
C105	4030011600	S.CER C1608 JB 1E 104K-T
C106	4030011600	S.CER C1608 JB 1E 104K-T
C107	4030011600	S.CER C1608 JB 1E 104K-T
C108	4030011600	S.CER C1608 JB 1E 104K-T
C109	4030011600	S.CER C1608 JB 1E 104K-T
C110	4030011600	S.CER C1608 JB 1E 104K-T
C111	4030011600	S.CER C1608 JB 1E 104K-T
C112	4030011600	S.CER C1608 JB 1E 104K-T
C113	4030011600	S.CER C1608 JB 1E 104K-T
C114	4030011600	S.CER C1608 JB 1E 104K-T
C131	4030006880	S.CER C1608 JB 1H 472K-T
C132	4030006880	S.CER C1608 JB 1H 472K-T [ESP], [OTH], [ITA], [ITR], [OTH-1], [ITR-1], [CHN], [CHN-01] only
C133	4550003220	S.TAN TEESVA 1E 105M8R
C145	4030006880	S.CER C1608 JB 1H 472K-T
C146	4030006880	S.CER C1608 JB 1H 472K-T
C147	4030006880	S.CER C1608 JB 1H 472K-T
C148	4030006880	S.CER C1608 JB 1H 472K-T
C149	4030006880	S.CER C1608 JB 1H 472K-T
C150	4030006880	S.CER C1608 JB 1H 472K-T
C151	4030006880	S.CER C1608 JB 1H 472K-T
C152	4030006880	S.CER C1608 JB 1H 472K-T
C153	4030006880	S.CER C1608 JB 1H 472K-T
C154	4030006880	S.CER C1608 JB 1H 472K-T
C155	4030006880	S.CER C1608 JB 1H 472K-T
C156	4030006880	S.CER C1608 JB 1H 472K-T [ESP], [OTH], [ITA], [ITR], [OTH-1], [ITR-1], [CHN], [CHN-01] only
C161	4030006880	S.CER C1608 JB 1H 472K-T
C162	4030007050	S.CER C1608 CH 1H 220J-T except [EUR], [FRA], [ESP], [USA], [EUR-1], [ESP-1], [USA-1]
C163	4030006900	S.CER C1608 JB 1H 103K-T except [EUR], [FRA], [ESP], [USA], [EUR-1], [ESP-1], [USA-1]
C165	4030007150	S.CER C1608 CH 1H 151J-T
C167	4030007090	S.CER C1608 CH 1H 470J-T
C171	4030007060	S.CER C1608 CH 1H 270J-T except [USA], [USA-1], [EUR], [EUR-1]
C172	4030007010	S.CER C1608 CH 1H 100D-T except [USA], [USA-1], [EUR], [EUR-1]
C173	4030006960	S.CER C1608 CH 1H 050C-T except [USA], [USA-1], [EUR], [EUR-1]
C174	4030011600	S.CER C1608 JB 1E 104K-T except [USA], [USA-1], [EUR], [EUR-1]
C175	4030006880	S.CER C1608 JB 1H 472K-T except [USA], [USA-1], [EUR], [EUR-1]
C176	4030006880	S.CER C1608 JB 1H 472K-T except [USA], [USA-1], [EUR], [EUR-1]
C200	4030011340	S.CER C1608 CH 1H 471J-T except [EUR], [FRA], [USA]
C201	4550006080	S.TAN TEESVB2 1C 106M8R
C202	4030009110	S.CER C3216 JB 1C 474K-T
C203	4030011600	S.CER C1608 JB 1E 104K-T
C204	4030007170	S.CER C1608 CH 1H 221J-T
C205	4030009110	S.CER C3216 JB 1C 474K-T
C206	4550006080	S.TAN TEESVB2 1C 106M8R
C207	4030009110	S.CER C3216 JB 1C 474K-T
C208	4030010210	S.CER C3216 JB 1C 105M-T
C209	4550006080	S.TAN TEESVB2 1C 106M8R
C210	4030006860	S.CER C1608 JB 1H 102K-T
C212	4030006880	S.CER C1608 JB 1H 472K-T
C215	4030007090	S.CER C1608 CH 1H 470J-T
C218	4030006860	S.CER C2012 JF 1C 105Z-T
C220	4030007090	S.CER C1608 CH 1H 470J-T
C221	4030006880	S.CER C1608 JB 1H 472K-T
C222	4030007090	S.CER C1608 CH 1H 470J-T
C223	4030007090	S.CER C1608 CH 1H 470J-T
C224	4030007090	S.CER C1608 CH 1H 470J-T
C225	4030007090	S.CER C1608 CH 1H 470J-T
C231	4510004591	ELE 16 ME 470 HC
C232	4030009110	S.CER C3216 JB 1C 474K-T
C233	4030006880	S.CER C1608 JB 1H 472K-T
C234	4030011600	S.CER C1608 JB 1E 104K-T
C235	4510004591	ELE 16 ME 470 HC

[PLL UNIT]

REF NO.	ORDER NO.	DESCRIPTION
C236	4510004591	ELE 16 ME 470 HC
C237	4030011600	S.CER C1608 JB 1E 104K-T
C238	4030006880	S.CER C1608 JB 1H 472K-T
C239	4030011600	S.CER C1608 JB 1E 104K-T
C240	4030011600	S.CER C1608 JB 1E 104K-T
C241	4030011600	S.CER C1608 JB 1E 104K-T
C251	4030006860	S.CER C1608 JB 1H 102K-T
C256	4030011600	S.CER C1608 JB 1E 104K-T
C257	4030007070	S.CER C1608 CH 1H 330J-T except [EUR], [FRA], [ESP], [USA], [EUR-1], [ESP-1], [USA-1]
C261	4030011600	S.CER C1608 JB 1E 104K-T [ESP], [OTH], [ITA], [ITR], [OTH-1], [ITR-1], [CHN], [CHN-01] only
C262	4030006860	S.CER C1608 JB 1H 102K-T
C265	4030006860	S.CER C1608 JB 1H 102K-T
C271	4510008490	S.ELE EEE1CS100SR
C272	4030006880	S.CER C1608 JB 1H 472K-T
C273	4030006880	S.CER C1608 JB 1H 472K-T
C274	4510008490	S.ELE EEE1CS100SR
C281	4030006880	S.CER C1608 JB 1H 472K-T
C284	4510008490	S.ELE EEE1CS100SR
C285	4030006880	S.CER C1608 JB 1H 472K-T
C286	4030011600	S.CER C1608 JB 1E 104K-T
C291	4510008490	S.ELE EEE1CS100SR
C292	4030006880	S.CER C1608 JB 1H 472K-T
C293	4030006880	S.CER C1608 JB 1H 472K-T
C294	4510008490	S.ELE EEE1CS100SR
C295	4510001350	ELE 16 MS5 10UF
C296	4030011600	S.CER C1608 JB 1E 104K-T [OTH], [ITA], [ITR], [OTH-1], [ITA-1], [ITR-1], [CHN], [CHN-01] only
C301	4030008470	S.CER C1608 JB 1H 272K-T [ESP], [OTH], [ITA], [ITR], [OTH-1], [ITR-1], [CHN], [CHN-01] only
C302	4030006850	S.CER C1608 JB 1H 471K-T
C303	4030008470	S.CER C1608 JB 1H 272K-T [OTH], [ITA], [ITR], [OTH-1], [ITR-1], [CHN], [CHN-01] only
C304	4030009510	S.CER C1608 CH 1H 010B-T
C305	4030006850	S.CER C1608 JB 1H 471K-T
C306	4610001830	S.TRI TZB4S100AB10R00 (TZB4N100BA110)
C307	4030009540	S.CER C1608 CH 1H 1R5B-T
C308	4030006880	S.CER C1608 JB 1H 472K-T
C321	4030006880	S.CER C1608 JB 1H 472K-T
C322	4030006880	S.CER C1608 JB 1H 472K-T
C325	4030006850	S.CER C1608 JB 1H 471K-T
C326	4030006880	S.CER C1608 JB 1H 472K-T
C331	4030007150	S.CER C1608 CH 1H 151J-T
C332	4030006850	S.CER C1608 JB 1H 471K-T
C333	4030008770	S.CER C1608 JB 1H 562K-T [ESP], [OTH], [ITA], [ITR], [OTH-1], [ITR-1], [CHN], [CHN-01] only
C334	4030009510	S.CER C1608 CH 1H 010B-T
C335	4610001830	S.TRI TZB4S100AB10R00 (TZB4N100BA110)
C336	4030006950	S.CER C1608 CH 1H 040C-T
C351	4030006880	S.CER C1608 JB 1H 472K-T
C352	4030006880	S.CER C1608 JB 1H 472K-T
C353	4030006880	S.CER C1608 JB 1H 472K-T except [FRA-1]
C355	4030006880	S.CER C1608 JB 1H 472K-T
C356	4030006850	S.CER C1608 JB 1H 471K-T
C364	4030006850	S.CER C1608 JB 1H 471K-T
C366	4030006970	S.CER C1608 CH 1H 060D-T
C367	4610001860	S.TRI TZB4Z060AB10R00 (TZB4Z060BA110)
C368	4030009510	S.CER C1608 CH 1H 010B-T
C369	4030006850	S.CER C1608 JB 1H 471K-T
C370	4030009570	S.CER C1608 CH 1H 0R3B-T
C372	4030006860	S.CER C1608 JB 1H 102K-T
C373	4510008500	S.ELE EEE1CA101WP
C374	4030011770	S.CER C1608 CH 1H 060B-T
C375	4030006860	S.CER C1608 JB 1H 102K-T
C376	4550002890	S.TAN TEESVA 1A 225M8R
C381	4030006880	S.CER C1608 JB 1H 472K-T
C382	4030006880	S.CER C1608 JB 1H 472K-T
C383	4030006880	S.CER C1608 JB 1H 472K-T except [FRA-1]
C385	4030006880	S.CER C1608 JB 1H 472K-T except [ESP]
C386	4030006880	S.CER C1608 JB 1H 472K-T except [EUR], [FRA], [ESP], [USA], [EUR-1], [ESP-1], [USA-1]
C391	4550006350	S.TAN TEESVB2 1A 226M8R
C392	4030006860	S.CER C1608 JB 1H 102K-T
C414	4550006250	S.TAN TEESVA 1A 106M8R
C444	4550000930	S.TAN TEESVA 1D 684M8R
C461	4550005980	S.TAN TEESVA 1A 475M8R
C463	4030006880	S.CER C1608 JB 1H 472K-T
C464	4550006080	S.TAN TEESVB2 1C 106M8R
C465	4030006900	S.CER C1608 JB 1H 103K-T
C466	4030006860	S.CER C1608 JB 1H 102K-T [OTH], [ITA], [ITR], [OTH-1], [ITA-1], [ITR-1], [CHN], [CHN-01] only
C467	4030011600	S.CER C1608 JB 1E 104K-T [OTH], [ITA], [ITR], [OTH-1], [ITA-1], [ITR-1], [CHN], [CHN-01] only
C468	4030011600	S.CER C1608 JB 1E 104K-T [OTH], [ITA], [ITR], [OTH-1], [ITA-1], [ITR-1], [CHN], [CHN-01] only
C472	4030006880	S.CER C1608 JB 1H 472K-T
C491	4030006860	S.CER C1608 JB 1H 102K-T
C492	4030006860	S.CER C1608 JB 1H 102K-T
C493	4030006860	S.CER C1608 JB 1H 102K-T
C501	4030006880	S.CER C1608 JB 1H 472K-T
C511	4030006880	S.CER C1608 JB 1H 472K-T
C512	4030006880	S.CER C1608 JB 1H 472K-T
C514	4030006880	S.CER C1608 JB 1H 472K-T
C521	4030006880	S.CER C1608 JB 1H 472K-T [ESP], [OTH], [ITA], [ITR], [OTH-1], [ITR-1], [CHN], [CHN-01] only
C531	4030006880	S.CER C1608 JB 1H 472K-T
C537	4030006880	S.CER C1608 JB 1H 472K-T
C541	4030006880	S.CER C1608 JB 1H 472K-T
C542	4030006880	S.CER C1608 JB 1H 472K-T
C543	4030006880	S.CER C1608 JB 1H 472K-T
C544	4030011340	S.CER C1608 CH 1H 471J-T except [EUR], [FRA], [USA]
C547	4030006880	S.CER C1608 JB 1H 472K-T
C600	4030011600	S.CER C1608 JB 1E 104K-T

S.=Surface mount

[PLL UNIT]

REF NO.	ORDER NO.	DESCRIPTION
C602	4030006880	S.CER C1608 JB 1H 472K-T
C603	4030006880	S.CER C1608 JB 1H 472K-T
C623	4030006880	S.CER C1608 JB 1H 472K-T
C624	4030008320	S.CER C1608 UJ 1H 470J-T
C625	4030006880	S.CER C1608 JB 1H 472K-T
C626	4030008320	S.CER C1608 UJ 1H 470J-T
C641	4030006980	S.CER C1608 CH 1H 070D-T
C642	4030009520	S.CER C1608 CH 1H 020B-T
C643	4030007030	S.CER C1608 CH 1H 150J-T
C644	4030009560	S.CER C1608 CH 1H R75B-T
C645	4030006990	S.CER C1608 CH 1H 080D-T
C662	4030006880	S.CER C1608 JB 1H 472K-T
C663	4030006880	S.CER C1608 JB 1H 472K-T
C664	4030007090	S.CER C1608 CH 1H 470J-T
C665	4030006880	S.CER C1608 JB 1H 472K-T
C681	4030006880	S.CER C1608 JB 1H 472K-T
C682	4030009650	S.CER C1608 CH 1H 240J-T
C683	4030006880	S.CER C1608 JB 1H 472K-T
C684	4030006920	S.CER C1608 CH 1H 010C-T
C685	4030009650	S.CER C1608 CH 1H 240J-T
C686	4030007090	S.CER C1608 CH 1H 470J-T
C701	4030006880	S.CER C1608 JB 1H 472K-T
C711	4030007070	S.CER C1608 CH 1H 330J-T
C712	4030007010	S.CER C1608 CH 1H 100D-T
C713	4030007090	S.CER C1608 CH 1H 470J-T
C714	4030006980	S.CER C1608 CH 1H 070D-T
C715	4030007060	S.CER C1608 CH 1H 270J-T
C731	4030006880	S.CER C1608 JB 1H 472K-T
C741	4030008560	S.CER C1608 CH 1H 300J-T
C742	4030007000	S.CER C1608 CH 1H 090D-T
C743	4030007070	S.CER C1608 CH 1H 330J-T
C744	4030006960	S.CER C1608 CH 1H 050C-T
C745	4030007040	S.CER C1608 CH 1H 180J-T
C761	4030006880	S.CER C1608 JB 1H 472K-T
C771	4030007020	S.CER C1608 CH 1H 120J-T
C772	4030007110	S.CER C1608 CH 1H 680J-T
C773	4030007030	S.CER C1608 CH 1H 150J-T
C781	4030007030	S.CER C1608 CH 1H 150J-T
C782	4030006940	S.CER C1608 CH 1H 030C-T
C783	4030007060	S.CER C1608 CH 1H 270J-T
C784	4030006990	S.CER C1608 CH 1H 080D-T
C785	4030007020	S.CER C1608 CH 1H 120J-T
C791	4030006880	S.CER C1608 JB 1H 472K-T
C801	4030007050	S.CER C1608 CH 1H 220J-T
C802	4030007060	S.CER C1608 CH 1H 270J-T
C803	4030007010	S.CER C1608 CH 1H 100D-T
C804	4030007120	S.CER C1608 CH 1H 820J-T
C805	4030007040	S.CER C1608 CH 1H 180J-T
C811	4030006990	S.CER C1608 CH 1H 080D-T
C812	4030006970	S.CER C1608 CH 1H 060D-T
C813	4030007040	S.CER C1608 CH 1H 180J-T
C814	4030006930	S.CER C1608 CH 1H 020C-T
C815	4030007010	S.CER C1608 CH 1H 100D-T
C821	4030007060	S.CER C1608 CH 1H 270J-T
C822	4030007020	S.CER C1608 CH 1H 120J-T
C823	4030007010	S.CER C1608 CH 1H 100D-T
C824	4030006990	S.CER C1608 CH 1H 080D-T
C825	4030007110	S.CER C1608 CH 1H 680J-T
C826	4030006860	S.CER C1608 JB 1H 102K-T
C827	4030007060	S.CER C1608 CH 1H 270J-T
C828	4030009910	S.CER C1608 CH 1H 040B-T
C829	4030007010	S.CER C1608 CH 1H 100D-T
C830	4030006980	S.CER C1608 CH 1H 070D-T
C831	4030007010	S.CER C1608 CH 1H 100D-T
C851	4030006880	S.CER C1608 JB 1H 472K-T
C852	4030006880	S.CER C1608 JB 1H 472K-T
C853	4030011340	S.CER C1608 CH 1H 471J-T except [EUR], [FRA], [USA]
C861	4030007030	S.CER C1608 CH 1H 150J-T
C862	4030007010	S.CER C1608 CH 1H 100D-T
C863	4030009920	S.CER C1608 CH 1H 050B-T
C864	4030006990	S.CER C1608 CH 1H 080D-T
C865	4030007090	S.CER C1608 CH 1H 470J-T
C871	4030007000	S.CER C1608 CH 1H 090D-T
C872	4030009500	S.CER C1608 CH 1H 0R5B-T
C873	4030009920	S.CER C1608 CH 1H 050B-T
C874	4030009540	S.CER C1608 CH 1H 1R5B-T
C875	4030009920	S.CER C1608 CH 1H 050B-T
C876	4030006880	S.CER C1608 JB 1H 472K-T
C881	4030007100	S.CER C1608 CH 1H 560J-T
C882	4030007110	S.CER C1608 CH 1H 680J-T
C883	4030007100	S.CER C1608 CH 1H 560J-T
C884	4030009910	S.CER C1608 CH 1H 040B-T
C885	4030009910	S.CER C1608 CH 1H 040B-T
C886	4030009910	S.CER C1608 CH 1H 040B-T
C902	4030011600	S.CER C1608 JB 1E 104K-T
C903	4030011600	S.CER C1608 JB 1E 104K-T
C904	4030011600	S.CER C1608 JB 1E 104K-T
C905	4030011600	S.CER C1608 JB 1E 104K-T
C906	4030011600	S.CER C1608 JB 1E 104K-T
C907	4030011600	S.CER C1608 JB 1E 104K-T
C931	4030011600	S.CER C1608 JB 1E 104K-T
C934	4030006880	S.CER C1608 JB 1H 472K-T
C935	4030006880	S.CER C1608 JB 1H 472K-T
C941	4030006880	S.CER C1608 JB 1H 472K-T
C942	4030011600	S.CER C1608 JB 1E 104K-T
C943	4030007050	S.CER C1608 CH 1H 220J-T
C945	4030007130	S.CER C1608 CH 1H 101J-T
C946	4030007140	S.CER C1608 CH 1H 121J-T

[PLL UNIT]

REF NO.	ORDER NO.	DESCRIPTION
C951	4030007010	S.CER C1608 CH 1H 100D-T
C981	4030007040	S.CER C1608 CH 1H 180J-T
C982	4030007090	S.CER C1608 CH 1H 470J-T
C983	4030007040	S.CER C1608 CH 1H 180J-T
C991	4030007040	S.CER C1608 CH 1H 180J-T
C992	4030006960	S.CER C1608 CH 1H 050C-T
C993	4030007070	S.CER C1608 CH 1H 330J-T
C994	4030006930	S.CER C1608 CH 1H 020C-T
C995	4030007040	S.CER C1608 CH 1H 180J-T
C1000	4030006860	S.CER C1608 JB 1H 102K-T
C1001	4030006860	S.CER C1608 JB 1H 102K-T
C1002	4030006860	S.CER C1608 JB 1H 102K-T
C1004	4030006860	S.CER C1608 JB 1H 102K-T
C1005	4030006860	S.CER C1608 JB 1H 102K-T
C1006	4030006860	S.CER C1608 JB 1H 102K-T
RL231	6330000621	RLY SY-12-K
CP281	6910009670	S.CHK HK3-S-T
CP282	6910009670	S.CHK HK3-S-T
J252	6510019981	S.CNR 52808-1671 (1690)
J253	6510019971	S.CNR 52808-1071
J254	6510019071	S.CNR 52559-3072 (3092)
W43	7030003860	S.RES ERJ3GE JPW V
W294	9034704001	WIR 72/98/005/X98/X98
W301	7030003860	S.RES ERJ3GE JPW V
W461	7030003860	S.RES ERJ3GE JPW V
W592	7030003860	S.RES ERJ3GE JPW V
W661	7030003860	S.RES ERJ3GE JPW V
W993	7030003860	S.RES ERJ3GE JPW V
EP2	6910012350	S.BEA MMZ1608Y 102BT

S.=Surface mount

[HPF BOARD]

REF NO.	ORDER NO.	DESCRIPTION
Q191	1560000721	S.FET 2SK2171-4-TD-E
Q211	1520000561	S.TR 2SB1123 T-TD-E
Q212	1590002310	S.TR DTC114EE TL
Q213	1590002310	S.TR DTC114EE TL
Q214	1590002480	S.TR UMC3N TR
Q215	1590002310	S.TR DTC114EE TL
D101	1790001260	S.DIO MA2S077-(TX)
D111	1790001260	S.DIO MA2S077-(TX)
D112	1790001260	S.DIO MA2S077-(TX)
D121	1790001260	S.DIO MA2S077-(TX)
D122	1790001260	S.DIO MA2S077-(TX)
D131	1790001260	S.DIO MA2S077-(TX)
D132	1790001260	S.DIO MA2S077-(TX)
D141	1790001260	S.DIO MA2S077-(TX)
D142	1790001260	S.DIO MA2S077-(TX)
D151	1790001260	S.DIO MA2S077-(TX)
D152	1790001260	S.DIO MA2S077-(TX)
D161	1790001260	S.DIO MA2S077-(TX)
D162	1790001260	S.DIO MA2S077-(TX)
D171	1790001260	S.DIO MA2S077-(TX)
D172	1790001260	S.DIO MA2S077-(TX)
D191	1790001260	S.DIO MA2S077-(TX)
D192	1790001260	S.DIO MA2S077-(TX)
D211	1750000520	S.DIO DAN222TL
D212	1750000520	S.DIO DAN222TL
L101	6200002911	S.COL NLV25T-R27J
L102	6200004961	S.COL NLV25T-R33J
L111	6200003241	S.COL NLV32T-221J
L121	6200002041	S.COL NLV25T-101J
L122	6200007170	S.COL MLF1608A 3R3K-T
L123	6200003550	S.COL MLF1608A 4R7K-T
L124	6200002041	S.COL NLV25T-101J
L131	6200004920	S.COL MLF1608A 2R2K-T
L132	6200004660	S.COL MLF1608A 1R8K-T
L133	6200004660	S.COL MLF1608A 1R8K-T
L134	6200002041	S.COL NLV25T-101J
L141	6200003960	S.COL MLF1608A 1R0K-T
L142	6200003960	S.COL MLF1608A 1R0K-T
L143	6200003960	S.COL MLF1608A 1R0K-T
L144	6200002041	S.COL NLV25T-101J
L151	6200002041	S.COL NLV25T-101J
L152	6200001700	S.COL MLF2012D R47K-T
L153	6200001200	S.COL MLF2012D R56M-T
L154	6200001210	S.COL MLF2012D R68M-T
L155	6200001060	S.COL MLF2012D 47NM-T
L161	6200002041	S.COL NLV25T-101J
L162	6200001170	S.COL MLF2012D R33M-T
L163	6200001180	S.COL MLF2012D R39K-T
L164	6200002041	S.COL NLV25T-101J
L171	6200005011	S.COL NLV25T-100J
L172	6200001090	S.COL MLF2012D 68NM-T
L173	6200001100	S.COL MLF2012D 82NM-T
L174	6200001870	S.COL MLF2012D R27K-T
L175	6200001130	S.COL MLF2012D R15M-T
L176	6200005011	S.COL NLV25T-100J
L191	6200005011	S.COL NLV25T-100J
L192	6200003840	S.COL MLF2012D R22K-T
L193	6200001170	S.COL MLF2012D R33M-T
L194	6200003281	S.COL NLV25T-2R2J
L195	6140002810	S.COL LR-317 (
L196	6200001500	S.COL MLF2012D R12K-T
L197	6200004150	S.COL MLF1608D 47NM-T
R101	7030003760	S.RES ERJ3GEYJ 474 V (470 k)
R102	7030003760	S.RES ERJ3GEYJ 474 V (470 k)
R111	7030003320	S.RES ERJ3GEYJ 101 V (100)
R171	7030003720	S.RES ERJ3GEYJ 224 V (220 k)
R172	7030003320	S.RES ERJ3GEYJ 101 V (100)
R191	7030003720	S.RES ERJ3GEYJ 224 V (220 k)
R192	7030003280	S.RES ERJ3GEYJ 470 V (47)
R193	7030003340	S.RES ERJ3GEYJ 151 V (150)
R194	7030004050	S.RES ERJ3GEYJ 1R0 V (1)
R195	7030003280	S.RES ERJ3GEYJ 470 V (47)
R211	7030003560	S.RES ERJ3GEYJ 103 V (10 k)
R212	7030003520	S.RES ERJ3GEYJ 472 V (4.7 k)
R213	7030003560	S.RES ERJ3GEYJ 103 V (10 k)
R214	7030003560	S.RES ERJ3GEYJ 103 V (10 k)
C101	4030007110	S.CER C1608 CH 1H 680J-T
C102	4030007060	S.CER C1608 CH 1H 270J-T
C103	4030007150	S.CER C1608 CH 1H 151J-T
C104	4030007010	S.CER C1608 CH 1H 100D-T
C105	4030007120	S.CER C1608 CH 1H 820J-T
C111	4030010210	S.CER C3216 JB 1C 105M-T
C121	4030011600	S.CER C1608 JB 1E 104K-T
C122	4030008470	S.CER C1608 JB 1H 272K-T
C123	4030008860	S.CER C1608 JB 1H 153K-T
C124	4030009980	S.CER C1608 JB 1H 152K-T
C125	4030011600	S.CER C1608 JB 1E 104K-T
C126	4030006880	S.CER C1608 JB 1H 472K-T
C131	4030011600	S.CER C1608 JB 1E 104K-T
C132	4030009580	S.CER C1608 JB 1H 681K-T
C133	4030009980	S.CER C1608 JB 1H 152K-T
C134	4030009580	S.CER C1608 JB 1H 681K-T
C135	4030008470	S.CER C1608 JB 1H 272K-T
C136	4030006860	S.CER C1608 JB 1H 102K-T
C141	4030011600	S.CER C1608 JB 1E 104K-T
C142	4030010240	S.CER C1608 JB 1H 391K-T

[HPF BOARD]

REF NO.	ORDER NO.	DESCRIPTION
C143	4030010030	S.CER C1608 SL 1H 511J-T
C144	4030010760	S.CER C1608 CH 1H 331J-T
C145	4030006860	S.CER C1608 JB 1H 102K-T
C146	4030009580	S.CER C1608 JB 1H 681K-T
C147	4030011600	S.CER C1608 JB 1E 104K-T
C151	4030011600	S.CER C1608 JB 1E 104K-T
C152	4030007160	S.CER C1608 CH 1H 181J-T
C153	4030006860	S.CER C1608 JB 1H 102K-T
C154	4030007150	S.CER C1608 CH 1H 151J-T
C155	4030011330	S.CER C1608 CH 1H 391J-T
C156	4030007170	S.CER C1608 CH 1H 221J-T
C161	4030011600	S.CER C1608 JB 1E 104K-T
C162	4030007170	S.CER C1608 CH 1H 221J-T
C163	4030010020	S.CER C1608 JB 1H 122K-T
C164	4030007130	S.CER C1608 CH 1H 101J-T
C165	4030010760	S.CER C1608 CH 1H 331J-T
C166	4030006880	S.CER C1608 JB 1H 472K-T
C171	4030006900	S.CER C1608 JB 1H 103K-T
C172	4030007080	S.CER C1608 CH 1H 390J-T
C173	4030011540	S.CER C1608 CH 1H 750J-T
C174	4030007150	S.CER C1608 CH 1H 151J-T
C175	4030009650	S.CER C1608 CH 1H 240J-T
C176	4030007150	S.CER C1608 CH 1H 151J-T
C177	4030007140	S.CER C1608 CH 1H 121J-T
C178	4030007110	S.CER C1608 CH 1H 680J-T
C179	4030007090	S.CER C1608 CH 1H 470J-T
C180	4030010760	S.CER C1608 CH 1H 331J-T
C181	4030007120	S.CER C1608 CH 1H 820J-T
C182	4030006900	S.CER C1608 JB 1H 103K-T
C191	4030006880	S.CER C1608 JB 1H 472K-T
C192	4030006900	S.CER C1608 JB 1H 103K-T
C193	4030007100	S.CER C1608 CH 1H 560J-T
C194	4030007160	S.CER C1608 CH 1H 181J-T
C195	4030007070	S.CER C1608 CH 1H 330J-T
C196	4030006900	S.CER C1608 JB 1H 103K-T
C197	4030006900	S.CER C1608 JB 1H 103K-T
C198	4030007080	S.CER C1608 CH 1H 390J-T
C199	4030007030	S.CER C1608 CH 1H 150J-T
C200	4030007080	S.CER C1608 CH 1H 390J-T
J101	6510021270	S.CNR AXK5S20045P

[PA UNIT]

REF NO.	ORDER NO.	DESCRIPTION
Q101	1560001091	S.FET 2SK2854 (T2LICOM,F)
Q121	1560001101	S.FET 2SK3074 (TE12L,F)
Q171	1560001191	FET RD70HVF1-121
Q172	1560001191	FET RD70HVF1-121
Q231	1560001191	FET RD70HVF1-121
Q301	1590000680	S.TR DTC114EUA T106
Q351	1590000680	S.TR DTC114EUA T106
Q352	1590000680	S.TR DTC114EUA T106
Q402	1590000680	S.TR DTC114EUA T106
Q403	1580000691	S.FET 3SK291 (TE85R,F)
Q452	1590000680	S.TR DTC114EUA T106
Q453	1580000691	S.FET 3SK291 (TE85R,F)
Q501	1520000460	S.TR 2SB1132 T100 R
Q502	1590000680	S.TR DTC114EUA T106
Q511	1510000920	S.TR 2SA1577 T106 Q
Q512	1590000680	S.TR DTC114EUA T106
Q513	1590000680	S.TR DTC114EUA T106
Q514	1590000680	S.TR DTC114EUA T106
Q521	1520000460	S.TR 2SB1132 T100 R
Q522	1590000680	S.TR DTC114EUA T106
Q523	1590000680	S.TR DTC114EUA T106
Q531	1510000920	S.TR 2SA1577 T106 Q
Q532	1590000680	S.TR DTC114EUA T106
Q533	1590000680	S.TR DTC114EUA T106
Q541	1590001330	S.TR DTA114EUA T106
Q542	1590000680	S.TR DTC114EUA T106
Q551	1590001330	S.TR DTA114EUA T106
Q552	1590000680	S.TR DTC114EUA T106
Q571	1520000460	S.TR 2SB1132 T100 R
Q572	1530002060	S.TR 2SC4081 T106 R
Q573	1590001330	S.TR DTA114EUA T106
Q574	1530002060	S.TR 2SC4081 T106 R
Q575	1590000680	S.TR DTC114EUA T106
Q576	1590001330	S.TR DTA114EUA T106
Q591	1590000680	S.TR DTC114EUA T106
D101	1790000620	S.DIO MA77 (TX)
D102	1790000620	S.DIO MA77 (TX)
D103	1790000620	S.DIO MA77 (TX)
D104	1790000620	S.DIO MA77 (TX)
D171	1160000060	S.DIO DAN202U T106
D172	1160000060	S.DIO DAN202U T106
D173	1750000590	S.DIO DAN217T146
D174	1750000590	S.DIO DAN217T146
D175	1750000590	S.DIO DAN217T146
D176	1750000590	S.DIO DAN217T146
D231	1160000060	S.DIO DAN202U T106
D261	1710001061	DIO L407CDB
D262	1790000980	S.DIO MA742 (TX)
D263	1790000980	S.DIO MA742 (TX)
D291	1750000511	S.DIO UX9401F-STD/TR
D292	1750000511	S.DIO UX9401F-STD/TR

S.=Surface mount



[PA UNIT]

REF NO.	ORDER NO.	DESCRIPTION
D293	1750000550	S.DIO 1SS355 TE-17
D301	1750000511	S.DIO UX9401F-STD/TR
D311	1750000511	S.DIO UX9401F-STD/TR
D312	1790001240	S.DIO MA2S728-(TX)
D313	1790001240	S.DIO MA2S728-(TX)
D341	1750000511	S.DIO UX9401F-STD/TR
D342	1750000511	S.DIO UX9401F-STD/TR
D343	1790001621	S.DIO 1SV308 (TPL3,F)
D344	1710001061	DIO L407CDB
D352	1750000550	S.DIO 1SS355 TE-17
D401	1790001621	S.DIO 1SV308 (TPL3,F)
D402	1790001621	S.DIO 1SV308 (TPL3,F)
D403	1750000610	S.VCP MA2SV0500L
D404	1790001621	S.DIO 1SV308 (TPL3,F)
D405	1790001621	S.DIO 1SV308 (TPL3,F)
D406	1750000610	S.VCP MA2SV0500L
D407	1720000590	S.VCP MA357 (TX)
D408	1720000590	S.VCP MA357 (TX)
D409	1750000610	S.VCP MA2SV0500L
D410	1750000610	S.VCP MA2SV0500L
D411	1720000261	S.VCP 1SV214 (TPH2,F)
D451	1790001621	S.DIO 1SV308 (TPL3,F)
D452	1790001621	S.DIO 1SV308 (TPL3,F)
D453	1720000701	S.VCP 1SV305 (TPL3,F)
D454	1720000701	S.VCP 1SV305 (TPL3,F)
D455	1720000701	S.VCP 1SV305 (TPL3,F)
D456	1720000701	S.VCP 1SV305 (TPL3,F)
D481	1750000211	S.DIO 1SV237 (TE85R,F)
D573	1160000060	S.DIO DAN202U T106
D574	1790000950	S.ZEN MA8056-M (TX)
D575	1160000060	S.DIO DAN202U T106
D591	1160000060	S.DIO DAN202U T106
D601	1790000700	DIO DSA3A1
D602	1790000700	DIO DSA3A1
L102	6200005051	S.COL NLV25T-330J
L103	6200008570	S.COL LQW2BHN6N8D03L
L104	6200005731	S.COL ELJRE 39NGFA
L105	6200002861	S.COL NLV25T-4R7J
L106	6200002041	S.COL NLV25T-101J
L121	6180000870	COL LAL 03NA 6R8K
L122	6200003950	S.COL HF50ACC 322513-T
L123	6180000900	COL LAL 03NA 101K
L141	6200008080	S.COL LQW2BHN22J03L
L142	6200007800	S.COL LQW2BHN18J03L
L143	6200007790	S.COL LQW2BHN15J03L
L152	6200007740	S.COL LQW2BHN47N03L
L161	2040000490	COL EXC-ELDR25C
L162	6140002220	COL LR-270 (TR6X3X2 3A9)
L171	6140003040	COL LR-322B
L172	6140000610	COL LR-83
L173	6140003350	COL LR-376
L173	6140003380	COL LR-379
L174	6140002030	COL LR-230 (SK-10M-15Y 120)
L175	6110001730	COL LA-262
L211	2040000490	COL EXC-ELDR25C
L212	2040000490	COL EXC-ELDR25C
L232	6110003560	COL LA-549
L233	2040000490	COL EXC-ELDR25C
L234	2040000490	COL EXC-ELDR25C
L261	6170000230	COL LW-25
L262	6110001670	COL LA-253
L263	6110001670	COL LA-253
L264	6110001680	COL LA-254
L265	6110001600	COL LA-243
L291	6110001540	COL LA-234
L292	6110001540	COL LA-234
L301	6200013000	S.COL 0.25-1.9-13TL 135N <COMO>
L311	6170000230	COL LW-25
L312	6110002110	COL LA-382
L313	6110002130	COL LA-383
L314	6110001520	COL LA-232
L315	6110002110	COL LA-382
L316	6110002110	COL LA-382
L317	6110002110	COL LA-382
L341	6110001520	COL LA-232
L342	6110001520	COL LA-232
L351	6200013000	S.COL 0.25-1.9-13TL 135N <COMO>
L352	6170000230	COL LW-25
L361	6170000230	COL LW-25
L401	6200007710	S.COL LQW2BHN27N03L
L401	6200007720	S.COL LQW2BHN33N03L
L402	6200007760	S.COL LQW2BHN82N03L
L403	6200003711	S.COL NLV25T-2R7J
L404	6200003640	S.COL MLF1608E 100K-T
L406	6200007700	S.COL LQW2BHN22N03L
L407	6200007760	S.COL LQW2BHN82N03L
L408	6200007710	S.COL LQW2BHN27N03L
L409	6200007740	S.COL LQW2BHN47N03L
L410	6200003640	S.COL MLF1608E 100K-T
L453	6200012660	S.COL 0.30-1.0-4TR 9.1N <COMO>
L455	6200007230	S.COL LQW2BHN15N03L
L456	6200005621	S.COL ELJRE 4N7ZFA
L461	6200007680	S.COL LQW2BHN12N03L
L571	6200003950	S.COL HF50ACC 322513-T
L611	6200003241	S.COL NLV32T-221J
L612	6200003241	S.COL NLV32T-221J
L613	6910003570	COL 2943-666663
L614	6910003570	COL 2943-666663
L621	6200003950	S.COL HF50ACC 322513-T
L622	6200003550	S.COL MLF1608A 4R7K-T
L623	6200003550	S.COL MLF1608A 4R7K-T

[PA UNIT]

REF NO.	ORDER NO.	DESCRIPTION
L663	6200004480	S.COL MLF1608D R82K-T
L664	2040000490	COL EXC-ELDR25C
L665	2040000490	COL EXC-ELDR25C
R102	7030003220	S.RES ERJ3GEYJ 150 V (15)
R104	7030003300	S.RES ERJ3GEYJ 680 V (68)
R105	7030003520	S.RES ERJ3GEYJ 472 V (4.7 k)
R106	7030003520	S.RES ERJ3GEYJ 472 V (4.7 k)
R107	7030003420	S.RES ERJ3GEYJ 681 V (680)
R108	7030008190	S.RES ERJ12YJ330U (33)
R111	7030003400	S.RES ERJ3GEYJ 471 V (470)
R112	7030003380	S.RES ERJ3GEYJ 331 V (330)
R113	7030003380	S.RES ERJ3GEYJ 331 V (330)
R114	7030003380	S.RES ERJ3GEYJ 331 V (330)
R115	7030003440	S.RES ERJ3GEYJ 102 V (1 k)
R121	7030000230	S.RES MCR10EZHZH 56 (560)
R122	7030003520	S.RES ERJ3GEYJ 472 V (4.7 k)
R123	7030003520	S.RES ERJ3GEYJ 472 V (4.7 k)
R124	7030003410	S.RES ERJ3GEYJ 561 V (560)
R125	7030009570	S.RES ERJ1WYJ5R6U (5.6)
R126	7030000340	S.RES MCR10EZHZH 470 (471)
R127	7030000140	S.RES MCR10EZHZH 10 (100)
R161	7030000260	S.RES MCR10EZHZH 100 (101)
R162	7310005240	TRI VM5CK-PVB 5 k
R163	7030003440	S.RES ERJ3GEYJ 102 V (1 k)
R164	7030003440	S.RES ERJ3GEYJ 102 V (1 k)
R172	7030006080	S.RES ERJ1WYJ220U (22)
R173	7030006080	S.RES ERJ1WYJ220U (22)
R174	7310005230	TRI VM5CK-PVB 10 k
R175	7310005230	TRI VM5CK-PVB 10 k
R176	7030003480	S.RES ERJ3GEYJ 222 V (2.2 k)
R177	7030003480	S.RES ERJ3GEYJ 222 V (2.2 k)
R178	7030007130	S.RES ERJ1WYJ150U (15)
R179	7030007130	S.RES ERJ1WYJ150U (15)
R180	7030006130	S.RES ERJ1WYJ100U (10)
R181	7030006130	S.RES ERJ1WYJ100U (10)
R182	7030007630	S.RES MCR100JZHJ 0.68 (R68)
R183	7030007630	S.RES MCR100JZHJ 0.68 (R68)
R185	7030010950	S.RES ERJ1TYJ 100U (10)
R186	7030010950	S.RES ERJ1TYJ 100U (10)
R201	7100000810	S.RES ERX5WQK 12MH
R202	7030003500	S.RES ERJ3GEYJ 332 V (3.3 k)
R203	7030003500	S.RES ERJ3GEYJ 332 V (3.3 k)
R204	7030003500	S.RES ERJ3GEYJ 332 V (3.3 k)
R205	7030003500	S.RES ERJ3GEYJ 332 V (3.3 k)
R211	7030000340	S.RES MCR10EZHZH 470 (471)
R213	7030003440	S.RES ERJ3GEYJ 102 V (1 k)
R214	7310005240	TRI VM5CK-PVB 5 k
R215	7030003460	S.RES ERJ3GEYJ 152 V (1.5 k)
R231	7310005230	TRI VM5CK-PVB 10 k
R232	7030000340	S.RES MCR10EZHZH 470 (471)
R234	7030003430	S.RES ERJ3GEYJ 821 V (820)
R235	7030003430	S.RES ERJ3GEYJ 821 V (820)
R236	7310005140	S.TRI RH03ADCJ3X (2.2 k)
R237	7030003480	S.RES ERJ3GEYJ 222 V (2.2 k)
R261	7030007360	S.RES ERJ1WYJ470U (47)
R262	7030003680	S.RES ERJ3GEYJ 104 V (100 k)
R263	7030003440	S.RES ERJ3GEYJ 102 V (1 k)
R264	7030003440	S.RES ERJ3GEYJ 102 V (1 k)
R266	7030003560	S.RES ERJ3GEYJ 103 V (10 k)
R267	7030003440	S.RES ERJ3GEYJ 102 V (1 k)
R268	7030003560	S.RES ERJ3GEYJ 103 V (10 k)
R269	7030003440	S.RES ERJ3GEYJ 102 V (1 k)
R301	7030003560	S.RES ERJ3GEYJ 103 V (10 k)
R302	7030006070	S.RES ERJ12YJ101U (100)
R303	7030000340	S.RES MCR10EZHZH 470 (471)
R311	7030007360	S.RES ERJ1WYJ470U (47)
R312	7030003680	S.RES ERJ3GEYJ 104 V (100 k)
R313	7030003440	S.RES ERJ3GEYJ 102 V (1 k)
R314	7030003440	S.RES ERJ3GEYJ 102 V (1 k)
R317	7030003550	S.RES ERJ3GEYJ 822 V (8.2 k)
R319	7030003550	S.RES ERJ3GEYJ 822 V (8.2 k)
R320	7030003520	S.RES ERJ3GEYJ 472 V (4.7 k)
R342	7030003560	S.RES ERJ3GEYJ 103 V (10 k)
R351	7030003560	S.RES ERJ3GEYJ 103 V (10 k)
R352	7030006180	S.RES ERJ1WYJ101U (100)
R361	7030003640	S.RES ERJ3GEYJ 473 V (47 k)
R403	7030003470	S.RES ERJ3GEYJ 182 V (1.8 k)
R407	7030004040	S.RES ERJ3GEYJ 4R7 V (4.7)
R408	7030003260	S.RES ERJ3GEYJ 330 V (33)
R409	7030003680	S.RES ERJ3GEYJ 104 V (100 k)
R410	7030003440	S.RES ERJ3GEYJ 102 V (1 k)
R411	7030003740	S.RES ERJ3GEYJ 334 V (330 k)
R412	7030003710	S.RES ERJ3GEYJ 184 V (180 k)
R413	7030003720	S.RES ERJ3GEYJ 224 V (220 k)
R414	7030003740	S.RES ERJ3GEYJ 334 V (330 k)
R415	7030003330	S.RES ERJ3GEYJ 121 V (120)
R416	7030003330	S.RES ERJ3GEYJ 121 V (120)
R417	7030003680	S.RES ERJ3GEYJ 104 V (100 k)
R418	7030003440	S.RES ERJ3GEYJ 102 V (1 k)
R419	7030003680	S.RES ERJ3GEYJ 104 V (100 k)
R420	7030003680	S.RES ERJ3GEYJ 104 V (100 k)
R421	7030003680	S.RES ERJ3GEYJ 104 V (100 k)
R422	7030003380	S.RES ERJ3GEYJ 331 V (330)
R423	7030003720	S.RES ERJ3GEYJ 224 V (220 k)
R424	7030003420	S.RES ERJ3GEYJ 681 V (680)
R451	7030003470	S.RES ERJ3GEYJ 182 V (1.8 k)
R452	7030004040	S.RES ERJ3GEYJ 4R7 V (4.7)
R453	7030004040	S.RES ERJ3GEYJ 4R7 V (4.7)
R455	7030003460	S.RES ERJ3GEYJ 152 V (1.5 k)

[ITA-1]  
except [ITA-1]  
[ITA-1]  
except [ITA-1]

S.=Surface mount

[PA UNIT]

REF NO.	ORDER NO.	DESCRIPTION
R459	7030003680	S.RES ERJ3GEYJ 104 V (100 k)
R460	7030003700	S.RES ERJ3GEYJ 154 V (150 k)
R461	7030003740	S.RES ERJ3GEYJ 334 V (330 k)
R462	7030003740	S.RES ERJ3GEYJ 334 V (330 k)
R463	7030003270	S.RES ERJ3GEYJ 390 V (39)
R464	7030003680	S.RES ERJ3GEYJ 104 V (100 k)
R465	7030003210	S.RES ERJ3GEYJ 120 V (12)
R468	7030003380	S.RES ERJ3GEYJ 331 V (330)
R469	7030003750	S.RES ERJ3GEYJ 394 V (390 k)
R470	7030003680	S.RES ERJ3GEYJ 104 V (100 k)
R471	7030003730	S.RES ERJ3GEYJ 274 V (270 k)
R501	7030003640	S.RES ERJ3GEYJ 473 V (47 k)
R502	7030003440	S.RES ERJ3GEYJ 102 V (1 k)
R511	7030003640	S.RES ERJ3GEYJ 473 V (47 k)
R512	7030003440	S.RES ERJ3GEYJ 102 V (1 k)
R513	7030003560	S.RES ERJ3GEYJ 103 V (10 k)
R521	7030003640	S.RES ERJ3GEYJ 473 V (47 k)
R522	7030003440	S.RES ERJ3GEYJ 102 V (1 k)
R531	7030003640	S.RES ERJ3GEYJ 473 V (47 k)
R532	7030003440	S.RES ERJ3GEYJ 102 V (1 k)
R571	7510001470	S.TMR NTCG20 4AG 473JT
R572	7510001470	S.TMR NTCG20 4AG 473JT
R575	7030003450	S.RES ERJ3GEYJ 122 V (1.2 k)
R576	7030003560	S.RES ERJ3GEYJ 103 V (10 k)
R577	7030003440	S.RES ERJ3GEYJ 102 V (1 k)
R579	7030003670	S.RES ERJ3GEYJ 823 V (82 k)
R580	7030003660	S.RES ERJ3GEYJ 683 V (68 k)
R581	7030003460	S.RES ERJ3GEYJ 152 V (1.5 k)
R582	7510001470	S.TMR NTCG20 4AG 473JT
R591	7030004040	S.RES ERJ3GEYJ 4R7 V (4.7)
C101	4030009530	S.CER C1608 CH 1H 030B-T
C102	4030011600	S.CER C1608 JB 1E 104K-T
C103	4510004591	ELE 16 ME 470 HC
C104	4030011600	S.CER C1608 JB 1E 104K-T
C106	4030011600	S.CER C1608 JB 1E 104K-T
C109	4030011600	S.CER C1608 JB 1E 104K-T
C111	4030011600	S.CER C1608 JB 1E 104K-T
C113	4030011600	S.CER C1608 JB 1E 104K-T
C114	4030007080	S.CER C1608 CH 1H 390J-T
C115	4030006980	S.CER C1608 CH 1H 070D-T
C116	4030007080	S.CER C1608 CH 1H 390J-T
C117	4030011600	S.CER C1608 JB 1E 104K-T
C118	4030011600	S.CER C1608 JB 1E 104K-T
C121	4030011600	S.CER C1608 JB 1E 104K-T
C123	4030011600	S.CER C1608 JB 1E 104K-T
C125	4030011600	S.CER C1608 JB 1E 104K-T
C126	4030004710	S.CER C2012 JB 1H 471K-T
C127	4030011600	S.CER C1608 JB 1E 104K-T
C128	4030008960	S.CER C2012 JB 1C 104K-T
C129	4030011600	S.CER C1608 JB 1E 104K-T
C141	4030008960	S.CER C2012 JB 1C 104K-T
C144	4030007110	S.CER C1608 CH 1H 680J-T
C145	4030006970	S.CER C1608 CH 1H 060D-T
C146	4030007110	S.CER C1608 CH 1H 680J-T
C147	4030009530	S.CER C1608 CH 1H 030B-T
C148	4030007080	S.CER C1608 CH 1H 390J-T
C151	4030007040	S.CER C1608 CH 1H 180J-T
C152	4030010240	S.CER C1608 JB 1H 391K-T
C153	4030007030	S.CER C1608 CH 1H 150J-T
C155	4030007090	S.CER C1608 CH 1H 470J-T
C156	4030009910	S.CER C1608 CH 1H 040B-T
C161	4030008960	S.CER C2012 JB 1C 104K-T
C163	4030011600	S.CER C1608 JB 1E 104K-T
C165	4030011600	S.CER C1608 JB 1E 104K-T
C167	4030008960	S.CER C2012 JB 1C 104K-T
C169	4510004591	ELE 16 ME 470 HC
C170	4010005930	CER HM11SJ SL 391J 500V
C172	4030011760	S.CER GRM55R1X2D682JV01L (GRM44-1)
C173	4030011760	S.CER GRM55R1X2D682JV01L (GRM44-1)
C174	4030011600	S.CER C1608 JB 1E 104K-T
C175	4030011600	S.CER C1608 JB 1E 104K-T
C176	4030011600	S.CER C1608 JB 1E 104K-T
C178	4030011760	S.CER GRM55R1X2D682JV01L (GRM44-1)
C179	4030011760	S.CER GRM55R1X2D682JV01L (GRM44-1)
C182	4030011730	S.CER GRM31M2C2H101JV01L (GRM42-6 CH)
C183	4030011740	S.CER GRM32N2C2H201JV01L (GRM42-2 CH)
C186	4320001050	S.MIC UC342H 3900J-T
C187	4030011790	S.CER GRM55RF52A684ZD01L (GRM44-1)
C188	4510004601	ELE 16 ME 1000 HC
C189	4030008960	S.CER C2012 JB 1C 104K-T
C190	4320001120	S.MIC UC342H2200J-T 220P
C191	4030011740	S.CER GRM32N2C2H201JV01L (GRM42-2 CH)
C193	4030006850	S.CER C1608 JB 1H 471K-T
C195	4030011160	S.CER GRM31M2C2H150JV01L (GRM42-6 CH)
C196	4030006860	S.CER C1608 JB 1H 102K-T
C197	4030006860	S.CER C1608 JB 1H 102K-T
C198	4030006860	S.CER C1608 JB 1H 102K-T
C199	4030006860	S.CER C1608 JB 1H 102K-T
C200	4030006860	S.CER C1608 JB 1H 102K-T
C201	4030011600	S.CER C1608 JB 1E 104K-T
C202	4030011600	S.CER C1608 JB 1E 104K-T
C207	4510004601	ELE 16 ME 1000 HC
C212	4030004830	S.CER C2012 CH 1H 060D-T
C213	4030004720	S.CER C2012 JB 1H 102K-T
C214	4030004720	S.CER C2012 JB 1H 102K-T
C216	4510008540	S.ELE EEE1CA100SR
C217	4030004740	S.CER C2012 JB 1H 472K-T
C218	4030004570	S.CER C2012 SL 1H 470J-T except [ESP], [OTH], [ITA], [ITR], [ESP-1], [OTH-1]
C219	4030006880	S.CER C1608 JB 1H 472K-T
C220	4030011190	S.CER GRM31M2C2H270JV01L (GRM42-6 CH)

[PA UNIT]

REF NO.	ORDER NO.	DESCRIPTION
C231	4030011740	S.CER GRM32N2C2H201JV01L (GRM42-2 CH) [ESP], [OTH], [CHN], [CHN-01] only
C232	4030006880	S.CER C1608 JB 1H 472K-T
C233	4030006860	S.CER C1608 JB 1H 102K-T
C235	4030011160	S.CER GRM31M2C2H150JV01L (GRM42-6 CH)
C236	4030011210	S.CER GRM31M2C2H330JV01L (GRM42-6 CH)
C237	4030004570	S.CER C2012 SL 1H 470J-T except [ESP], [OTH], [ITA], [ITR], [ESP-1], [OTH-1]
C238	4030004740	S.CER C2012 JB 1H 472K-T
C239	4030006880	S.CER C1608 JB 1H 472K-T
C240	4030018050	S.CER ERF22X 6C2H 270J D01L
C241	4030017960	S.CER ERF22X 6C2H 330J D01L
C242	4030017980	S.CER ERF22X 6C2H 470J D01L
C243	4030018290	S.CER ERF22X 6C2H 390J D01L
C244	4030018050	S.CER ERF22X 6C2H 270J D01L
C245	4030018040	S.CER ERF22X 6C2H 180J D01L
C246	4030017200	S.CER GRM31BR32J102KY01L (GHM1030 R) [ESP], [OTH], [ITA], [ITR], [OTH-1], [ITR-1], [CHN], [CHN-01] only
C247	4030006850	S.CER C1608 JB 1H 471K-T
C248	4030011120	S.CER GRM31M2C2H100JV01L (GRM42-6 CH)
C250	4030006860	S.CER C1608 JB 1H 102K-T
C251	4030004720	S.CER C2012 JB 1H 102K-T
C261	4030018260	S.CER ERF22X 6C2H 150J D01L
C262	4030006860	S.CER C1608 JB 1H 102K-T
C264	4030011210	S.CER GRM31M2C2H330JV01L (GRM42-6 CH)
C265	4030017200	S.CER GRM31BR32J102KY01L (GHM1030 R) [ESP], [OTH], [ITA], [ITR], [OTH-1], [ITR-1], [CHN], [CHN-01] only
C268	4030006860	S.CER C1608 JB 1H 102K-T
C272	4030006860	S.CER C1608 JB 1H 102K-T
C274	4030011190	S.CER GRM31M2C2H270JV01L (GRM42-6 CH)
C275	4030011160	S.CER GRM31M2C2H150JV01L (GRM42-6 CH)
C276	4030011190	S.CER GRM31M2C2H270JV01L (GRM42-6 CH)
C278	4030006860	S.CER C1608 JB 1H 102K-T
C279	4030006860	S.CER C1608 JB 1H 102K-T
C280	4030006850	S.CER C1608 JB 1H 471K-T
C281	4030006860	S.CER C1608 JB 1H 102K-T
C282	4030011110	S.CER GRM31M2C2H90RDV01L (GRM42-6 CH)
C283	4030011120	S.CER GRM31M2C2H100JV01L (GRM42-6 CH)
C291	4030008560	S.CER C1608 CH 1H 300J-T
C292	4030009920	S.CER C1608 CH 1H 050B-T
C301	4030011190	S.CER GRM31M2C2H270JV01L (GRM42-6 CH)
C302	4030006860	S.CER C1608 JB 1H 102K-T
C303	4030006860	S.CER C1608 JB 1H 102K-T
C311	4030011210	S.CER GRM31M2C2H330JV01L (GRM42-6 CH)
C312	4030006860	S.CER C1608 JB 1H 102K-T
C313	4030004890	S.CER C2012 CH 1H 150J-T
C314	4030004890	S.CER C2012 CH 1H 150J-T
C317	4030006860	S.CER C1608 JB 1H 102K-T
C318	4030004780	S.CER C2012 CH 1H 010C-T
C319	4030004780	S.CER C2012 CH 1H 010C-T
C321	4030006860	S.CER C1608 JB 1H 102K-T
C322	4030011080	S.CER GRM31M2C2H6R0DV01L (GRM42-6 CH)
C323	4030011090	S.CER GRM31M2C2H7R0DV01L (GRM42-6 CH)
C324	4030011140	S.CER GRM31M2C2H120JV01L (GRM42-6 CH)
C325	4030011070	S.CER GRM31M2C2H5R0CY21L (GRM42-6 CH)
C326	4030011090	S.CER GRM31M2C2H7R0DV01L (GRM42-6 CH)
C327	4030011070	S.CER GRM31M2C2H5R0CY21L (GRM42-6 CH)
C328	4030011100	S.CER GRM31M2C2H8R0DV01L (GRM42-6 CH)
C329	4030006860	S.CER C1608 JB 1H 102K-T
C331	4030011040	S.CER GRM31M4C2H2R0CY21L (GRM42-6 CK) [ESP], [ITR] only
C332	4030011120	S.CER GRM31M2C2H100JV01L (GRM42-6 CH) [EUR], [FRA], [ESP], [USA] [ITR] only
C333	4030011040	S.CER GRM31M4C2H2R0CY21L (GRM42-6 CK)
C341	4030007020	S.CER C1608 CH 1H 120J-T
C342	4030017200	S.CER GRM31BR32J102KY01L (GHM1030 R)
C344	4030011040	S.CER GRM31M4C2H2R0CY21L (GRM42-6 CK) [ESP], [ITA], [ITR] only
C345	4030011050	S.CER GRM31M3C2H3R0CY21L (GRM42-6 CJ) [OTH], [OTH-1], [CHN], [CHN-01] only
C345	4030017200	S.CER GRM31BR32J102KY01L (GHM1030 R) [ESP], [OTH], [ITA], [ITR], [OTH-1], [ITR-1], [CHN], [CHN-01] only
C353	4030006860	S.CER C1608 JB 1H 102K-T
C354	4030006860	S.CER C1608 JB 1H 102K-T
C361	4030006880	S.CER C1608 JB 1H 472K-T
C401	4030006880	S.CER C1608 JB 1H 472K-T
C402	4030006860	S.CER C1608 JB 1H 102K-T
C407	4030006850	S.CER C1608 JB 1H 471K-T
C408	4030006860	S.CER C1608 JB 1H 102K-T
C409	4030011600	S.CER C1608 JB 1E 104K-T
C410	4030006860	S.CER C1608 JB 1H 102K-T
C411	4030006860	S.CER C1608 JB 1H 102K-T
C412	4030006860	S.CER C1608 JB 1H 102K-T
C414	4030006850	S.CER C1608 JB 1H 471K-T
C418	4030006860	S.CER C1608 JB 1H 102K-T
C419	4030006860	S.CER C1608 JB 1H 102K-T [OTH], [ITA], [ITR], [OTH-1], [ITA-1], [ITR-1], [CHN], [CHN-01] only
C421	4030006860	S.CER C1608 JB 1H 102K-T
C422	4030006860	S.CER C1608 JB 1H 102K-T
C423	4030006860	S.CER C1608 JB 1H 102K-T
C425	4030006860	S.CER C1608 JB 1H 102K-T
C427	4030006860	S.CER C1608 JB 1H 102K-T
C452	4030006990	S.CER C1608 CH 1H 080D-T
C453	4030006860	S.CER C1608 JB 1H 102K-T
C454	4030006860	S.CER C1608 JB 1H 102K-T
C455	4030009530	S.CER C1608 CH 1H 030B-T
C457	4030006860	S.CER C1608 JB 1H 102K-T
C458	4030006860	S.CER C1608 JB 1H 102K-T
C459	4030006860	S.CER C1608 JB 1H 102K-T
C460	4030007010	S.CER C1608 CH 1H 100D-T
C461	4030006860	S.CER C1608 JB 1H 102K-T
C462	4030009530	S.CER C1608 CH 1H 030B-T
C463	4030011600	S.CER C1608 JB 1E 104K-T
C469	4030011600	S.CER C1608 JB 1E 104K-T

S.=Surface mount

[PA UNIT]

REF NO.	ORDER NO.	DESCRIPTION
C470	4030006860	S.CER C1608 JB 1H 102K-T
C471	4030009500	S.CER C1608 CH 1H 0R5B-T
C472	4030007030	S.CER C1608 CH 1H 150J-T
C476	4030006860	S.CER C1608 JB 1H 102K-T
C477	4030011600	S.CER C1608 JB 1E 104K-T
C478	4030011600	S.CER C1608 JB 1E 104K-T
C501	4030011600	S.CER C1608 JB 1E 104K-T
C502	4030006880	S.CER C1608 JB 1H 472K-T
C511	4030011600	S.CER C1608 JB 1E 104K-T
C521	4030006880	S.CER C1608 JB 1H 472K-T
C531	4030006880	S.CER C1608 JB 1H 472K-T
C552	4030006860	S.CER C1608 JB 1H 102K-T
C553	4030006860	S.CER C1608 JB 1H 102K-T
C571	4030006880	S.CER C1608 JB 1H 472K-T
C572	4030006880	S.CER C1608 JB 1H 472K-T
C573	4030011600	S.CER C1608 JB 1E 104K-T
C574	4030006880	S.CER C1608 JB 1H 472K-T
C575	4030011600	S.CER C1608 JB 1E 104K-T
C576	4510009270	S.ELE EEEHB1C220UR
C577	4030011600	S.CER C1608 JB 1E 104K-T
C578	4510004591	ELE 16 ME 470 HC
C579	4030011600	S.CER C1608 JB 1E 104K-T
C580	4030006860	S.CER C1608 JB 1H 102K-T
C581	4030006880	S.CER C1608 JB 1H 472K-T
C582	4030006860	S.CER C1608 JB 1H 102K-T
C583	4030006860	S.CER C1608 JB 1H 102K-T
C591	4030004760	S.CER C2012 JF 1H 104Z-T
C592	4030004740	S.CER C2012 JB 1H 472K-T
C593	4030011600	S.CER C1608 JB 1E 104K-T
C594	4030011600	S.CER C1608 JB 1E 104K-T
C601	4030006850	S.CER C1608 JB 1H 471K-T
C602	4030004740	S.CER C2012 JB 1H 472K-T
C603	4030004760	S.CER C2012 JF 1H 104Z-T
C604	4510004601	ELE 16 ME 1000 HC
C613	4030011600	S.CER C1608 JB 1E 104K-T
C621	4030011600	S.CER C1608 JB 1E 104K-T
C622	4030011600	S.CER C1608 JB 1E 104K-T
C623	4030011600	S.CER C1608 JB 1E 104K-T
C624	4030006880	S.CER C1608 JB 1H 472K-T
C626	4030006860	S.CER C1608 JB 1H 102K-T
C627	4030011600	S.CER C1608 JB 1E 104K-T
C632	4030011600	S.CER C1608 JB 1E 104K-T
C641	4030006880	S.CER C1608 JB 1H 472K-T
C651	4030006880	S.CER C1608 JB 1H 472K-T
C652	4030011600	S.CER C1608 JB 1E 104K-T
C661	4030011600	S.CER C1608 JB 1E 104K-T
C662	4030011600	S.CER C1608 JB 1E 104K-T
C663	4030011600	S.CER C1608 JB 1E 104K-T
C664	4030011600	S.CER C1608 JB 1E 104K-T
C665	4030011600	S.CER C1608 JB 1E 104K-T
C666	4030011600	S.CER C1608 JB 1E 104K-T
C669	4030011600	S.CER C1608 JB 1E 104K-T
C670	4030011600	S.CER C1608 JB 1E 104K-T
C672	4030006850	S.CER C1608 JB 1H 471K-T
C673	4030006850	S.CER C1608 JB 1H 471K-T
C674	4030006850	S.CER C1608 JB 1H 471K-T
C675	4030006850	S.CER C1608 JB 1H 471K-T
C676	4030011600	S.CER C1608 JB 1E 104K-T
C677	4030011600	S.CER C1608 JB 1E 104K-T
C678	4030011600	S.CER C1608 JB 1E 104K-T
C679	4030011600	S.CER C1608 JB 1E 104K-T
C680	4030011600	S.CER C1608 JB 1E 104K-T
C681	4030011600	S.CER C1608 JB 1E 104K-T
C682	4030011600	S.CER C1608 JB 1E 104K-T
C683	4030011600	S.CER C1608 JB 1E 104K-T
C684	4030011600	S.CER C1608 JB 1E 104K-T
C685	4030006860	S.CER C1608 JB 1H 102K-T
C686	4030006860	S.CER C1608 JB 1H 102K-T
C687	4030006860	S.CER C1608 JB 1H 102K-T
C688	4030006860	S.CER C1608 JB 1H 102K-T
C689	4030006860	S.CER C1608 JB 1H 102K-T
C690	4030007170	S.CER C1608 CH 1H 221J-T
C691	4030007170	S.CER C1608 CH 1H 221J-T
C692	4030006860	S.CER C1608 JB 1H 102K-T
C693	4030006860	S.CER C1608 JB 1H 102K-T
C694	4030006850	S.CER C1608 JB 1H 471K-T [ESP], [ITR], [ITR-1], [CHN], [CHN-01] only
C695	4030006850	S.CER C1608 JB 1H 471K-T [ESP], [ITR], [ITR-1], [CHN], [CHN-01] only
C696	4030010750	S.CER C1608 CH 1H 201J-T [ESP], [ITR], [ITR-1], [CHN], [CHN-01] only
C697	4030007090	S.CER C1608 CH 1H 470J-T [ESP], [ITR], [ITR-1], [CHN], [CHN-01] only
C702	4030007170	S.CER C1608 CH 1H 221J-T
C711	4030010750	S.CER C1608 CH 1H 201J-T [ESP], [ITR], [ITR-1], [CHN], [CHN-01] only
C712	4030006860	S.CER C1608 JB 1H 102K-T [ESP], [ITR], [ITR-1], [CHN], [CHN-01] only
C716	4030007090	S.CER C1608 CH 1H 470J-T [ESP], [ITR], [ITR-1], [CHN], [CHN-01] only
C717	4030007170	S.CER C1608 CH 1H 221J-T
C718	4030007090	S.CER C1608 CH 1H 470J-T [ESP], [ITR], [CHN], [CHN-01] only
RL591	6330001550	RLY JV-12-KT
CP573	6910009670	S.CHK HK3-S-T
CP574	6910009670	S.CHK HK3-S-T
J160	6510021531	CNR IMSA-9230B-1-04Z024-PT1

[PA UNIT]

REF NO.	ORDER NO.	DESCRIPTION
J161	6510021531	CNR IMSA-9230B-1-04Z024-PT1
J172	6510007020	CNR TMP-J01X-V6
J210	6510021531	CNR IMSA-9230B-1-04Z024-PT1
J211	6510021531	CNR IMSA-9230B-1-04Z024-PT1
J270	6510017150	CNR TMP-S01X-C1
J571	6510018961	S.CNR B2B-PH-SM4-TB (LF) (SN)
J621	6510019981	S.CNR 52808-1671 (1690)
J641	6450000140	CNR HSJ0807-01-010
J661	6510020081	S.CNR 52808-2071 (2090)
F591	5210000131	FUS FGB 4A PBF (FGB0 125V)
F592	5220000230	HOL S-N5054
F593	5220000230	HOL S-N5054
W185	7030009300	S.RES ERJ1WY0R00U except [USA], [USA-1], [EUR], [EUR-1]
W186	7030009300	S.RES ERJ1WY0R00U except [USA], [USA-1], [EUR], [EUR-1]
W235	7030000010	S.RES MCR10EZHZ JPW (000)
W300	7030008240	S.RES ERJ12Y0R00U
W301	7030008240	S.RES ERJ12Y0R00U
W316	7030003860	S.RES ERJ3GE JPW V
W320	7030003860	S.RES ERJ3GE JPW V
W361	9056200200	WIR 73/98/012/X98/X98 except [EUR], [FRA], [USA]
W462	7030003860	S.RES ERJ3GE JPW V
W572	7030003860	S.RES ERJ3GE JPW V
EP121	9040901901	TUB IRRAX 0.7 (d) L=12 mm
EP174	9018970370	TUB 20 L=25MM

[FILTER BOARD]

REF NO.	ORDER NO.	DESCRIPTION
IC1	1110002700	S.IC NJM2904M-TE1
Q1	1590000680	S.TR DTC114EUA T106
Q2	1530002060	S.TR 2SC4081 T106 R
Q3	1530002060	S.TR 2SC4081 T106 R
Q4	1530002060	S.TR 2SC4081 T106 R
Q5	1530002060	S.TR 2SC4081 T106 R
Q6	1530002060	S.TR 2SC4081 T106 R
Q7	1530002060	S.TR 2SC4081 T106 R
Q8	1530002060	S.TR 2SC4081 T106 R
Q9	1530003091	S.TR 2SC4213-B (TE85R,F)
Q10	1530002060	S.TR 2SC4081 T106 R
Q11	1540000451	S.TR 2SD1623T-TD-E
Q12	1590001870	S.TR DTA114EE TL
D1	1750000301	S.DIO 1SS302 (TE85R,F)
D2	1750000301	S.DIO 1SS302 (TE85R,F)
D3	1750000301	S.DIO 1SS302 (TE85R,F)
D4	1750000301	S.DIO 1SS302 (TE85R,F)
D5	1750000301	S.DIO 1SS302 (TE85R,F)
D6	1750000301	S.DIO 1SS302 (TE85R,F)
D7	1750000301	S.DIO 1SS302 (TE85R,F)
D8	1750000301	S.DIO 1SS302 (TE85R,F)
D9	1790000980	S.DIO MA742 (TX)
D10	1790000980	S.DIO MA742 (TX)
D23	1750000301	S.DIO 1SS302 (TE85R,F)
D24	1160000050	S.DIO DAP202U T106
D25	1750000641	S.DIO 1SV312 (TE85L,F)
D26	1790001250	S.DIO MA2S111-(TX)
L1	6110001560	COL LA-236
L2	6110001630	COL LA-246
L5	6110003570	COL LA-550
L6	6110003570	COL LA-550
L7	6110003550	COL LA-547 (LA-214A)
L10	6140001800	COL LR-216 (T50-2)
L11	6140001800	COL LR-216 (T50-2)
L14	6140003450	COL LR-387 (T50-10) except [USA], [USA-1]
L15	6140003540	COL LR-396 except [USA], [USA-1], [EUR], [EUR-1]
L16	6140003460	COL LR-388 (T50-10) except [USA], [USA-1], [EUR], [EUR-1]
L18	6140002560	COL LR-293 (T50-10)
L19	6140002560	COL LR-293 (T50-10)
L22	6110002920	COL LA-481
L23	6110003580	COL LA-551
L26	6140001800	COL LR-216 (T50-2)
L27	6140001780	COL LR-214 (T50-2)
L30	6140002570	COL LR-294 (T50-2)
L31	6140002580	COL LR-295 (T50-2)
L33	6140003490	COL LR-391 (TR10X5X5 3A6)
L34	6200002041	S.COL NLV25T-101J
L35	6200003950	S.COL HF50ACC 322513-T
L36	6200002041	S.COL NLV25T-101J
L37	6200002041	S.COL NLV25T-101J
L39	6200003950	S.COL HF50ACC 322513-T
L41	6200003950	S.COL HF50ACC 322513-T
L42	6200003950	S.COL HF50ACC 322513-T
L43	6200003950	S.COL HF50ACC 322513-T
L44	6200002041	S.COL NLV25T-101J

S.=Surface mount



[FILTER BOARD]

REF NO.	ORDER NO.	DESCRIPTION
L45	6200002041	S.COL NLV25T-101J
L46	6200002041	S.COL NLV25T-101J
L47	6200002041	S.COL NLV25T-101J
L48	6200002041	S.COL NLV25T-101J
L49	6200002041	S.COL NLV25T-101J
L50	6140002560	COL LR-293 (T50-10)
L51	6200003950	S.COL HF50ACC 322513-T
L54	6200002041	S.COL NLV25T-101J
L55	6200002041	S.COL NLV25T-101J
L56	6200005011	S.COL NLV25T-100J
L57	6200002041	S.COL NLV25T-101J
L58	6200003950	S.COL HF50ACC 322513-T
L59	6200003950	S.COL HF50ACC 322513-T
L60	6200002041	S.COL NLV25T-101J
L61	6200003950	S.COL HF50ACC 322513-T
L63	6200005011	S.COL NLV25T-100J
L64	6200002041	S.COL NLV25T-101J
L65	6200002041	S.COL NLV25T-101J
L66	6200002041	S.COL NLV25T-101J
L67	6200002041	S.COL NLV25T-101J
L68	6200003590	S.COL EXCCCL3225U1
L69	6200002041	S.COL NLV25T-101J
L70	6200003550	S.COL MLF1608A 4R7K-T
L71	6200002041	S.COL NLV25T-101J
L72	6200002041	S.COL NLV25T-101J
L73	6200002041	S.COL NLV25T-101J
L74	6200002041	S.COL NLV25T-101J
L75	6200002041	S.COL NLV25T-101J
L76	6200002041	S.COL NLV25T-101J
L77	6200002041	S.COL NLV25T-101J
L78	6200002041	S.COL NLV25T-101J
L79	6200002041	S.COL NLV25T-101J
L80	6200002041	S.COL NLV25T-101J
L81	6200002041	S.COL NLV25T-101J
L82	6200002041	S.COL NLV25T-101J
L83	6200002041	S.COL NLV25T-101J
L84	6200002041	S.COL NLV25T-101J
L85	6200002041	S.COL NLV25T-101J
L86	6200002041	S.COL NLV25T-101J
L87	6200002041	S.COL NLV25T-101J
L200	6200003331	S.COL NLV32T-1R0J
L201	6200003331	S.COL NLV32T-1R0J
R2	7030008190	S.RES ERJ12YJ330U (33)
R3	7030003560	S.RES ERJ3GEYJ 103 V (10 k)
R4	7030003550	S.RES ERJ3GEYJ 822 V (8.2 k)
R5	7030003440	S.RES ERJ3GEYJ 102 V (1 k)
R6	7030003640	S.RES ERJ3GEYJ 473 V (47 k)
R7	7030003680	S.RES ERJ3GEYJ 104 V (100 k)
R8	7540000130	ABS 2P-50A-301
R9	7030003320	S.RES ERJ3GEYJ 101 V (100)
R10	7030003320	S.RES ERJ3GEYJ 101 V (100)
R11	7030006220	S.RES ERJ12YJ470U (47) except [USA], [USA-1], [EUR], [EUR-1]
R15	7030003440	S.RES ERJ3GEYJ 102 V (1 k)
R16	7030003320	S.RES ERJ3GEYJ 101 V (100)
R17	7030003440	S.RES ERJ3GEYJ 102 V (1 k)
R18	7030003320	S.RES ERJ3GEYJ 101 V (100)
R26	7030003560	S.RES ERJ3GEYJ 103 V (10 k)
R27	7030003440	S.RES ERJ3GEYJ 102 V (1 k)
R28	7030003440	S.RES ERJ3GEYJ 102 V (1 k)
R33	7030003440	S.RES ERJ3GEYJ 102 V (1 k)
R34	7030003440	S.RES ERJ3GEYJ 102 V (1 k)
R35	7030003440	S.RES ERJ3GEYJ 102 V (1 k)
R36	7030003440	S.RES ERJ3GEYJ 102 V (1 k)
R37	7030003440	S.RES ERJ3GEYJ 102 V (1 k)
R38	7030003440	S.RES ERJ3GEYJ 102 V (1 k)
R39	7030003440	S.RES ERJ3GEYJ 102 V (1 k)
R40	7030003440	S.RES ERJ3GEYJ 102 V (1 k)
R42	7030003480	S.RES ERJ3GEYJ 222 V (2.2 k)
R43	7030003480	S.RES ERJ3GEYJ 222 V (2.2 k)
R60	7030003480	S.RES ERJ3GEYJ 222 V (2.2 k)
R61	7030003320	S.RES ERJ3GEYJ 101 V (100)
R62	7030003390	S.RES ERJ3GEYJ 391 V (390)
R63	7030003290	S.RES ERJ3GEYJ 560 V (56)
R64	7030003720	S.RES ERJ3GEYJ 224 V (220 k)
R65	7030003720	S.RES ERJ3GEYJ 224 V (220 k)
R66	7030003520	S.RES ERJ3GEYJ 472 V (4.7 k)
R67	7030000320	S.RES MCR10EZJH 330 (331)
R68	7030003440	S.RES ERJ3GEYJ 102 V (1 k)
R69	7030003560	S.RES ERJ3GEYJ 103 V (10 k)
R70	7030003440	S.RES ERJ3GEYJ 102 V (1 k)
R71	7030003560	S.RES ERJ3GEYJ 103 V (10 k)
R72	7030003440	S.RES ERJ3GEYJ 102 V (1 k)
R73	7030003560	S.RES ERJ3GEYJ 103 V (10 k)
R74	7030003440	S.RES ERJ3GEYJ 102 V (1 k)
R75	7030003560	S.RES ERJ3GEYJ 103 V (10 k)
R76	7030003440	S.RES ERJ3GEYJ 102 V (1 k)
R77	7030003560	S.RES ERJ3GEYJ 103 V (10 k)
R78	7030003440	S.RES ERJ3GEYJ 102 V (1 k)
R79	7030003560	S.RES ERJ3GEYJ 103 V (10 k)
R80	7030003440	S.RES ERJ3GEYJ 102 V (1 k)
R81	7030003560	S.RES ERJ3GEYJ 103 V (10 k)
R82	7030003440	S.RES ERJ3GEYJ 102 V (1 k)
R83	7030003560	S.RES ERJ3GEYJ 103 V (10 k)
C1	4030007070	S.CER C1608 CH 1H 330J-T
C2	4030009470	S.CER C1608 CH 1H R75C-T
C3	4030007100	S.CER C1608 CH 1H 560J-T
C4	4030007030	S.CER C1608 CH 1H 150J-T
C5	4030007080	S.CER C1608 CH 1H 390J-T
C6	4030006880	S.CER C1608 JB 1H 472K-T

[FILTER BOARD]

REF NO.	ORDER NO.	DESCRIPTION
C7	4030006880	S.CER C1608 JB 1H 472K-T
C8	4030006880	S.CER C1608 JB 1H 472K-T
C9	4030011340	S.CER C1608 CH 1H 471J-T
C11	4030011340	S.CER C1608 CH 1H 471J-T
C15	4030006880	S.CER C1608 JB 1H 472K-T
C16	4030006880	S.CER C1608 JB 1H 472K-T
C17	4010005360	CER HM11SJ SL 301J 500V
C19	4010007590	CER HM15SJ SL 681J 500V
C21	4010005930	CER HM11SJ SL 391J 500V
C22	4030006880	S.CER C1608 JB 1H 472K-T
C23	4030006880	S.CER C1608 JB 1H 472K-T
C29	4030006880	S.CER C1608 JB 1H 472K-T
C30	4030006880	S.CER C1608 JB 1H 472K-T
C31	4010007610	CER HM95SJ SL 241J 500V
C32	4010005810	CER HM74SJ SL 111J 500V
C33	4010005880	CER HM95SJ SL 271J 500V
C36	4030006880	S.CER C1608 JB 1H 472K-T
C37	4030006880	S.CER C1608 JB 1H 472K-T
C40	4010007610	CER HM95SJ SL 241J 500V
C43	4030006880	S.CER C1608 JB 1H 472K-T
C44	4030006880	S.CER C1608 JB 1H 472K-T
C45	4010005930	CER HM11SJ SL 391J 500V
C46	4010008160	CER HM13SJ SL 431J 500V
C47	4010005870	CER HM95SJ SL 221J 500V
C48	4010005810	CER HM74SJ SL 111J 500V
C49	4010007490	CER HM15SJ SL 561J 500V
C50	4030006880	S.CER C1608 JB 1H 472K-T
C51	4030006880	S.CER C1608 JB 1H 472K-T
C52	4010007500	CER HM15SJ SL 751J 500V
C53	4010006410	CER HM13SJ SL 471J 500V
C54	4010007500	CER HM15SJ SL 751J 500V
C55	4010005820	CER HM74SJ SL 121J 500V
C56	4010007500	CER HM15SJ SL 751J 500V
C57	4030006880	S.CER C1608 JB 1H 472K-T
C58	4610002120	S.TRI TZB4Z100EB10R00 (TZB4Z100BE110)
C59	4030011830	S.CER C1608 CH 1H 301J-T
C60	4030006970	S.CER C1608 CH 1H 060D-T
C62	4030010760	S.CER C1608 CH 1H 331J-T
C63	4030010760	S.CER C1608 CH 1H 331J-T
C64	4030007090	S.CER C1608 CH 1H 470J-T
C65	4030006850	S.CER C1608 JB 1H 471K-T
C66	4030006850	S.CER C1608 JB 1H 471K-T
C67	4030006850	S.CER C1608 JB 1H 471K-T
C69	4030006880	S.CER C1608 JB 1H 472K-T
C70	4030006880	S.CER C1608 JB 1H 472K-T
C71	4030006880	S.CER C1608 JB 1H 472K-T
C72	4030006880	S.CER C1608 JB 1H 472K-T
C73	4030006880	S.CER C1608 JB 1H 472K-T
C74	4030006880	S.CER C1608 JB 1H 472K-T
C75	4030006880	S.CER C1608 JB 1H 472K-T
C76	4030006880	S.CER C1608 JB 1H 472K-T
C78	4010005850	CER HM95SJ SL 181J 500V
C79	4010005860	CER HM95SJ SL 201J 500V
C80	4010007590	CER HM15SJ SL 681J 500V
C81	4010006410	CER HM13SJ SL 471J 500V
C82	4010007500	CER HM15SJ SL 751J 500V
C84	4010007490	CER HM15SJ SL 561J 500V
C87	4030006880	S.CER C1608 JB 1H 472K-T
C88	4030006880	S.CER C1608 JB 1H 472K-T
C89	4030006880	S.CER C1608 JB 1H 472K-T
C90	4030006880	S.CER C1608 JB 1H 472K-T
C91	4030006880	S.CER C1608 JB 1H 472K-T
C92	4030006880	S.CER C1608 JB 1H 472K-T
C93	4030006880	S.CER C1608 JB 1H 472K-T
C94	4030006880	S.CER C1608 JB 1H 472K-T
C95	4030006880	S.CER C1608 JB 1H 472K-T
C96	4030006880	S.CER C1608 JB 1H 472K-T
C97	4030006880	S.CER C1608 JB 1H 472K-T
C98	4030006880	S.CER C1608 JB 1H 472K-T
C99	4030006880	S.CER C1608 JB 1H 472K-T
C100	4030006880	S.CER C1608 JB 1H 472K-T
C101	4030006860	S.CER C1608 JB 1H 102K-T
C102	4030006880	S.CER C1608 JB 1H 472K-T
C103	4030006880	S.CER C1608 JB 1H 472K-T
C104	4030006880	S.CER C1608 JB 1H 472K-T
C105	4030006880	S.CER C1608 JB 1H 472K-T
C110	4030006880	S.CER C1608 JB 1H 472K-T
C111	4030006880	S.CER C1608 JB 1H 472K-T
C112	4030006880	S.CER C1608 JB 1H 472K-T
C113	4030006880	S.CER C1608 JB 1H 472K-T
C114	4030006880	S.CER C1608 JB 1H 472K-T
C115	4030006880	S.CER C1608 JB 1H 472K-T
C116	4030006880	S.CER C1608 JB 1H 472K-T
C117	4030006880	S.CER C1608 JB 1H 472K-T
C118	4030006880	S.CER C1608 JB 1H 472K-T
C119	4030006880	S.CER C1608 JB 1H 472K-T
C120	4030006880	S.CER C1608 JB 1H 472K-T
C121	4030006880	S.CER C1608 JB 1H 472K-T
C122	4030006880	S.CER C1608 JB 1H 472K-T
C123	4030006880	S.CER C2012 JF 1C 105Z-T
C124	4030011600	S.CER C1608 JB 1E 104K-T
C125	4030011600	S.CER C1608 JB 1E 104K-T
C126	4030011600	S.CER C1608 JB 1E 104K-T
C127	4030011600	S.CER C1608 JB 1E 104K-T
C128	4030006880	S.CER C1608 JB 1H 472K-T
C133	4030011600	S.CER C1608 JB 1E 104K-T
C135	4010005820	CER HM74SJ SL 121J 500V
C136	4030011790	S.CER GRM55RF52A684ZD01L (GRM44-1)
C140	4030006860	S.CER C1608 JB 1H 102K-T
C141	4030006860	S.CER C1608 JB 1H 102K-T
C143	4010006410	CER HM13SJ SL 471J 500V
C144	4030006880	S.CER C1608 JB 1H 472K-T
C145	4030006880	S.CER C1608 JB 1H 472K-T
C146	4030006880	S.CER C1608 JB 1H 472K-T

S.=Surface mount

[FILTER BOARD]

REF NO.	ORDER NO.	DESCRIPTION
C147	4030006880	S.CER C1608 JB 1H 472K-T
C148	4030006880	S.CER C1608 JB 1H 472K-T
C149	4030011600	S.CER C1608 JB 1E 104K-T
C151	4010005540	CER HM60SJ SL 030C 500V
C152	4030006860	S.CER C1608 JB 1H 102K-T
C153	4030006880	S.CER C1608 JB 1H 472K-T
C154	4030006880	S.CER C1608 JB 1H 472K-T
C155	4030006880	S.CER C1608 JB 1H 472K-T
C156	4030006880	S.CER C1608 JB 1H 472K-T
C157	4030006880	S.CER C1608 JB 1H 472K-T
C158	4030006880	S.CER C2012 JF 1C 105Z-T
C159	4030006880	S.CER C1608 JB 1H 472K-T
C162	4030011080	S.CER GRM31M2C2H6R0DV01L (GRM42-6 CH)
C164	4030011160	S.CER GRM31M2C2H150JV01L (GRM42-6 CH)
C165	4030011240	S.CER GRM31M2C2H470JV01L (GRM42-6 CH) except [ITA], [FRA-1], [ITA-1], [ITR-1]
C166	4030011240	S.CER GRM31M2C2H470JV01L (GRM42-6 CH)
C168	4030011210	S.CER GRM31M2C2H330JV01L (GRM42-6 CH) [ESP], [OTH], [ITR], [OTH-1], [CHN], [CHN-01] only
C169	4030011180	S.CER GRM31M2C2H220JV01L (GRM42-6 CH)
C170	4030011170	S.CER GRM31M2C2H180JV01L (GRM42-6 CH)
C171	4030011160	S.CER GRM31M2C2H150JV01L (GRM42-6 CH) [ESP], [USA] [OTH], [ITA], [ITR], [USA-1], [OTH-1], [CHN], [CHN-01] only
C172	4030011180	S.CER GRM31M2C2H220JV01L (GRM42-6 CH)
C174	4030011510	S.CER GRM31M2C2H560JV01L (GRM42-6 CH)
C175	4030011730	S.CER GRM31M2C2H101JV01L (GRM42-6 CH)
C176	4030011730	S.CER GRM31M2C2H101JV01L (GRM42-6 CH)
C177	4030011180	S.CER GRM31M2C2H220JV01L (GRM42-6 CH)
C178	4030011240	S.CER GRM31M2C2H470JV01L (GRM42-6 CH)
C180	4030011550	S.CER GRM31M2C2H680JV01L (GRM42-6 CH)
C181	4030011730	S.CER GRM31M2C2H101JV01L (GRM42-6 CH) [EUR], [FRA], except [USA], [USA-1], [EUR], [EUR-1] only
C182	4030011180	S.CER GRM31M2C2H220JV01L (GRM42-6 CH)
C183	4030011730	S.CER GRM31M2C2H101JV01L (GRM42-6 CH)
C184	4030011730	S.CER GRM31M2C2H101JV01L (GRM42-6 CH)
C185	4030011210	S.CER GRM31M2C2H330JV01L (GRM42-6 CH)
C186	4030011730	S.CER GRM31M2C2H101JV01L (GRM42-6 CH)
C188	4030011120	S.CER GRM31M2C2H100JV01L (GRM42-6 CH)
C189	4030011600	S.CER C1608 JB 1E 104K-T
C190	4030011600	S.CER C1608 JB 1E 104K-T
C191	4030011600	S.CER C1608 JB 1E 104K-T
C192	4030011600	S.CER C1608 JB 1E 104K-T
C200	4030011180	S.CER GRM31M2C2H220JV01L (GRM42-6 CH)
C201	4030011190	S.CER GRM31M2C2H270JV01L (GRM42-6 CH)
C202	4030006880	S.CER C1608 JB 1H 472K-T
C203	4030006860	S.CER C1608 JB 1H 102K-T
C204	4030007090	S.CER C1608 CH 1H 470J-T
C205	4030006860	S.CER C1608 JB 1H 102K-T
C206	4030006860	S.CER C1608 JB 1H 102K-T
C207	4030006860	S.CER C1608 JB 1H 102K-T
C208	4030006860	S.CER C1608 JB 1H 102K-T
C209	4030006860	S.CER C1608 JB 1H 102K-T
C210	4030006860	S.CER C1608 JB 1H 102K-T
C211	4030006860	S.CER C1608 JB 1H 102K-T
C213	4030012610	S.CER C2012 JB 1C 474K-T
C214	4030006880	S.CER C1608 JB 1H 472K-T
C215	4030011600	S.CER C1608 JB 1E 104K-T
C216	4030011120	S.CER GRM31M2C2H100JV01L (GRM42-6 CH)
C217	4030011210	S.CER GRM31M2C2H330JV01L (GRM42-6 CH)
C218	4030011730	S.CER GRM31M2C2H101JV01L (GRM42-6 CH) except [USA], [USA-1], [EUR], [EUR-1]
C219	4030007090	S.CER C1608 CH 1H 470J-T [ESP], [ITR], [ITR-1], [CHN], [CHN-01] only
RL1	6330001330	RLY AG 201344
RL2	6330001430	RLY NA-12W-K
RL3	6330001430	RLY NA-12W-K
RL4	6330001150	RLY MZ-12DK
RL5	6330001150	RLY MZ-12DK
RL6	6330001150	RLY MZ-12DK
RL7	6330001150	RLY MZ-12DK
RL8	6330001150	RLY MZ-12DK
RL9	6330001150	RLY MZ-12DK
RL10	6330001150	RLY MZ-12DK
RL11	6330001150	RLY MZ-12DK
RL12	6330001150	RLY MZ-12DK
RL13	6330001150	RLY MZ-12DK
RL14	6330001150	RLY MZ-12DK
RL15	6330001150	RLY MZ-12DK
RL16	6330001150	RLY MZ-12DK
J4	6450001491	CNR HLJ7001-016010
J5	6510024661	CNR TCS5072-1041577
J7	6450001650	CNR HSJ0836-01-500
J8	6450001660	CNR EX345GLB
J9	6510020081	S.CNR 52808-2071 (2090)
J11	6510016171	CNR 52018-8836
J12	6510020081	S.CNR 52808-2071 (2090)
J13	6510017150	CNR TMP-S01X-C1
J14	6450001841	CNR TCS7568-4320177
W15	7030003860	S.RES ERJ3GE JPW V
W16	7030003860	S.RES ERJ3GE JPW V
W17	7030003860	S.RES ERJ3GE JPW V
W18	7030003860	S.RES ERJ3GE JPW V
W19	7030009300	S.RES ERJ1WY0R00U
W20	7030009300	S.RES ERJ1WY0R00U
W23	7030003860	S.RES ERJ3GE JPW V
W24	7030000010	S.RES MCR10EZHZ JPW (000)
EP5	6910012350	S.BEA MMZ1608Y 102BT
EP7	6910012350	S.BEA MMZ1608Y 102BT

[DRIVER BOARD]

REF NO.	ORDER NO.	DESCRIPTION
Q100	1590003121	S.FET MRF1518NT1
Q200	1590003121	S.FET MRF1518NT1
R165	7030010480	S.RES ERJ1TYJ 181U (180)
R166	7030000020	S.RES MCR10EZHZJ 1 (010) [ESP], [OTH], [CHN], [CHN-01] only
C168	4030006480	S.CER GRM319B11H104KA01D (GRM42-6)
C169	4030011740	S.CER GRM32N2C2H201JV01L (GRM42-2 CH)
C216	4030011240	S.CER GRM31M2C2H470JV01L (GRM42-6 CH)
W213	7030000010	S.RES MCR10EZHZJ JPW (000)

[VR BOARD]

REF NO.	ORDER NO.	DESCRIPTION
R1	7210002780	VAR RV-300 (RK0972210) 10KB/10KB
R2	7210002940	VAR TP96D231E20-20F-10KB-1897
J1	6510018891	S.CNR 52559-1370 (1390)
S1	2220000540	SW SW-162 (SSSS22-2-11)

S.=Surface mount

# SECTION 6

# MECHANICAL PARTS AND DISASSEMBLY

## [CHASSIS PARTS]

REF NO.	ORDER NO.	DESCRIPTION	QTY.
J3	6510000370	MR-DS	1
J4	6510000370	MR-DS	1
P3	6510009330	51006-0200	1
P4	6510003240	TMP-P01X-A1	1
SP1	2510000991	VS-C66Y0811A	1
MF1	2710000580	FBA06T12HF	1
W1	8900008850	OPC-874	1
W2	8900015940	OPC-875A	1
W3	8900015020	OPC-877A	1
W4	9016910510	51/99/160/A14A/W99A	1
W5	9011130780	Wire 00	1
W12	9016910450	62/99/075/C31/W17D	1
W13	9086700300	Wire 08	1
W14	8900008700	OPC-852	1
W15	8900008870	OPC-876	1
EP4	6910000630	FSOH070RN	1
EP5	9068000100	Wire D=5.0 L=10MM	1
EP7	9010001410	Wire D=8.0	1
EP8	6910009680	H-110-02 L=50MM	1
EP9†	-	UT-106 [EUR-1], [FRA-1], [ESP-1], [USA-1], [OTH-1], [ITA-1], [ITR-1] only	1
EP10	9019501210	Wire D=7.0	1
MP1	8010017543	2177 CHASSIS-3	1
MP2	8110006061	1897 U-COVER-1	1
MP3	8110006591	2177 L-COVER-1	1
MP4	8010001490	stand (D)	1
MP5	8930005790	Color reg (A)	1
MP6	8930005800	Color reg (B)	1
MP7	8930049123	2177 FAN HOLDER-3	1
MP8	8820000530	Flange bolt M4X8 NI	1
MP9	8930002820	rubber leg (D) SK136A	2
MP10	8930015850	Speaker net (SX-611)	1
MP11	8930018520	TR clip (A)	1
MP12	8950004181	1691 CONTACT BASE (A)-1	1
MP14	8930052330	sponge (GN)	1
MP17	8310045920	2177 ANT PLATE	1
MP19	8810008661	Screw BT B0 3X8 NI-ZC3 (BT)	5
MP20	8810007410	Screw PH M3X6 NI	2
MP21	8810009611	Screw M2.6X6 ZK3	5
MP22	8850000140	Flat washer M4 BS NI	1
MP24	8810008991	Screw BT B0 2X10NI-ZK3 (BT)	1
MP25	8850001561	TOOTHED WASHER (A) M4 ZC3	1
MP26	8810008661	Screw BT B0 3X8 NI-ZC3 (BT)	4
MP27	8810008661	Screw BT B0 3X8 NI-ZC3 (BT)	5
MP28	8810008661	Screw BT B0 3X8 NI-ZC3 (BT)	6
MP29	8810004431	Screw PH M3X6 ZK3	2
MP30	8810004431	Screw PH M3X6 ZK3	2
MP31	8810004431	Screw PH M3X6 ZK3	2
MP32	8810007410	Screw PH M3X6 NI	2
MP33	8810008490	Setscrew (H) 2.6X8 NI	2
MP34	8810008490	Setscrew (H) 2.6X8 NI	2
MP35	8810008490	Setscrew (H) 2.6X8 NI	2
MP36	8810009611	Screw M2.6X6 ZK3	5
MP37	8810008490	Setscrew (H) 2.6X8 NI	2
MP38	8930038650	Thermal sheet (BE)	1
MP40	8930038820	aluminium sheet (V)	1
MP49	8930028390	Thermal sheet (AH)	5
MP60	8930042441	1897 SP HOLDER-1	1
MP61	8810009611	Screw M2.6X6 ZK3	4
MP62	8810009391	Screw BT B0 3X18NI-ZC3 (BT)	4
MP63	8810007410	Screw PH M3X6 NI	2
MP65	8810008661	Screw BT B0 3X8 NI-ZC3 (BT)	2
MP74	8510011940	2177 PLATE	1
MP75	8810009511	Screw BT B0 2X4 NI-ZC3 (BT)	2
MP76	8510006440	ANT cover	1
MP77	8930048550	2177 CLIP	1
MP79	8930048960	SHIELD TAPE (B)	1
MP80	8930048970	SHIELD TAPE (C)	1
MP81	8930048960	SHIELD TAPE (B)	1
MP82	8930045920	2056 SPONGE	1
MP83	8930015640	Cable holder (SX-713)	1
MP84	8930048120	SHIELD TAPE (A)	1
MP87	8930049110	sponge (GC)	1
MP89	8930049710	2177 FAN SPRING	1
MP92	8850000571	TOOTHED WASHER (B) M3 ZC3	1
MP93	8850000571	TOOTHED WASHER (B) M3 ZC3	1
MP94	8930045920	2056 SPONGE	1
MP95	8930045920	2056 SPONGE	1
MP96	8930049110	sponge (GC)	1
MP97	8930049110	sponge (GC)	1
MP98	8930056020	sponge (GU)	1
MP100	8930049130	SHIELD TAPE (D)	1
MP101	8930048960	SHIELD TAPE (B)	1
MP102	8930049130	SHIELD TAPE (D)	1
MP103	8930049130	SHIELD TAPE (D)	1
MP104	8930048970	SHIELD TAPE (C)	1
MP105	8930049130	SHIELD TAPE (D)	1
MP106	8930045920	2056 SPONGE	1
MP107	8930056010	emboss tape (K)	1
MP108	8930056160	Doublesided tape (AG)	1
MP109	8930041830	sponge (ER)	1
MP110	8930041830	sponge (ER)	1

## [FRONT UNIT]

REF NO.	ORDER NO.	DESCRIPTION	QTY.
W1	8900006040	OPC-593	1
W2	8900006252	OPC-610B	1
EP1	6910013810	RMS20-100-201-1C	1
MP1	8210015781	2177 FRONT PANEL-1	1
MP2	8210015890	1691 REAR PANEL (A)	1
MP3	8930047970	2177 MENU KEY	1
MP4	8930047960	2177 MODE KEY	1
MP5	8930048370	1691 UP/DOWN KEY (B)	1
MP6	8930036731	1691 4-KEY-1	1
MP7	8930036751	Push spring (Y)-1	1
MP8	8930060190	2591 N-SPRING	1
MP9	8830001010	HEX NUT (A)	2
MP10	8610010660	Knob N-237 (A)	1
MP11	8610010670	Knob N-238 (A)	2
MP12	8610010024	Knob N-239 BASE-4	1
MP13	8610010030	Knob N-239 COVER	1
MP14	8610010040	Knob N-239 FINGER REST	1
MP15	8930036691	1691 RELEASE BUTTON-1	1
MP16	8930048090	2177 LENS	3
MP17	8310036280	1691 WINDOW PLATE	1
MP18	8310036273	1691 BRAKE PLATE-3	1
MP19	8950004192	1691 CONTACT BASE (B)-2	1
MP20	8930036740	1691 BRAKE PAD	2
MP21	8930037111	1691 BRAKE SHEET-1	1
MP22	8310036583	1691 Warning sticker (S)-3	1
MP23	8810008991	Screw BT B0 2X10NI-ZK3 (BT)	2
MP24	8930038940	sponge (EF)	1
MP26	8610010360	Knob N-260	1
MP27	8610007510	knob spring NO.7800	1
MP28	8610007510	knob spring NO.7800	1

## [DISPLAY UNIT]

REF NO.	ORDER NO.	DESCRIPTION	QTY.
J1*	6510019121	S8B-PH-SM4-TB (LF) (SN)	1
J2	6450001630	HSJ1406-01-050	1
J3*	6510018891	52559-1370	1
DS4	5030001670	DLC-8309YBGF	1
DS5	5030001290	D2264	1
W1	7030003860	ERJ3GE-JPW	1
W2	7120000470	ERDS2T0	1
W3	7120000470	ERDS2T0	1
EP2	8930039790	SRCN-1691-ZSS-505	2
MP1	8930036710	1691 LCD HOLDER	1
MP3	8810009040	Setscrew (H) 2.6X10 NI	1
MP4	8830000180	Nut M2.6 BS NI	1
MP5	8930043471	1897 FRONT PLATE-1	1
MP6	8510014100	2177 FRONT SHIELD	1

## [VR BOARD]

REF NO.	ORDER NO.	DESCRIPTION	QTY.
R1	7210002780	RV-300	1
R2	7210002940	TP96D231E20-20F-10KB-1897	1
J1	6510018891	52559-1370	1
S1	2220000540	SW-162	1

\*: Refer to SECTION 8 "BOARD LAYOUTS."

†: Optional product

### Screw abbreviations

A, B0, BT: Self-tapping PH: Pan head ZK: Black  
NI-ZU: Nickel-Zinc SUS: Stainless

**[MAIN UNIT]**

REF NO.	ORDER NO.	DESCRIPTION	QTY.
J1*	6510021280	AXK6S20645P	1
J101	6510007020	TMP-J01X-V6	1
J141	6510007020	TMP-J01X-V6	1
J231	6510007020	TMP-J01X-V6	1
J281	6510007020	TMP-J01X-V6	1
J401*	6510020081	52808-2071	1
J431*	6510020081	52808-2071	1
J461*	6510020081	52808-2071	1
J551	6510007020	TMP-J01X-V6	1
J701	6450001560	PD-72	1
J702	6450001560	PD-72	1
J703	6450001560	PD-72	1
J704	6450001560	PD-72	1
J705	6510020381	JS0330-SN	1
J706	6510020381	JS0330-SN	1
J711	6450001560	PD-72	1
J712	6450001560	PD-72	1
J713	6450001560	PD-72	1
J714	6450001560	PD-72	1
J715	6510020381	JS0330-SN	1
J716	6510020381	JS0330-SN	1
J791*	6510018961	B2B-PH-SM4-TB (LF) (SN)	1
J1381*	6510019071	52559-3072	1
J1421*	6510020091	52808-0871	1
J1431*	6510018971	B4B-PH-SM4-TB (LF) (SN)	1
J2061*	6510019191	52365-0871	1
MP1	8510011950	2177 HPF CASE	1
MP2	8510005990	724 Shield case cover	1
MP3	8510012400	2177 D/A CASE	1
MP4	8930014140	earth spring (D)	1
MP5	8930014140	earth spring (D)	1
MP6	8310045930	2177 SHIELD PLATE	1
MP7	8510010460	1691 MAIN SHIELD PLATE	1
MP8	8930054530	2355 EARTH SPRING	1
MP9	8930017200	752 earth spring	1
MP10	8930017200	752 earth spring	1
MP14	8510012410	2177 MAIN S-PLATE	1
MP18	8930054530	2355 EARTH SPRING	1
MP19	8930014140	earth spring (D)	1

**[DRIVER BOARD]**

REF NO.	ORDER NO.	DESCRIPTION	QTY.
MP1	8410002270	2177 HEATSINK	1

**[PLL UNIT]**

REF NO.	ORDER NO.	DESCRIPTION	QTY.
RL231	6330000621	SY-12-K	1
CP281*	6910009670	HK3-S-T	1
CP282*	6910009670	HK3-S-T	1
J251	6510009890	PD054-04M	1
J252*	6510019981	52808-1671	1
J253*	6510019971	52808-1071	1
J254*	6510019071	52559-3072	1
J681	6510007900	TBP-P01X-A1	1
J891	6510007900	TBP-P01X-A1	1
J991	6510009870	PD054-02M	1
P251	6510018990	PHR-4	1
P681	6510003240	TMP-P01X-A1	1
P891	6510003240	TMP-P01X-A1	1
P991	6510018980	PHR-2	1
W251	9021770080	51/99/210/B11A/D33A	1
W252	9011130780	Wire 00 A	1
W253	9021770080	51/99/210/B11A/D33A	1
W254	9011130780	Wire 00 A	1
W294	9034704001	72/98/005/X98/X98	1
W681	9086700060	62/99/110/C31/C24	1
W682	9086700300	Wire 08	1
W891	9012962951	62/99/180/C24/C31	1
W892	9086700300	Wire 08	1
W991	9016910300	51/99/130/B11A/D33A	1
W992	9011130780	Wire 00 A	1
MP1	8510012260	2177 PLL S-CASE	1
MP2	8510010850	1897 D/A CASE	1
MP5	8510005150	602 Shield case	1
MP6	8510012140	2177 SHIELD COVER	1
MP7	8510005150	602 Shield case	1
MP8	8510012140	2177 SHIELD COVER	1
MP9	8510005150	602 Shield case	1
MP10	8510012140	2177 SHIELD COVER	1
MP11	8510012400	2177 D/A CASE	1
MP12	8510011981	2177 VCO CASE-1	1
MP13	8510011991	2177 VCO COVER-1	1

\*: Refer to SECTION 8 "BOARD LAYOUTS."

†: Optional product

**[PLL UNIT]**

REF NO.	ORDER NO.	DESCRIPTION	QTY.
MP14	8810009001	0 tap screw PH M2.6X5 ZK3	4
MP15	8510011970	2177 OSC CASE	1
MP16	8930001170	earth spring (A) (FX-294)	1
MP18	8510011250	1897 MAIN S-PLATE	1
MP19	8510011960	2177 OSC COVER	1
MP20	8930049151	2177 PLL SPRING-1	1
MP21	8930048610	2197 A-SPONGE	1
MP23	8930030220	rubber sheet (L)	1
MP24	8930049461	2177 VCO ANGLE-1	1
MP25	8930024170	earth spring (G)	1
MP26	8930049470	rubber sheet (AS)	1
MP27	8930049470	rubber sheet (AS)	1
MP28	8930036870	sponge (DZ)	1
MP29	8930049670	2177 PLL PLATE	1
MP30	8930017200	752 earth spring	1
MP33	8930017200	752 earth spring	1
MP34	8930045920	2056 SPONGE	1
MP35	8930036860	Insulation sheet (DT)	1

**[PA UNIT]**

REF NO.	ORDER NO.	DESCRIPTION	QTY.
MP36	8930055981	Shield sponge (F)-1	1
MP37	8930053900	Insulation sheet (GK)	1
MP38	8930052330	sponge (GN)	1
MP39	6910008240	59TN4772	1
RL591	6330001550	JV-12-KT	1
CP573*	6910009670	HK3-S-T	1
CP574*	6910009670	HK3-S-T	1
J101	6510007900	TBP-P01X-A1	1
J160	6510021531	IMSA-9230B-1-04Z024-PT1	1
J161	6510021531	IMSA-9230B-1-04Z024-PT1	1
J172	6510007020	TMP-J01X-V6	1
J180	6510021500	SIN-41T-2.4S	2
J181	6510021500	SIN-41T-2.4S	2
J210	6510021531	IMSA-9230B-1-04Z024-PT1	1
J211	6510021531	IMSA-9230B-1-04Z024-PT1	1
J270	6510017150	TMP-S01X-C1	1
J481	6510007900	TBP-P01X-A1	1
J571*	6510018961	B2B-PH-SM4-TB (LF) (SN)	1
J601	6510021500	SIN-41T-2.4S	1
J602	6510021500	SIN-41T-2.4S	1
J603	6510021500	SIN-41T-2.4S	1
J604	6510021500	SIN-41T-2.4S	1
J611	6510009890	PD054-04M	1
J612	6510001920	1490R	1
J621	6510019981	52808-1671	1
J641	6450000140	HSJ0807-01-010	1
J651	6510009870	PD054-02M	1
J661*	6510020081	52808-2071	1
P101	6510003240	TMP-P01X-A1	1
P481	6510003240	TMP-P01X-A1	1
P601	5610000360	LLR-06V	1
P651	6510019170	51005-0200	1
F591	5210000131	FGB 4A PBF	1
F592	5220000230	S-N5054 #01	1
F593	5220000230	S-N5054 #01	1
W101	9009130046	62/99/160/C24/C31	1
W102	9086700300	Wire 08	1
W171	9024801017	23/06/060/C21/C21	1
W180	9021770030	11/02/100/X99/X99	1
W181	9021770030	11/02/100/X99/X99	1
W361	9056200020	73/98/012/X98/X98	1
W481	9014130390	62/99/290/C24/C31	1
W482	9086700300	Wire 08	1
W601	9021770010	11/00/100/B03/X99	1
W602	9021770010	11/00/100/B03/X99	1
W603	9021770020	11/02/100/B03/X99	1
W604	9021770020	11/02/100/B03/X99	1
W605	9009630450	13/05/050/B03/B03	1
W610	9021770040	14/01/150/A08/D33	1
W611	9021770050	14/02/150/A08/D33	1
W612	9021770060	14/03/150/A08/D33	1
W613	9021770070	14/04/150/A08/D33	1
W651	9021770120	51/99/230/A15A/D33A	1
W652	9011130780	Wire 00 A	1
EP101	9068000100	Tube D=5.0 L=10MM	1
EP121	9040901901	IRRAX D=0.7 L=12MM	1
EP174	9018970370	Tube D=20.0 L=25MM	1
EP601	6910000640	FSOH090RN	1
EP602	6910000640	FSOH090RN	1
EP603	9010000660	Tube D=16.0	1
EP604	6910000630	FSOH070RN	1
EP605	6910000640	FSOH090RN	1
EP606	9010000630	Tube D=10.0	1
EP607	9010001410	Tube D=8.0	1
EP608	6910000640	FSOH090RN	1

**Screw abbreviations**

A, B0, BT: Self-tapping PH: Pan head ZK: Black  
 NI-ZU: Nickel-Zinc SUS: Stainless



**[PA UNIT]**

REF NO.	ORDER NO.	DESCRIPTION	QTY.
EP609	6910000640	FSOH090RN	1
EP610	6910000640	FSOH090RN	1
EP611	6910000640	FSOH090RN	1
EP612	9010000630	Tube D=10.0	1
MP101	8930014140	earth spring (D)	1
MP231	8860001130	2177 RUG	1
MP232	8930049100	2177 PA SPRING	1
MP233	8930014140	earth spring (D)	1
MP234	8860001130	2177 RUG	1
MP235	8930053490	Insulation sheet (GH)	1
MP241	8930050261	2177 THERMALLY SHEET-1	1
MP451	8510012150	2177 PA S-PLATE	1
MP501	8930024170	earth spring (G)	1
MP502	8930024170	earth spring (G)	1
MP601	8950000180	Cable tie -80	1
MP602	8950000180	Cable tie -80	1
MP603	8510014090	2177 DRIVER SHIELD	1
MP604	8510014110	2177 PA SHIELD	1
MP605	8950000180	Cable tie -80	1
MP606	8950000180	Cable tie -80	1
MP607	8930014140	earth spring (D)	1
MP608	8930027810	emboss tape (B)	1
MP610	8930049110	sponge (GC)	1
MP611	8930030380	FERRITE SHEET (C)	1
MP612	8930024170	earth spring (G)	1
MP613	8950000180	Cable tie -80	1

**[FILTER BOARD]**

REF NO.	ORDER NO.	DESCRIPTION	QTY.
J1	6510007900	TBP-P01X-A1	1
J2	6510007900	TBP-P01X-A1	1
J4	6450001491	HLJ7001-016010	1
J5	6510024661	TCS5072-1041577	1
J7	6450001650	HSJ0836-01-500	1
J8	6450001660	EX345GLB	1
J9*	6510020081	52808-2071	1
J11	6510016171	52018-8836	1
J12*	6510020081	52808-2071	1
J13	6510017150	TMP-S01X-C1	1
J14	6450001841	TCS7568-4320177	1
P1	6510003240	TMP-P01X-A1	1
P2	6510003240	TMP-P01X-A1	1
W11	9012962951	62/99/180/C24/C31	1
W12	9086700300	Wire 08	1
W21	9086700060	62/99/110/C31/C24	1
W22	9086700300	Wire 08	1
MP1	8930017200	752 earth spring	1
MP3	8930001170	earth spring (A) (FX-294)	1
MP4	8930055970	2177 GND SPRING	1
MP5	8930055970	2177 GND SPRING	1
MP6	8930055970	2177 GND SPRING	1

**[ACCESSORIES]**

REF NO.	ORDER NO.	DESCRIPTION	QTY.
P1	5610000410	AP-319	1
P2	5610000420	AP-338	1
MC1†	-	HM-103-1	1
F1	5210000090	FGB 30A	2
F2	5210000131	FGB 4A PBF	1
W1	8900006490	OPC-025D	1
W2	8900006110	OPC-596	1
EP1	0880000230	OPC-639 (EX-1874 PACKING)	1
EP2	6910011960	ZCAT1518-0730	1
MP1	8930007300	MIC hunger	1

\*: Refer to SECTION 8 "BOARD LAYOUTS."

†: Optional product

**Screw abbreviations**

A, B0, BT: Self-tapping PH: Pan head ZK: Black  
 NI-ZU: Nickel-Zinc SUS: Stainless

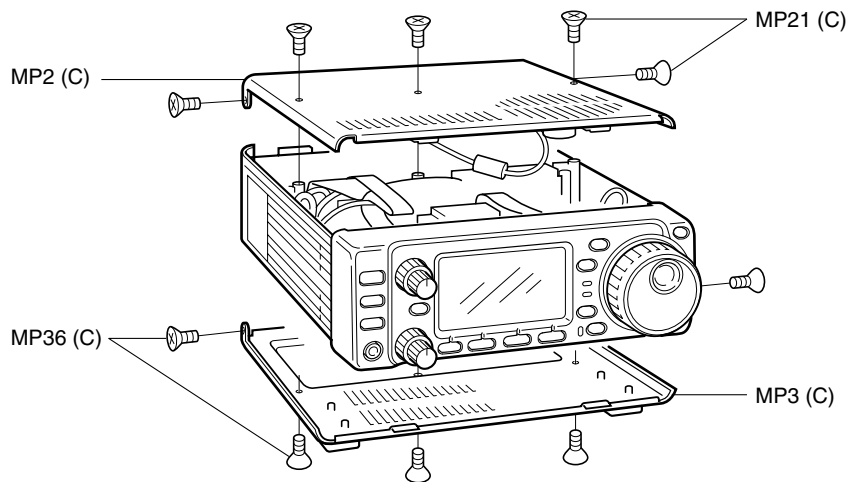
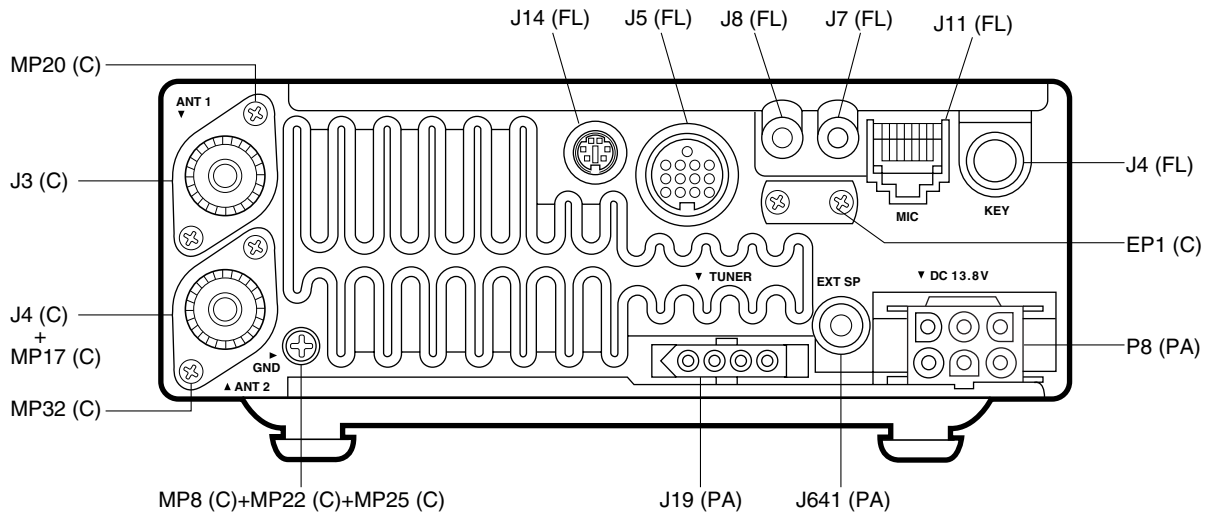
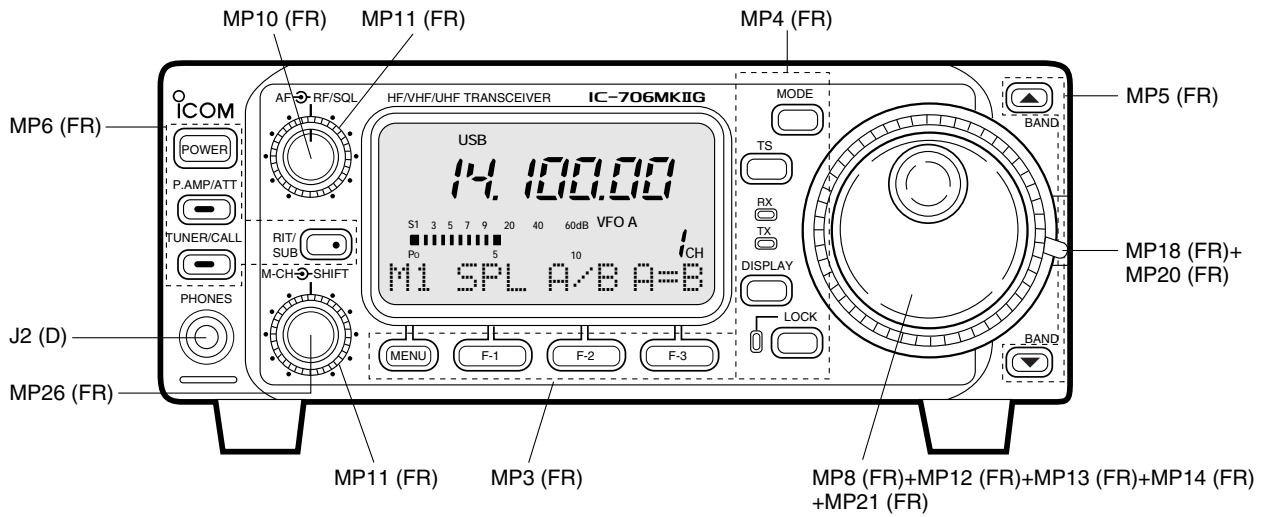



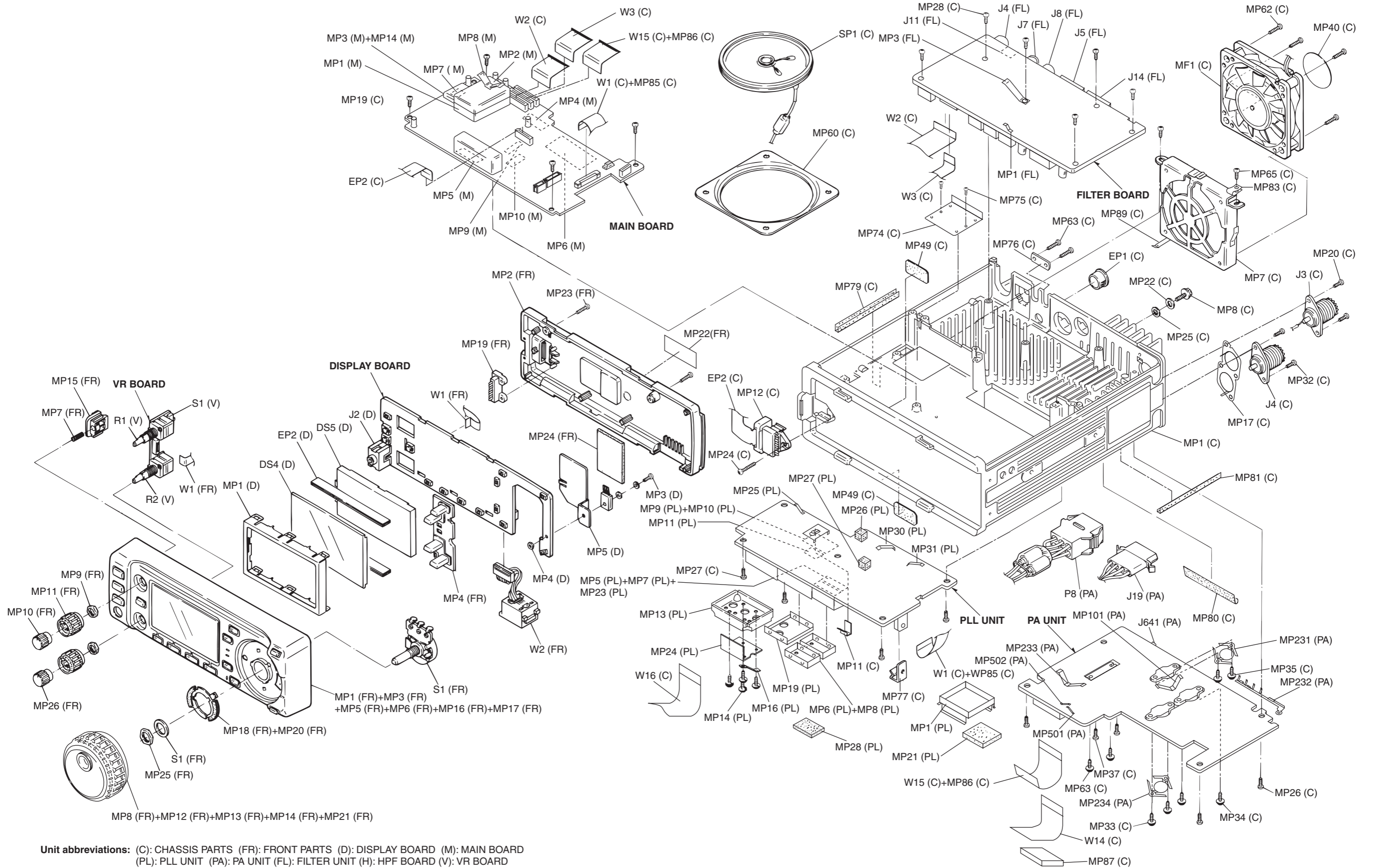

# SECTION 7 SEMICONDUCTOR INFORMATION

## • TRANSISTOR AND FET'S

<b>2SA1576 R</b> (Symbol: FR) 	<b>2SA1577 Q</b> (Symbol: FR) 	<b>2SB1123T</b> (Symbol: BF) 	<b>2SB1132R</b> (Symbol: BA) 	<b>2SB1143 S</b>  ECB
<b>2SC4081 R</b> (Symbol: BR) 	<b>2SC4116 GR</b> (Symbol: LG) 	<b>2SC4213 B</b> (Symbol: AB) 	<b>2SC4403-3</b> (Symbol: LY3) 	<b>2SC4405-3</b> (Symbol: OY3) 
<b>2SD1619</b> (Symbol: DB) 	<b>2SD1623</b> (Symbol: DF) 	<b>2SK210 GR</b> (Symbol: YG) 	<b>2SK2171-4</b> (Symbol: KM) 	<b>2SK2854</b> (Symbol: UP) 
<b>2SK508 K52</b> (Symbol: K52) 	<b>2SK880 Y</b> (Symbol: XY) 	<b>2SK882 GR</b> (Symbol: TG) 	<b>3SK126 O</b> (Symbol: UC) 	<b>3SK291</b> (Symbol: UF) 
<b>CPH3404</b> (Symbol: KD) 	<b>DTA114EE</b> (Symbol: 14) 	<b>DTA114EU</b> (Symbol: 14) 	<b>DTA144EU</b> (Symbol: 16) 	<b>DTC114EE</b> (Symbol: 24) 
<b>DTC114EU</b> (Symbol: 24) 	<b>DTC144EE</b> (Symbol: 24) 	<b>MRF1508T1</b> (Symbol: 1508) 	<b>MXR9745RT1</b> (Symbol: RG) 	<b>RN1202</b>  ECB
<b>SRFJ7044</b> (Symbol: SRFJ7044) 	<b>UMC1NTR</b> (Symbol: C1) 	<b>UMC3N TR</b> (Symbol: C3) 	<b>XP4111</b> (Symbol: 9U) 	

## • DIODES

<b>1SS302</b> (Symbol: C3) 	<b>1SS355</b> (Symbol: A) 	<b>1SS375</b> (Symbol: FH) 	<b>1SS385</b> (Symbol: 09) 	<b>1SV237</b> (Symbol: BB) 
<b>1SV265</b> (Symbol: LV) 	<b>1SV305</b> (Symbol: TV) 	<b>1SV308</b> (Symbol: TX) 	<b>1SV312</b> (Symbol: BB) 	<b>DA221</b> (Symbol: K) 
<b>DAN202U</b> (Symbol: N) 	<b>DAN222</b> (Symbol: N) 	<b>DAP202U</b> (Symbol: P) 	<b>DAP222</b> (Symbol: P) 	<b>HSB88WSTR</b> (Symbol: Silver line) 
<b>KV1470TL</b> (Symbol: F7) 	<b>MA114</b> (Symbol: 1E) 	<b>MA2S077</b> (Symbol: S) 	<b>MA2S111</b> (Symbol: A) 	<b>MA2S728</b> (Symbol: B) 
<b>MA2SV0500L</b> (Symbol: A) 	<b>MA304B</b> (Symbol: 7R) 	<b>MA357</b> (Symbol: NL) 	<b>MA717WK</b> (Symbol: M3D) 	<b>MA742</b> (Symbol: M1U) 
<b>MA77</b> (Symbol: 4B) 	<b>MA8027</b> (Symbol: 2^7) 	<b>MA8033</b> (Symbol: 3_3) 	<b>MA8036L</b> (Symbol: 3_6) 	<b>MA8056M</b> (Symbol: 5-6) 
<b>MA8068M</b> (Symbol: 6-8) 	<b>MA862</b> (Symbol: M11) 	<b>RD12M T2B2</b> (Symbol: 122) 	<b>UM9401F</b> 	







The combination of this side and the bottom side shows the board layout in the same configuration as the actual P.C.Board.

• PLL UNIT (BOTTOM VIEW)

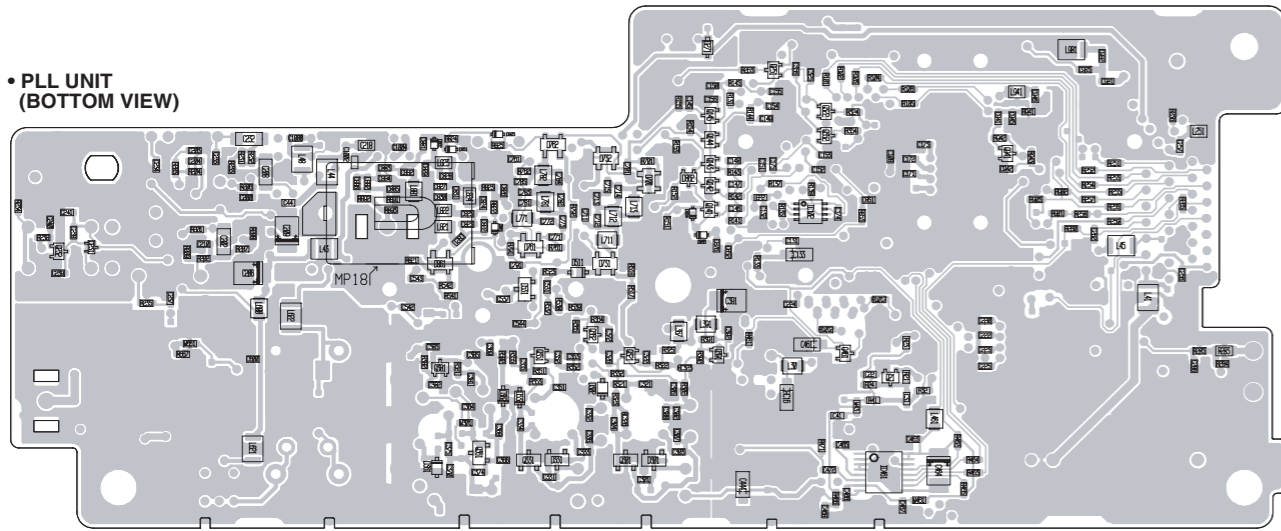

• FILTER UNIT (BOTTOM VIEW)

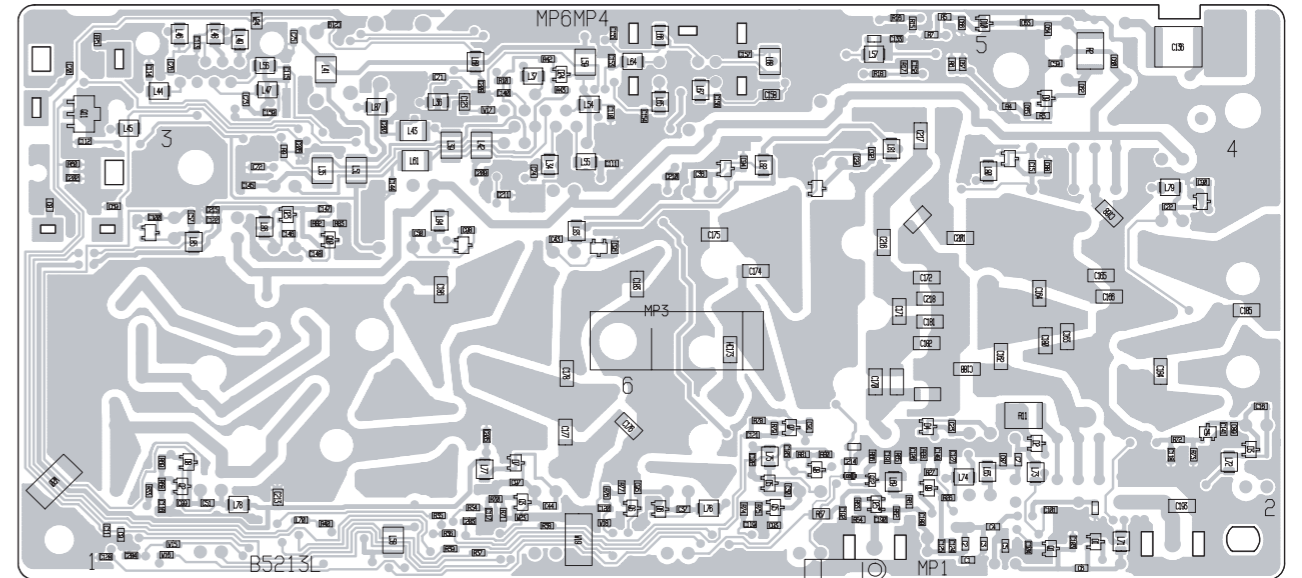

• VR UNIT (BOTTOM VIEW)



• DRIVE UNIT (BOTTOM VIEW)

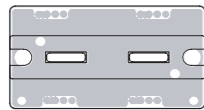

• DISPLAY UNIT (BOTTOM VIEW)

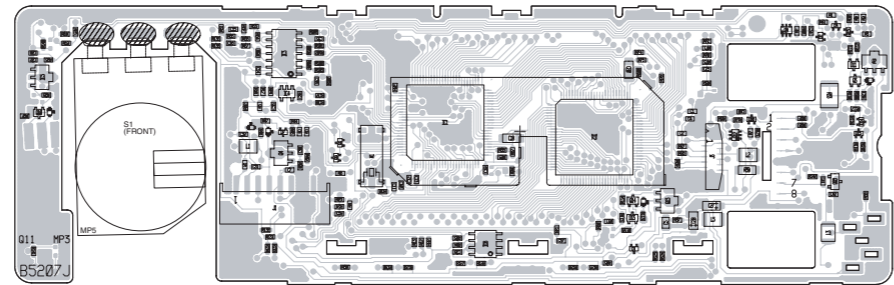

1	J3		2
	DN	AFL	
	AFL	AF	
	SOL	AF	
	AFV	AFS	
	UP	AFS	
	SFT	5V	
	GND		12
13			

TO VR BOARD J1

1	J1		8
	BVLM		
	UID		
	AF		
	PTT		
	MICEL		
	MICL		
	GND		
	SQLS		

TO FRONT UNIT W2

• HPF UNIT (BOTTOM VIEW)

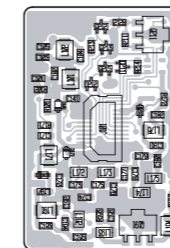

11	J101		10
	GND	SRF	
	GND	SRF	
	T8V	GND	
	B7H	PA2S	
	L5H	L6H	
	L3H	L4H	
	L2H	THH	
	GND	GND	
	SIF	GND	
	SIF	GND	
20			1

TO MAIN UNIT J1

• PA UNIT (BOTTOM VIEW)

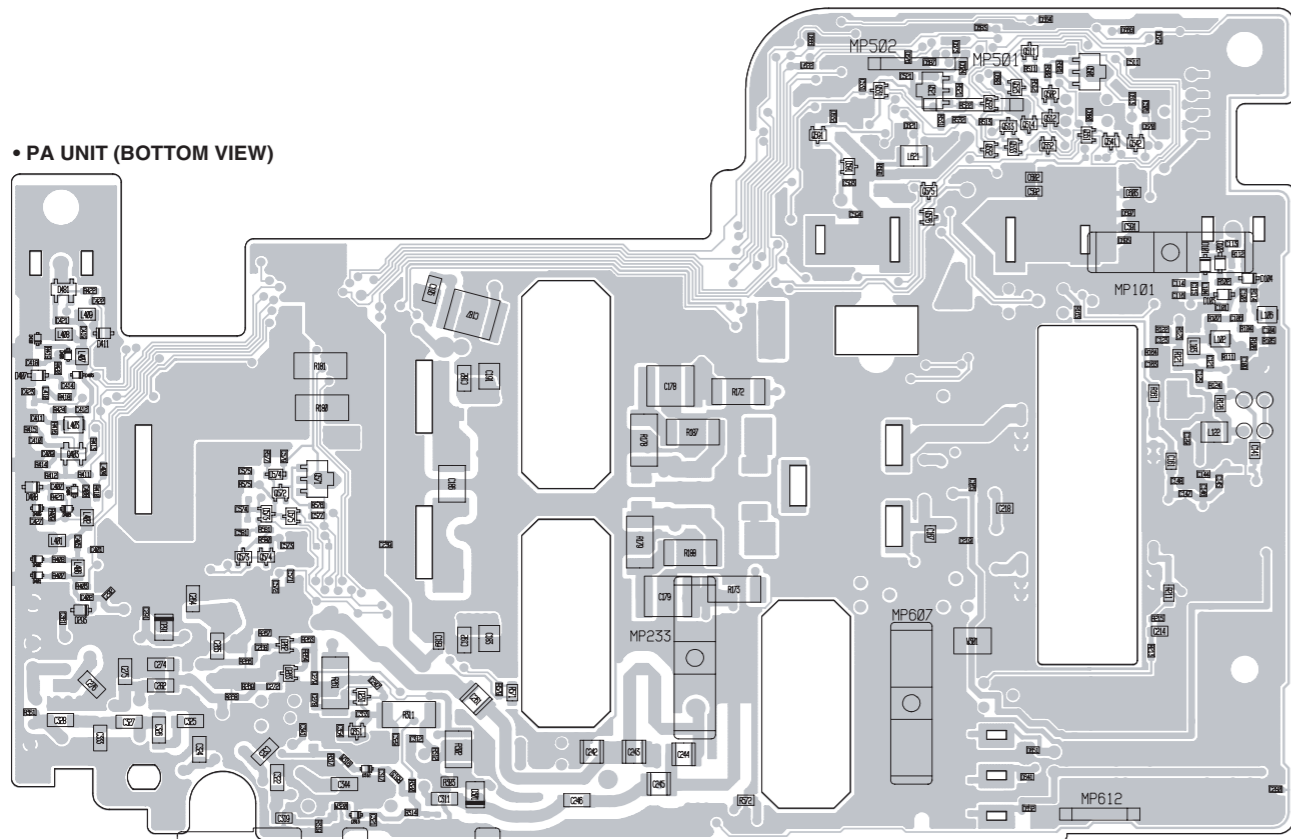

• MAIN UNIT (BOTTOM VIEW)

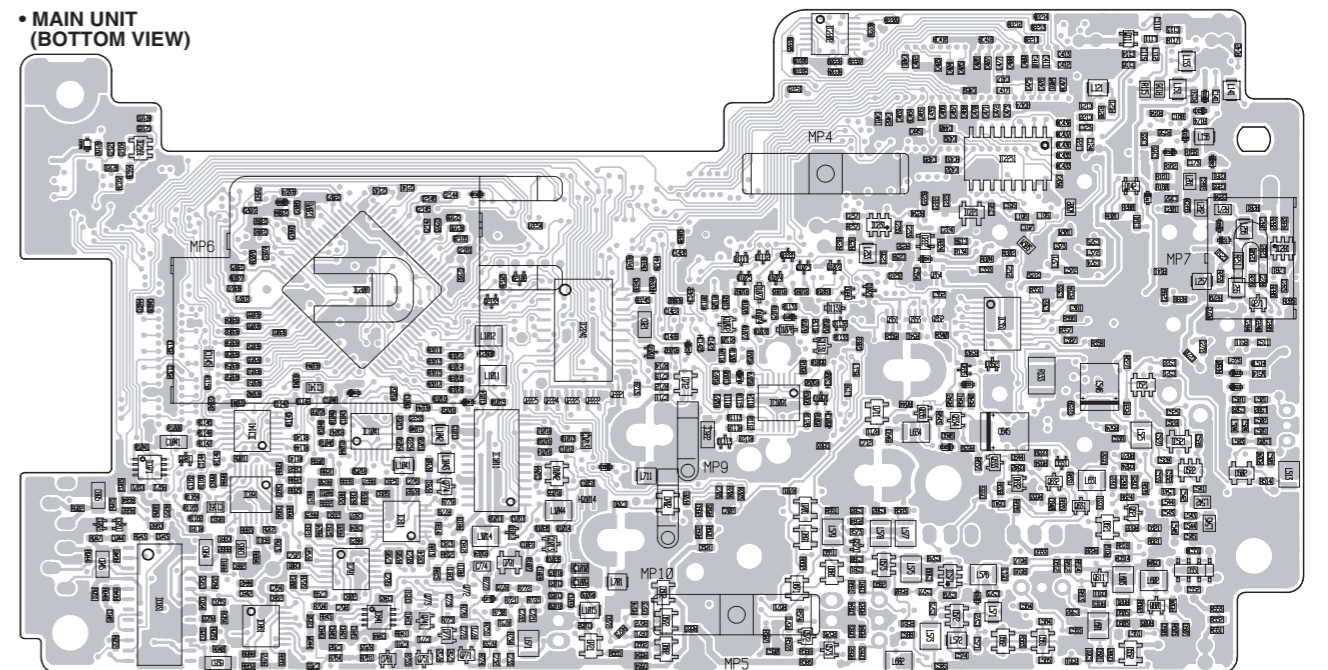

# SECTION 9

# BLOCK DIAGRAM

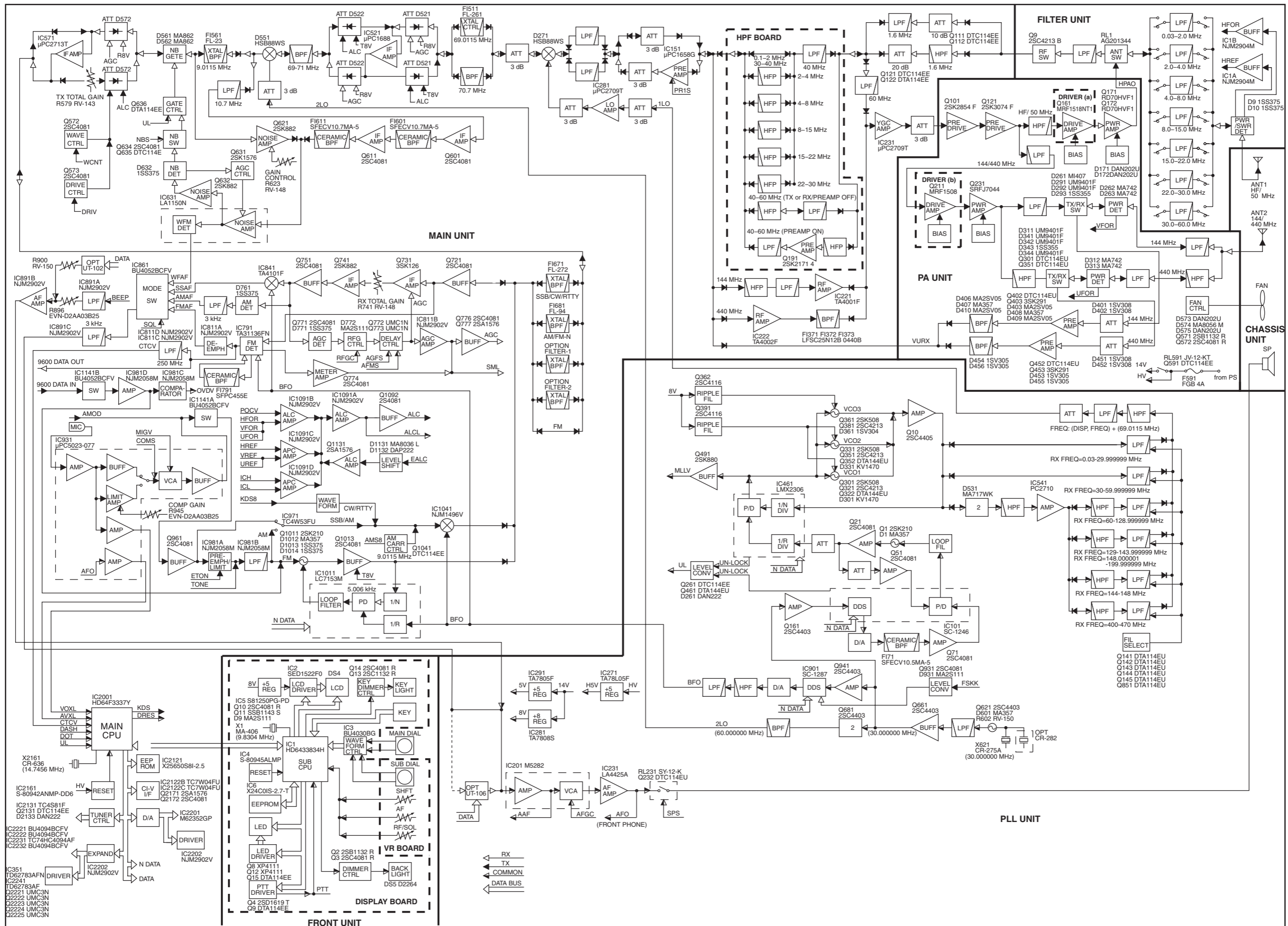





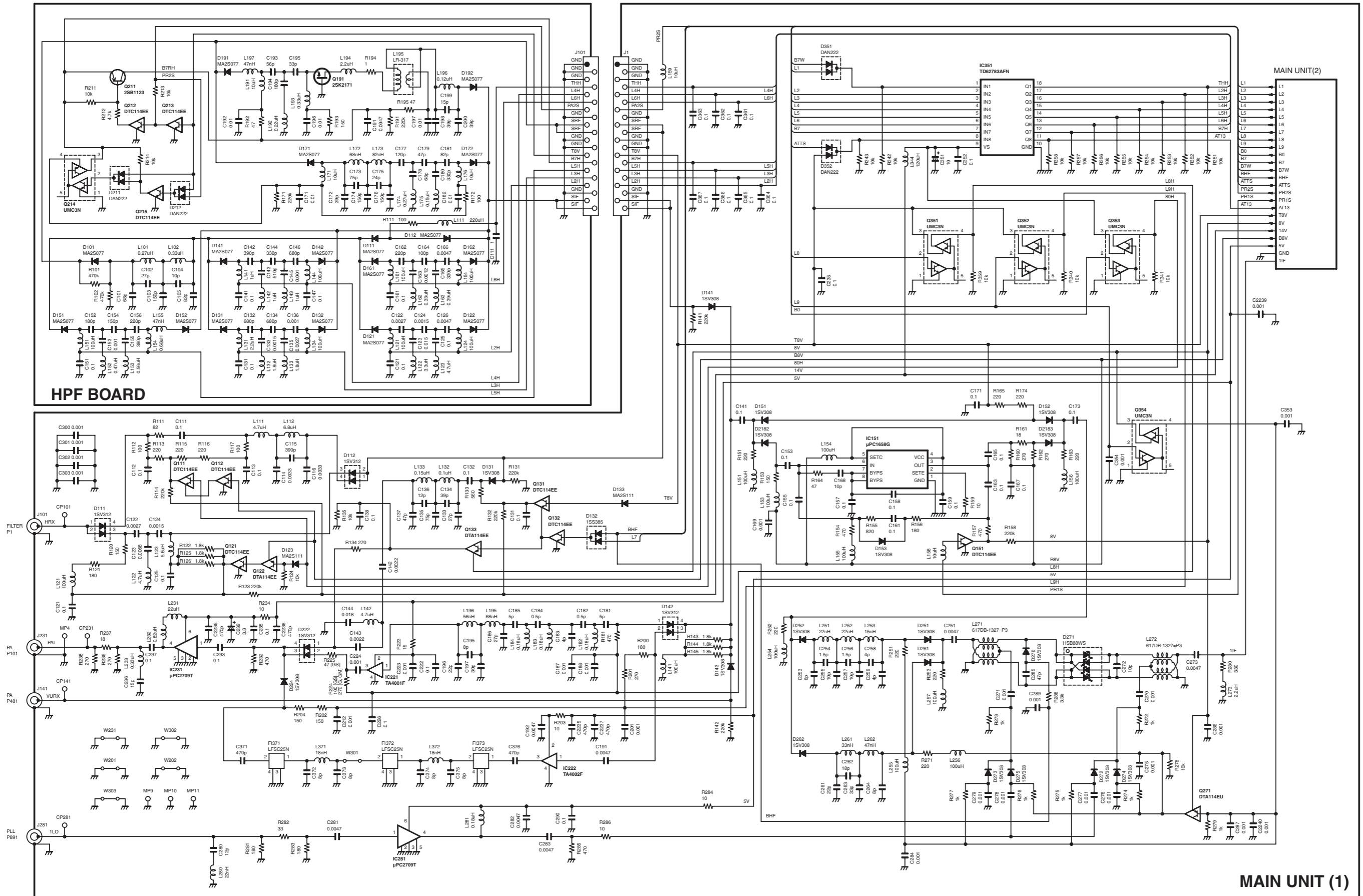

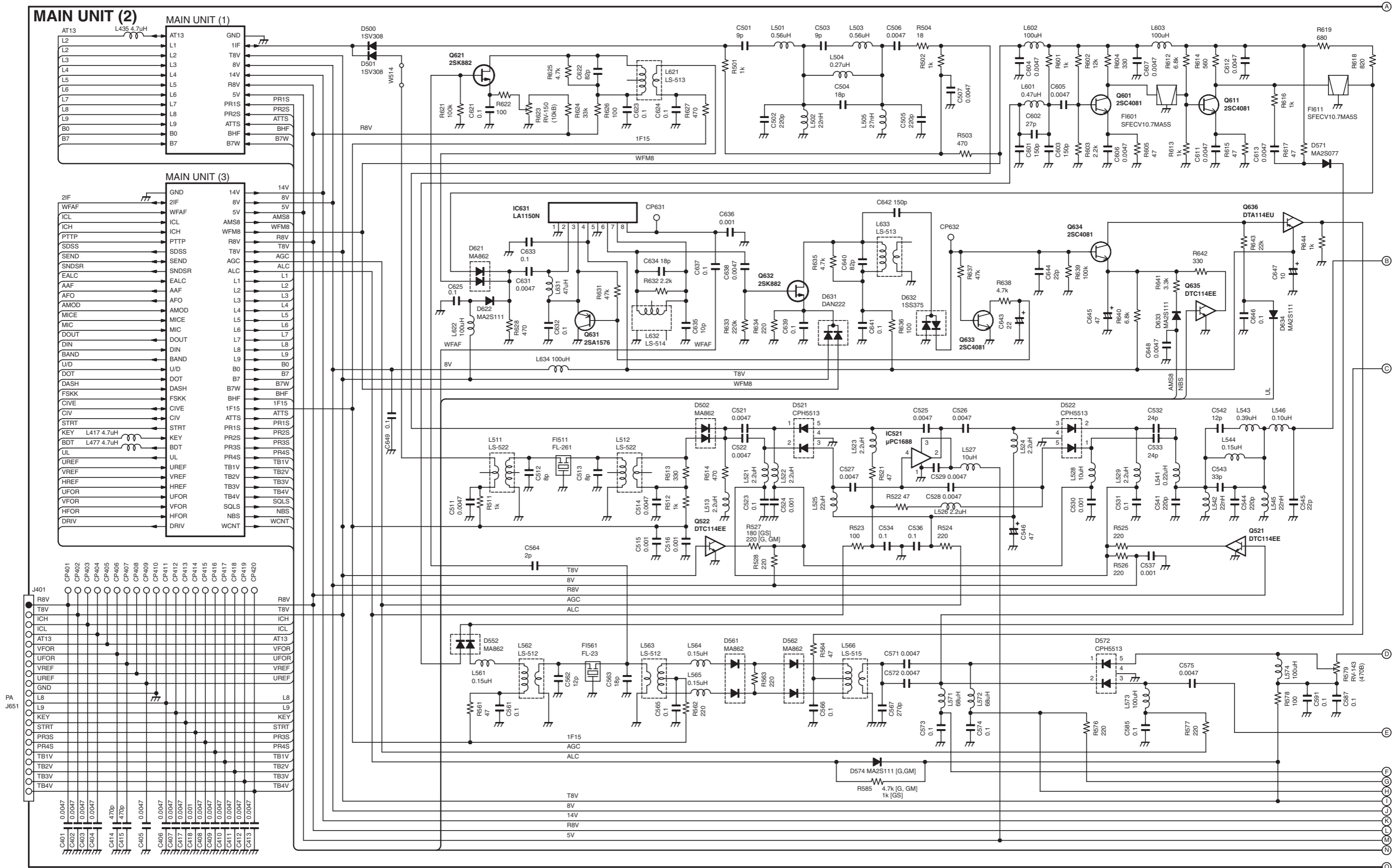

# MAIN UNIT (2)

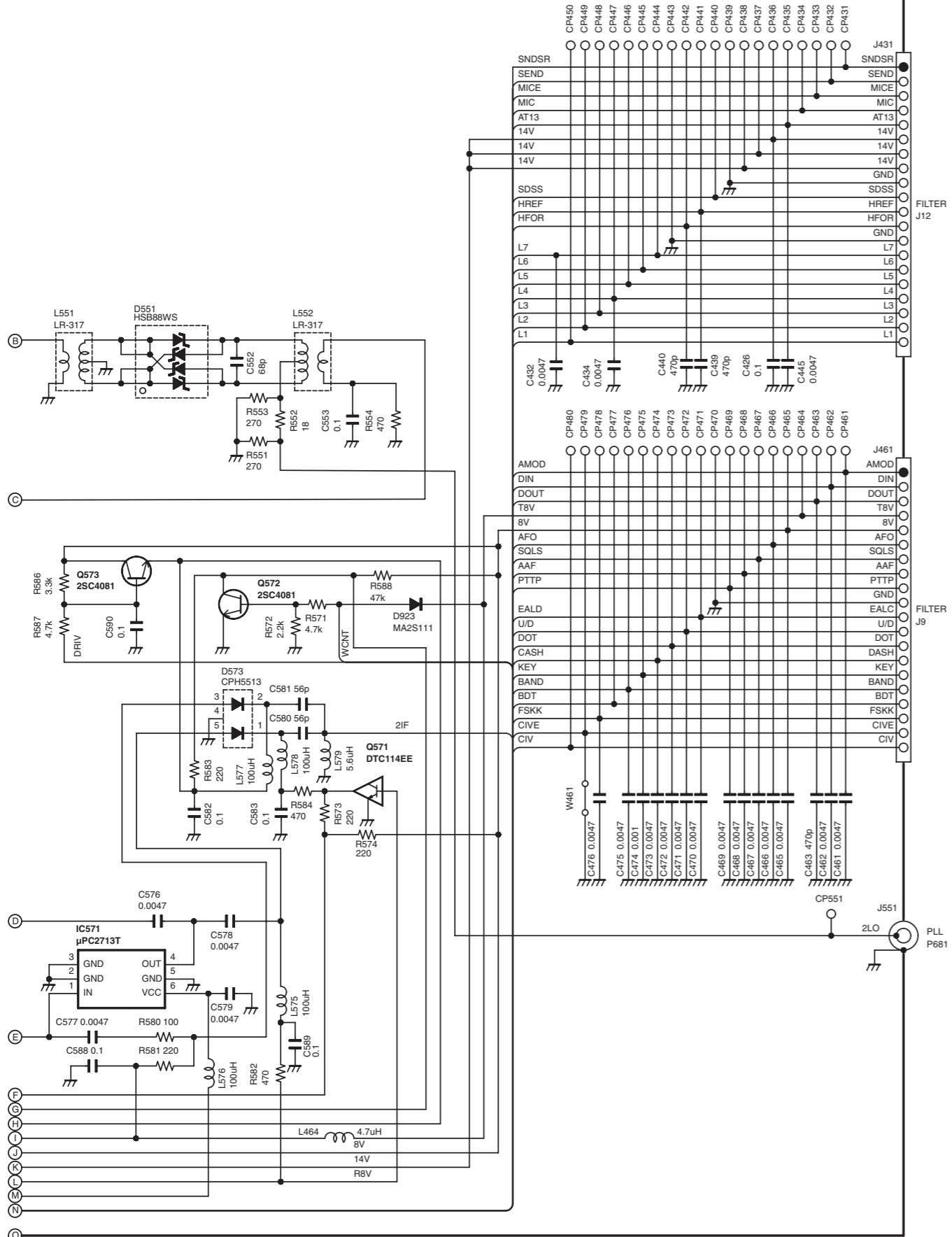

# MAIN UNIT (3)

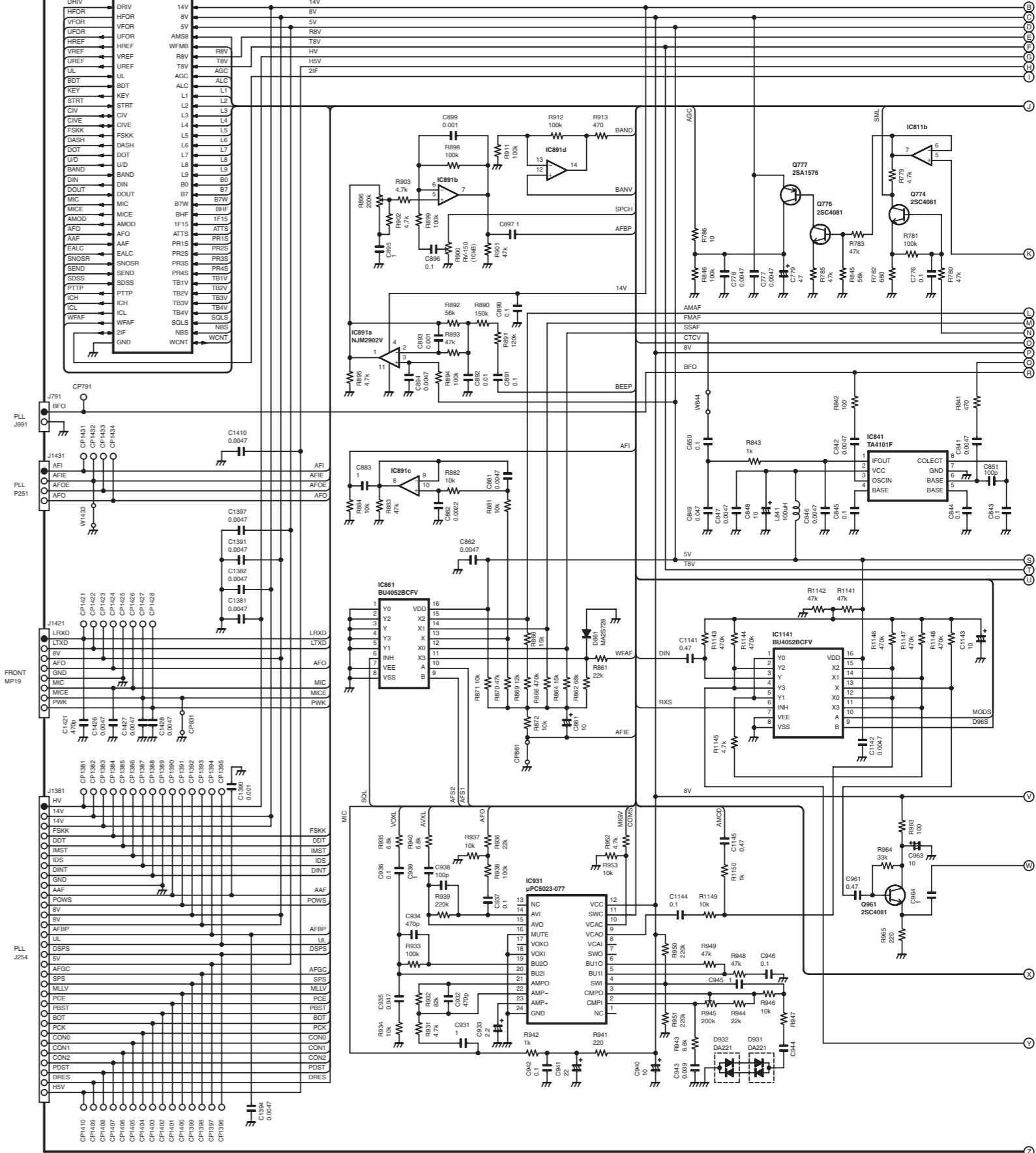



# MAIN UNIT (3)

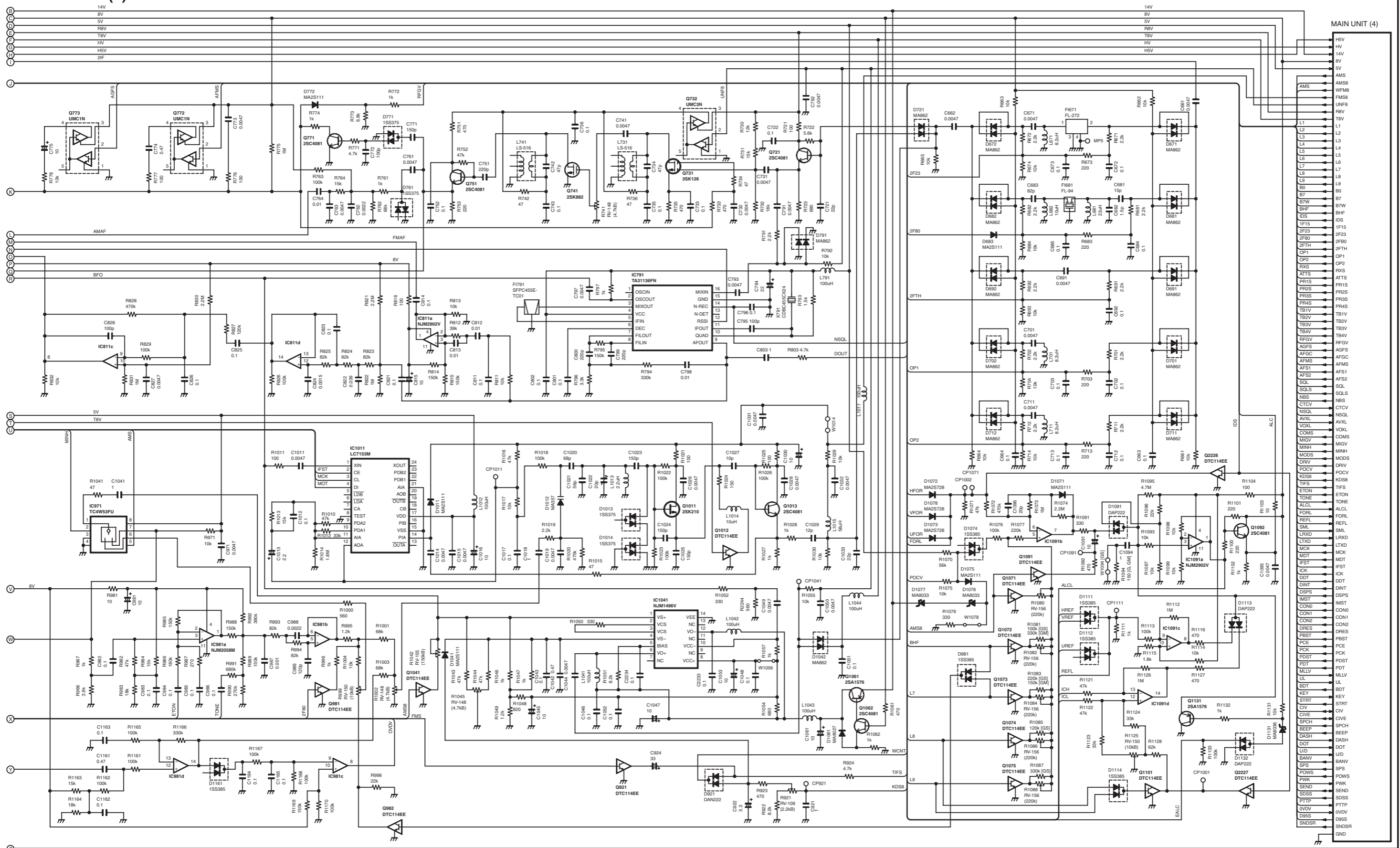

MAIN UNIT (4)

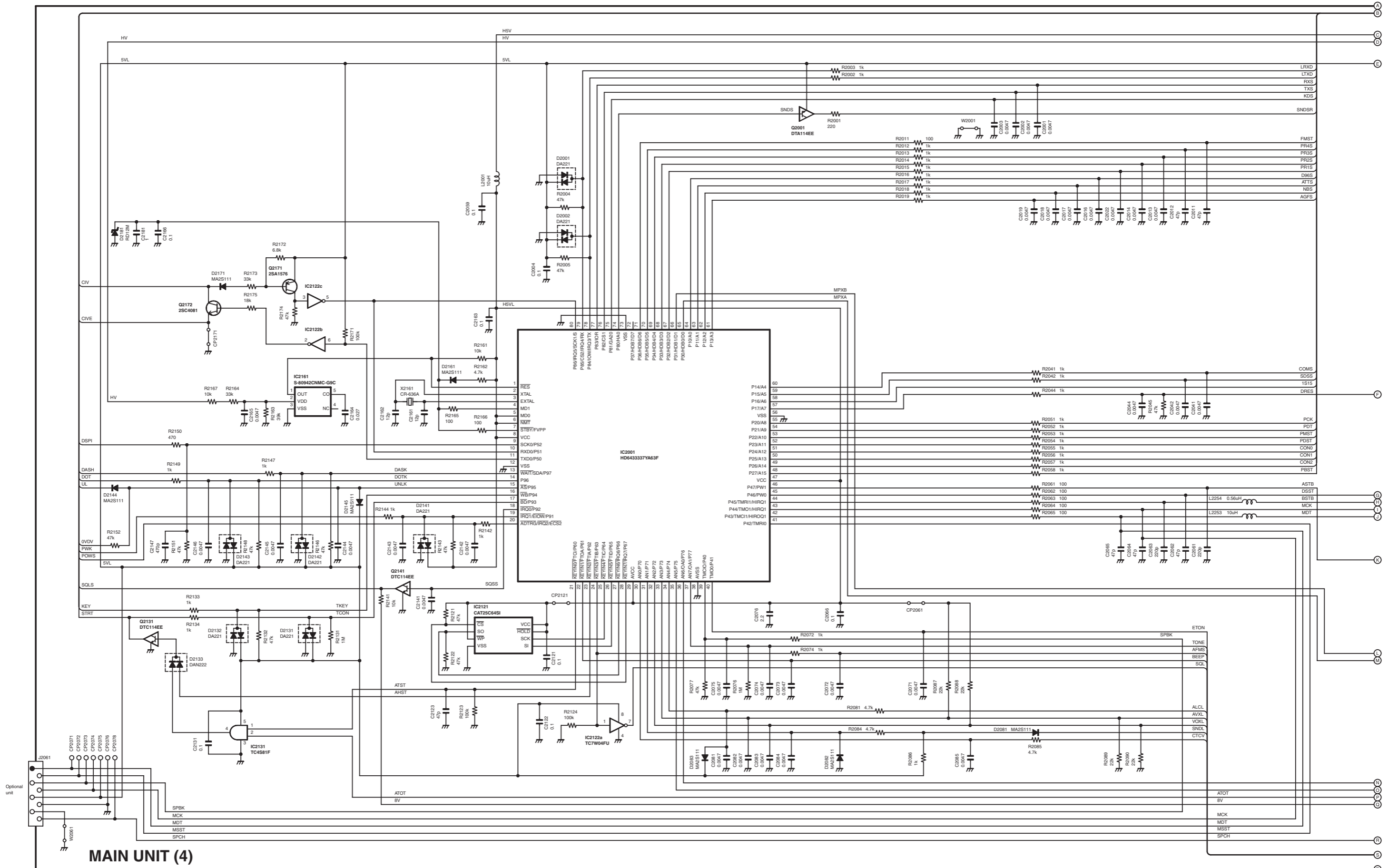

**MAIN UNIT (4)**

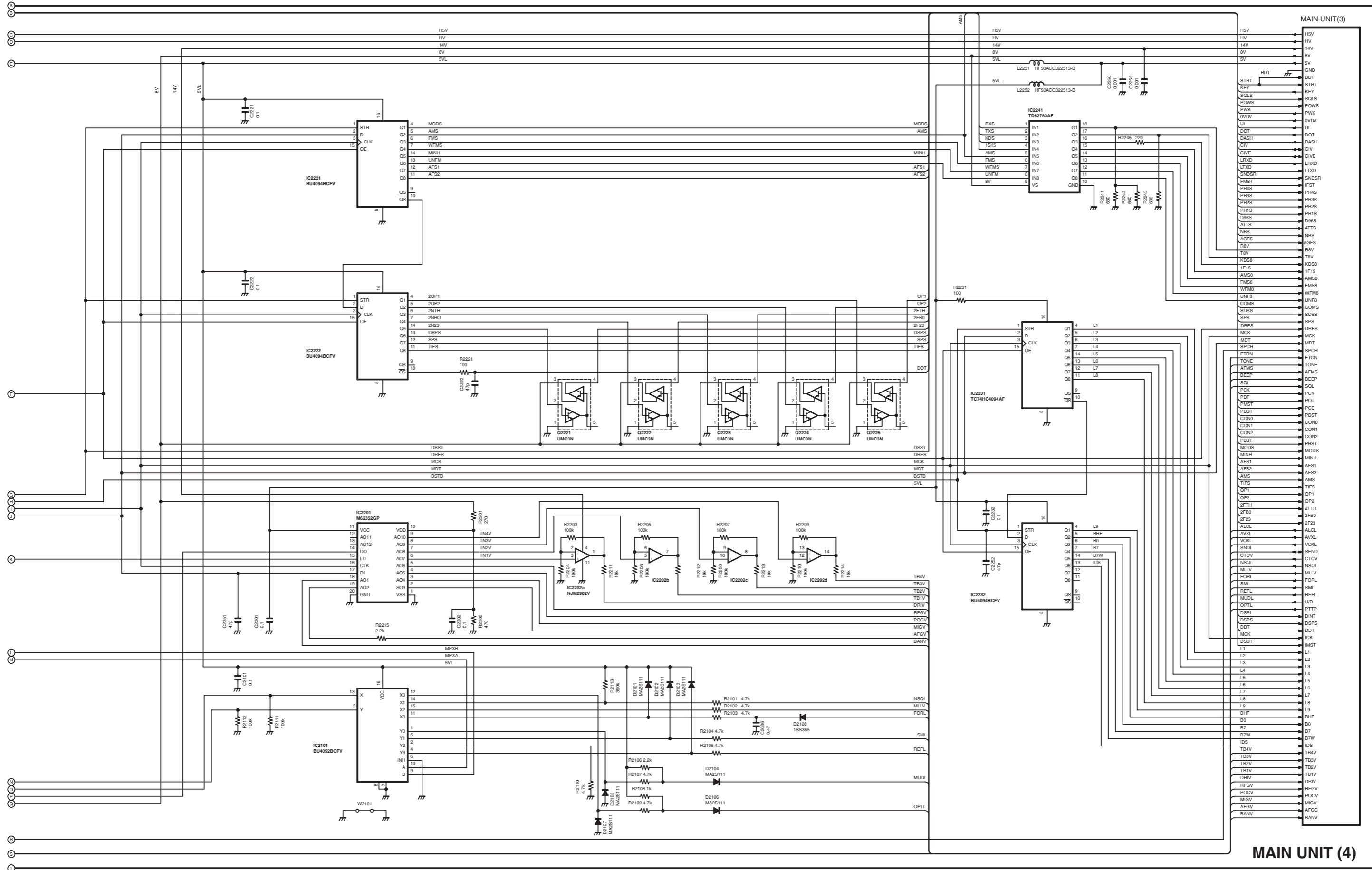





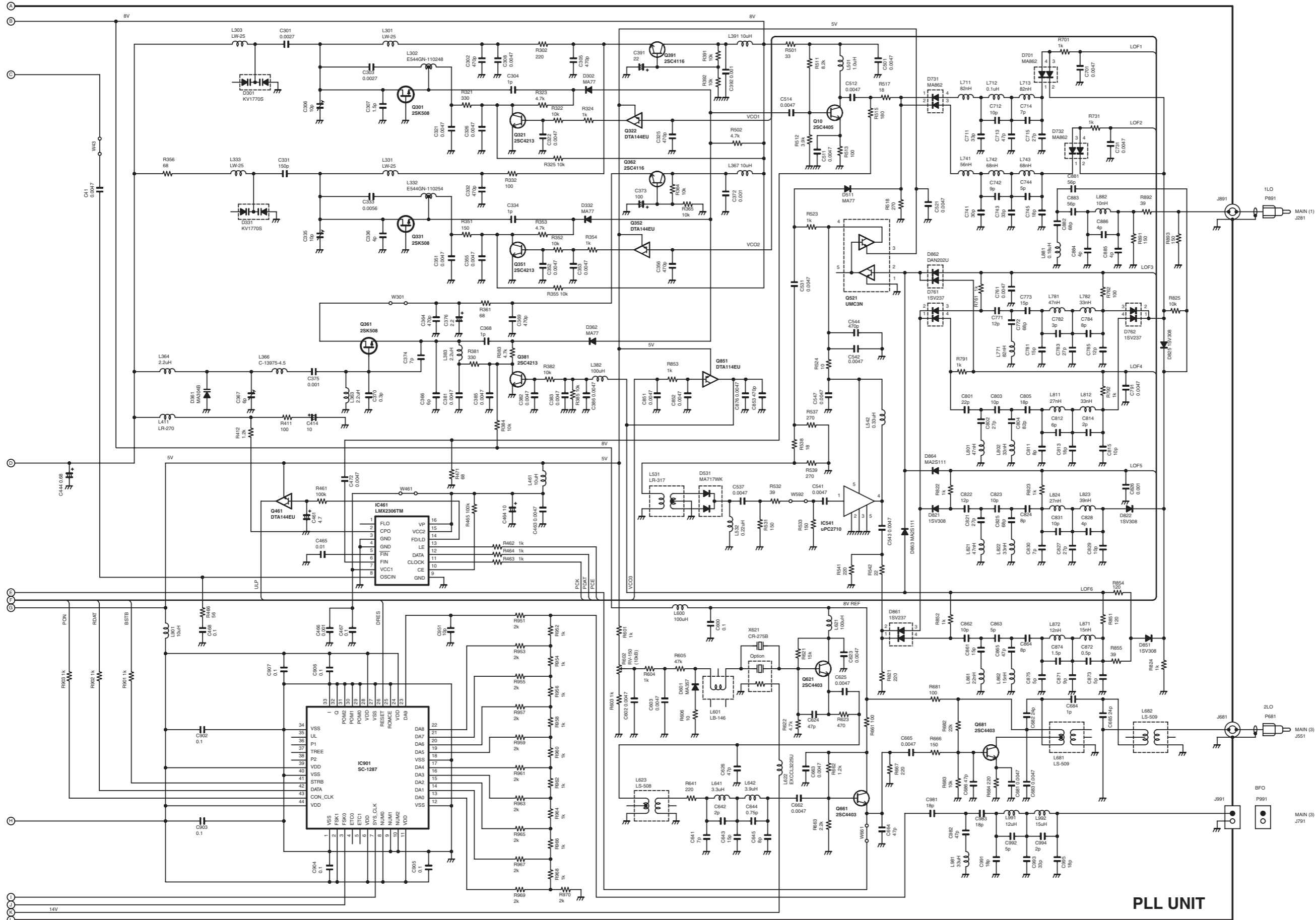

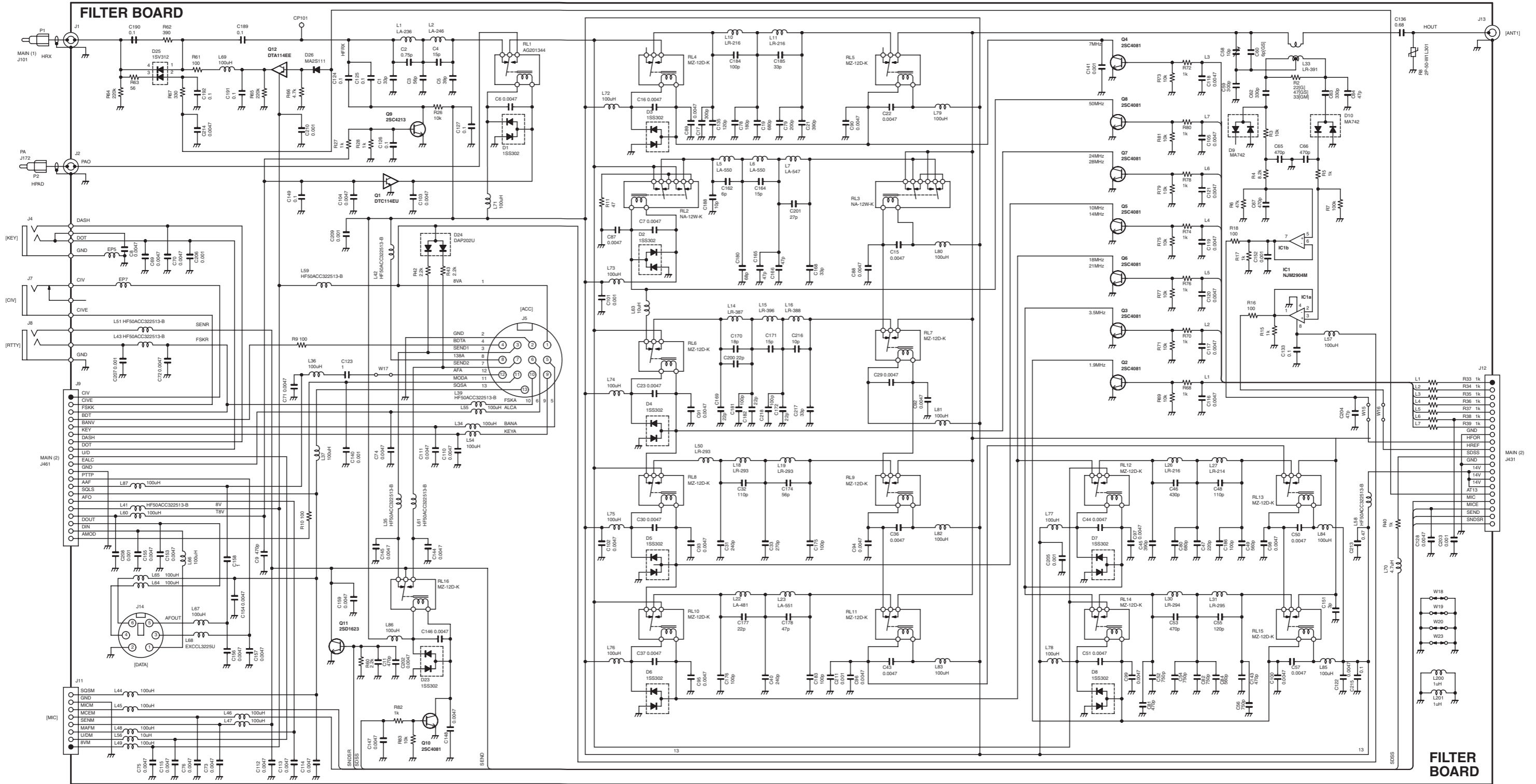

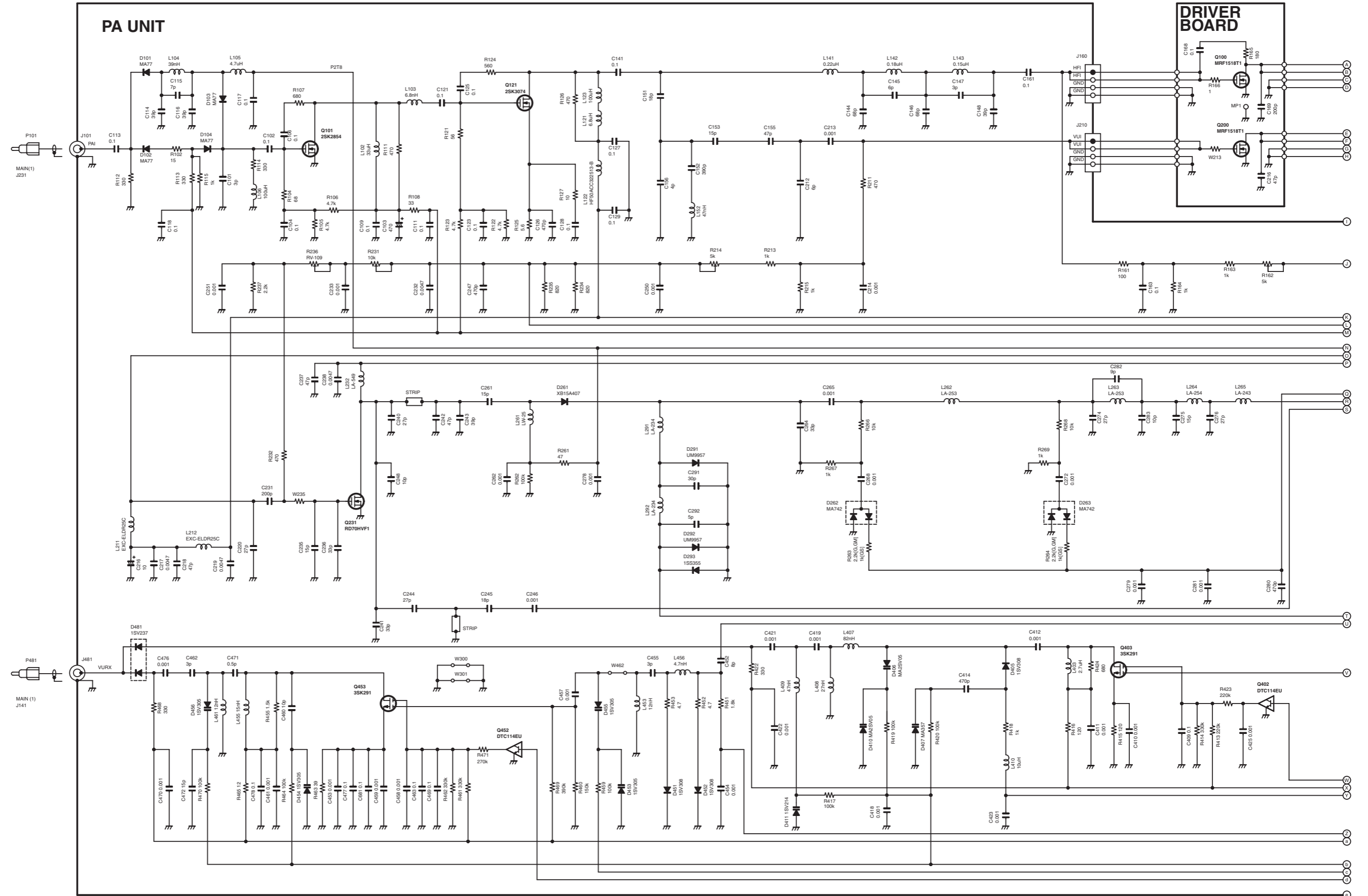





## Icom Inc.

1-1-32, Kamiminami, Hirano-ku, Osaka 547-0003, Japan  
Phone : +81 (06) 6793 5302  
Fax : +81 (06) 6793 0013  
URL : <http://www.icom.co.jp/world/index.html>

### Icom America Inc.

<Corporate Headquarters>  
2380 116th Avenue N.E., Bellevue, WA 98004, U.S.A.  
Phone : +1 (425) 454-8155 Fax : +1 (425) 454-1509  
URL : <http://www.icomamerica.com>  
E-mail : [sales@icomamerica.com](mailto:sales@icomamerica.com)  
<Customer Service>  
Phone : +1 (425) 454-7619

### Icom Canada

Glenwood Centre #150-6165  
Highway 17 Delta, B.C., V4K 5B8, Canada  
Phone : +1 (604) 952-4266 Fax : +1 (604) 952-0090  
URL : <http://www.icomcanada.com>  
E-mail : [info@icomcanada.com](mailto:info@icomcanada.com)

### Icom (Australia) Pty, Ltd.

Unit 1 / 103 Garden Road, Clayton VIC 3168 Australia  
Phone : +61 (03) 9549-7500 Fax : +61 (03) 9549-7505  
URL : <http://www.icom.net.au>  
E-mail : [sales@icom.net.au](mailto:sales@icom.net.au)

### Icom New Zealand

146A Harris Road, East Tamaki,  
Auckland, New Zealand  
Phone : +64 (09) 274 4062 Fax : +64 (09) 274 4708  
URL : <http://www.icom.co.nz>  
E-mail : [inquiries@icom.co.nz](mailto:inquiries@icom.co.nz)

### Beijing Icom Ltd.

10C07, Long silver Mansion, No.88, Yong Ding  
Road, Haidian District, Beijing, 100039, China  
Phone : +86 (010) 5889 5391/5392/5393  
Fax : +86 (010) 5889 5395  
E-mail : [bjicom@bjicom.com](mailto:bjicom@bjicom.com)  
URL : <http://www.bjicom.com>

### Icom (Europe) GmbH

Communication Equipment  
Himmelgeister Str. 100, D-40225 Düsseldorf, Germany  
Phone : +49 (0211) 346047 Fax : +49 (0211) 333639  
URL : <http://www.icomeurope.com>  
E-mail : [info@icomeurope.com](mailto:info@icomeurope.com)

### Icom Spain S.L

Ctra. Rubi, 88, 08190, Sant Cugat del Valles, Barcelona, SPAIN  
Phone : +34 (93) 590 26 70 Fax : +34 (93) 589 04 46  
URL : <http://www.icomspain.com>  
E-mail : [icom@icomspain.com](mailto:icom@icomspain.com)

### Icom (UK) Ltd.

Unit 9, Sea St., Herne Bay, Kent, CT6 8LD, U.K.  
Phone : +44 (01227) 741741 Fax : +44 (01227) 741742  
URL : <http://www.icomuk.co.uk>  
E-mail : [info@icomuk.co.uk](mailto:info@icomuk.co.uk)

### Icom France s.a.s.

Zac de la Plaine  
1 Rue Brindejonc des Moulinais BP 5804  
31505 Toulouse Cedex, France  
Phone : +33 (5) 61 36 03 03 Fax : +33 (5) 61 36 03 00  
URL : <http://www.icom-france.com>  
E-mail : [icom@icom-france.com](mailto:icom@icom-france.com)

### Asia Icom Inc.

6F No.68, Sec. 1 Cheng-Teh Road, Taipei, Taiwan, R.O.C.  
Phone : +886 (02) 2559 1899 Fax : +886 (02) 2559 1874  
URL : <http://www.asia-icom.com>  
E-mail : [sales@asia-icom.com](mailto:sales@asia-icom.com)

### Icom Polska

Sopot, 3 Maja 54 Poland  
Phone : +48 (58) 550 7135 Fax : +48 (58) 551 0484  
E-mail : [icompolska@icompolska.com.pl](mailto:icompolska@icompolska.com.pl)

**Count on us!**

**Icom Inc.**

1-1-32, Kamiminami, Hirano-ku, Osaka 547-0003, Japan

S-14411XZ-C1  
© 2007 Icom Inc.